

Measurement of CNGS Muon Neutrinos Speed with Borexino: INRIM and ROA Contribution

Giancarlo Cerretto¹, Hector Esteban², Marco Pallavicini³, Valerio Pettiti¹, Cedric Plantard¹, and Alessandro Razeto⁴

¹Optics Division, INRIM (Istituto Nazionale di Ricerca Metrologica), Torino, Italy

²Time Department, ROA (Real Instituto y Observatorio de la Armada), San Fernando, Spain

³Dipartimento di Fisica, Università e INFN, Genova, Italy

⁴Laboratori Nazionali del Gran Sasso, INFN, Assergi, Italy

g.cerretto@inrim.it

Abstract—This paper describes the contribution given by the INRIM “Time and Frequency Laboratory” and the ROA “Time Department” to the Borexino cooperation in the experiments for the accurate measurement of the CNGS (CERN neutrinos to Gran Sasso) muon neutrinos speed. We briefly report about the design, installation, and performance of a new system called High Precision Timing Facility (HPTF), intended as a GPS-based timing facility with a calibrated time-link to the CERN GPS receiver and with continual real time monitoring of the fiber link time delay to the underground laboratory. Details about the INRIM/ROA contribution will be presented, reporting the calibration of the CERN-LNGS GPS time link, as well as the calibration of the HPTF internal delays. This system, specifically designed for the Borexino experiments, has also been made available to other LNGS experiments (namely, LVD and Icarus) and has been used to measure the muon neutrino speed in May 2012, during a special short bunch run of the CNGS beam.

I. THE BOREXINO DETECTOR

In Figure 1, the schematic drawing of the Borexino detector inside an even more schematic Hall C at Laboratori Nazionali del Gran Sasso (LNGS) is shown. Most of the CNGS events are muons produced by neutrinos in the rock upstream. CERN is on the left. Muons are inclined 3.2° above the horizontal axis. As far as CNGS events are concerned, Borexino is made of two independent parts: a large domed steel tank of 18 m diameter and 16.9 m height filled with 2100 t of ultra-pure water and instrumented with 208 PMTs which detect the muon Cherenkov emission; a Stainless Steel Sphere (SSS, external radius 6860 mm) filled with 1300 m³ of scintillator and buffer liquid viewed by 2212 PMTs, which detect the scintillation light emitted both by the true scintillator (yield 500 p.e./MeV) and by the buffer liquid (yield 25 p.e./MeV). The active medium for the detection of CNGS muons in the SSS is therefore the whole SSS volume. The CNGS muon neutrinos are detected in Borexino through their interaction with an atomic nucleus, which may be in the detector (internal event) or, much more frequently, in the rock upstream (external event). Neutral current interactions in the rock do not provide a visible signal in Borexino, so most of the events are quasi-horizontal muons that cross both the Water Tank and the SSS. The much less abundant internal events are detected both via charged and neutral current interactions. Muons produce a clear and fast signal in both scintillator and Cherenkov detectors. A custom module performs the logical OR of the scintillator detector and Cherenkov detector triggers, providing the CNGS Trigger signal. The purpose of the HPTF to which INRIM and ROA have contributed is to measure with high precision the time difference between the CNGS Trigger signal and the moment in which the proton beam has hit the target at CERN and the neutrinos sent to Gran Sasso are generated.

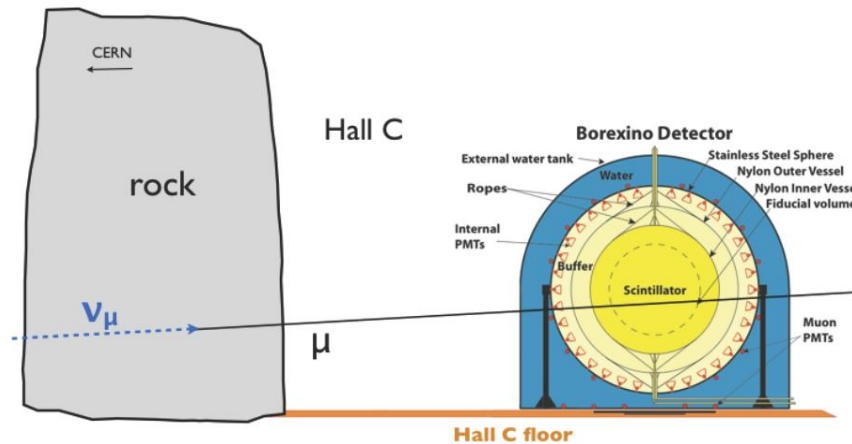

Figure 1. Schematic drawing of the Borexino detector inside an even more schematic Hall C at Laboratori Nazionali del Gran Sasso (LNGS).

II. THE HIGH PRECISION TIMING FACILITY (HPTF)

In Figure 2, the HPTF [1] system is shown. This system is designed to bring the Borexino triggers from the Hall C underground up to the core of the facility which is located outside, close to the GPS antenna, and measure with high precision the time of a given trigger. It is composed of several parts: a connection from underground to the external laboratory with real time monitoring of the propagation delay, a GPS receiver coupled to a low jitter Rubidium (Rb) clock, a set of Time Interval Counters, and high precision 1PPS/Frequency distributors.

One of the main features of this system is the ability to bring the triggering signal generated by the detector close to the GPS system via optical fibers and, even more importantly, to monitor on a real time basis the length of the link. This is done by means of the optical fiber link, which is made of two fibers: a main fiber (used to deliver the trigger), and a calibration fiber (used as well to deliver a second copy of the trigger and to bring back and forth a calibration pulse). Two copies of the CNGS Trigger signal are generated: one of them is converted into an optical signal and sent out to the external laboratory through one optical fiber; a second copy is put in logical OR with the calibration signal that comes from a second fiber (calibration fiber) and sent back to the same fiber by means of a Y-shape optical connection and an (RX) optical-to-TTL receiver and (TX) TTL-to-optical transmitter pair. In the external laboratory, the optical signal is converted back to TTL pulses by the same transceivers. The CNGS Trigger signal coming from the main fiber is split in two copies: one is used to measure the time difference between the trigger itself and the 10PPS signal coming from the GPS receiver (Local System Time, LST), while a second copy is used to measure the time difference with the other copy of CNGS Trigger that has traveled through the calibration fiber. A high stability, low jitter clock with 10 MHz frequency, is required as both a source for the GPS receiver and as a time base for the Time Interval Counters. A minimum intrinsic accuracy of 10^{-9} s/s is required, to allow 1 ns precision over 1 second. A phase noise better than 100 dBc is required as well to keep the time jitter below 1 ns. The Rubidium reference source, the FS725 from Stanford Research Systems (Rb), provides such features, providing also the feature to be locked with an external GPS receiver. In the GPS disciplined configuration, both the oscillator frequency and the phase are continually corrected with a time constant of 8 hours, providing a long term stability that is much better than the one achieved with the Rb clock only. The instability of the Rb clock in this configuration was measured at INRIM and is about 1.0×10^{-11} s/s ($\tau = 1$ s).

In HPTF several logic pulse distributors are needed. In order to minimize the error in the measurements and the jitters, we have used only high quality, low jitter, low temperature drift, and thermally compensated channels to distribute the critical signals. The PD5-RM-B pulse distribution amplifier, from

SpectraDynamics, provides such characteristics: the units are 2 independent distribution amplifiers with 5 outputs; qualification measurements, done at the INRIM facilities in Torino, show that the first 4 channels of each amplifier are aligned in time within 100 ps, while the fifth is within 200 ps; the temperature coefficient is about 3 ps/C. In the HPTF, we have used 5 TICs produced by Pendulum, 3 of model CNT-90 (resolution 100 ps) and another 2 of model CNT-91 (resolution 50 ps); among other features, these devices can be programmed to provide a relative timestamp for each measurement, which is the time of the start since the last reset, with the instrument resolution. The readout is done via USBTMC, a protocol for instrumentation over USB. A Septentrio PolaRx4TR GPS+GLONASS+GALILEO, synchronized with the Rubidium oscillator, has been used to generate the HPTF LST (with respect to which the HPTF CNGS trigger has been measured). Through this device it was possible to synchronize such a trigger signal, with the analogous signal generated at CERN and related to a Cesium reference clock. The calibration of the GPS time link between HPTF and CERN was one of the most important measurements to be carried out.

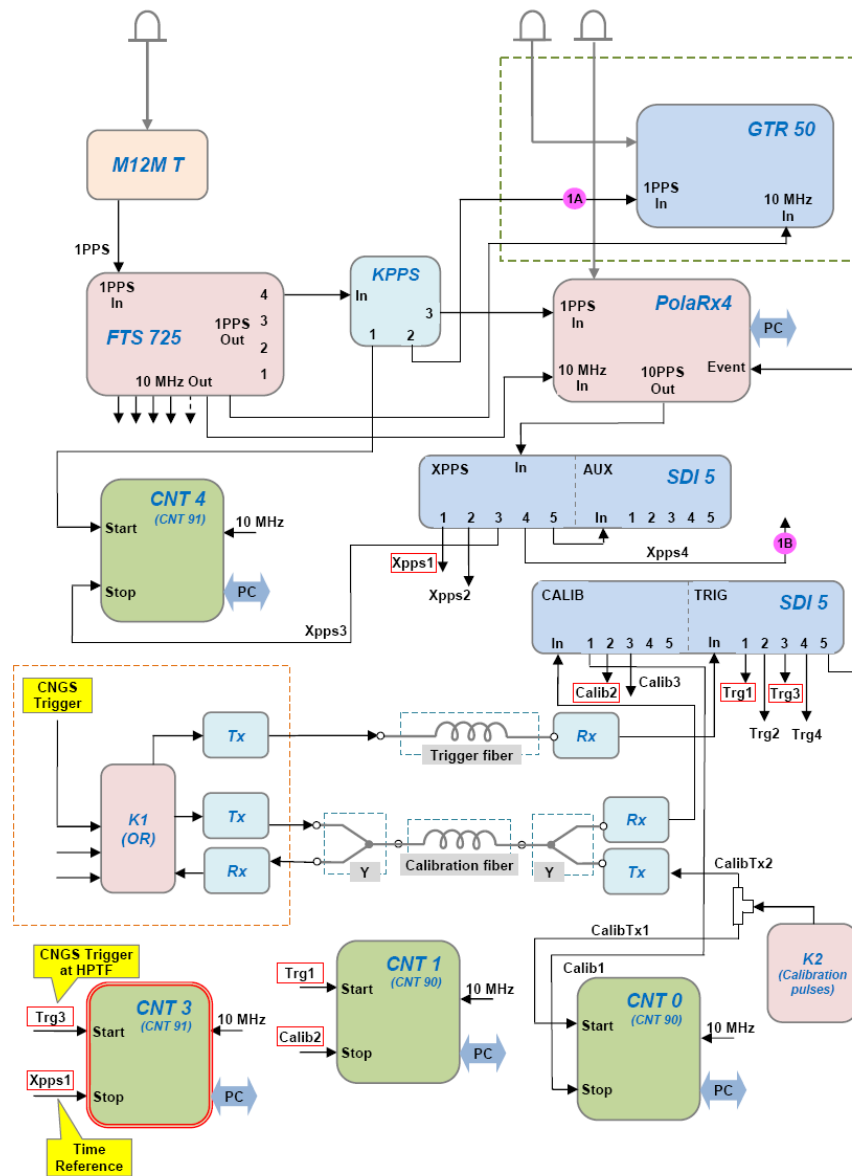

Figure 2. The High Precision Time Facility (HPTF).

III. HPTF-CERN LINK CALIBRATION

The calibration of the GPS time link between HPTF and CERN has been carried out in “link mode” [2]. In particular, this approach involves the receivers at both laboratories (a PolaRx4TR at LNGS and a PolaRx2eTR at CERN, both produced by Septentrio), and a reference or traveling receiver (TR) that is circulated between the two Laboratories and is set in “common clock” and “near zero baseline” (antennas very close) set-up with the local receivers. The TR (DICOM GTR50) is not continuously available at LNGS, but it has been provided by INRIM in order to perform the required calibration. The GPS link calibration value (GPSCAL) for the couple of receivers hosted at CERN and LNGS Laboratories is calculated by the simple difference of the so-called common clock difference results, using the ionosphere free P3 data, generated with the R2CGGTTS V5.0 software developed at the time section of the Royal Observatory of Belgium, and the PPP data, generated with the NRCAN PPP 1087 software developed at the Geodetic Survey Division of Natural Resources Canada. Similarly to what was done at LNGS, at CERN, 1PPS output signal of a Septentrio PolaRx2 GPS receiver is considered as LST and is provided to a measurement system called CTRI, a device that timestamps the 1PPS with respect to a GPS disciplined rubidium clock, providing the timing signal for the accelerator system at CERN. Thus, the timing signal of the accelerator can be referenced to the PolaRx2 receiver measurement. The internal oscillator of the PolaRx2 receiver is synchronized with the 10 MHz frequency of a commercial cesium clock. All the measurements of received GPS signals are made with respect to this internal time scale. In Figure 3, the schematic of the system deployed at CERN is shown.

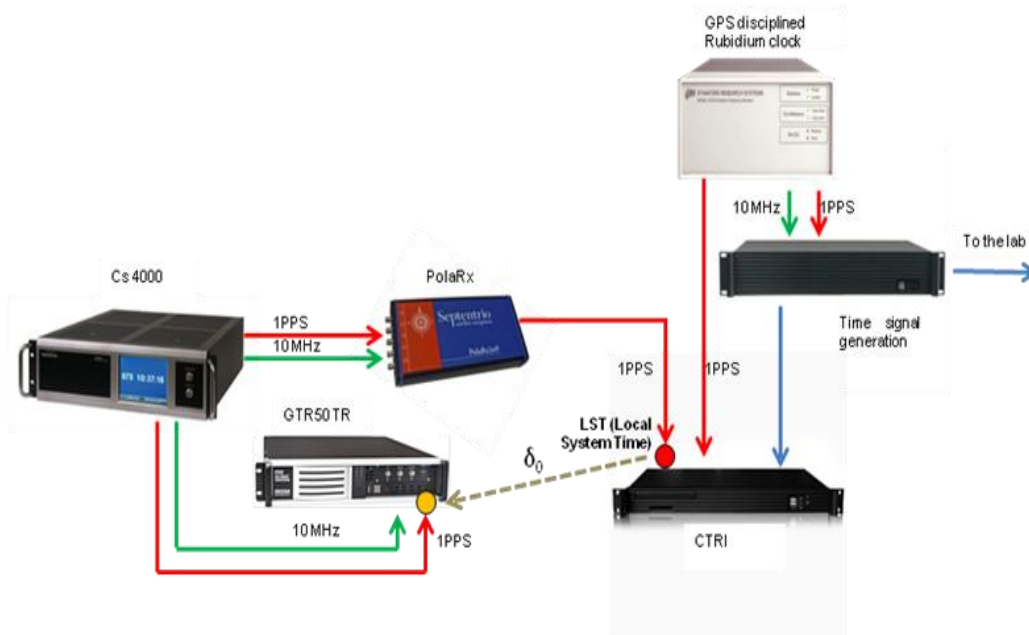

Figure 3. LST generation system at CERN. It is the equivalent of LNGS HPTF.

IV. HPTF CALIBRATION RESULTS

All the delays internal to the HPTF system have been measured with sub-ns precision, during HPTF assembly and calibration done at INRIM and during final installation at LNGS. In particular, the Rubidium standard, the electronic Time Interval Counters and the 1PPS signal distribution systems have been characterized. Furthermore, all of the coaxial cable and optical fiber delays have been measured by INRIM. The GPS time link between CERN and LNGS (called GPS CAL) has been calibrated by INRIM and ROA with an uncertainty at level of 1.1 ns, in agreement with what was achieved for the calibration of the links between receivers hosted at Time and Frequency Laboratories in the frame of the computation of the TAI and UTC time scales by BIPM.

In the next Figures, specific details mainly related to the calibration of the CERN-HPTF GPS link are presented, in terms of Common Clock Differences (CCD) at CERN and LNGS with respect to TR and their stability (Figure 4 and Table 1-top) and GPS CAL time like calibration values (Table 1-below).

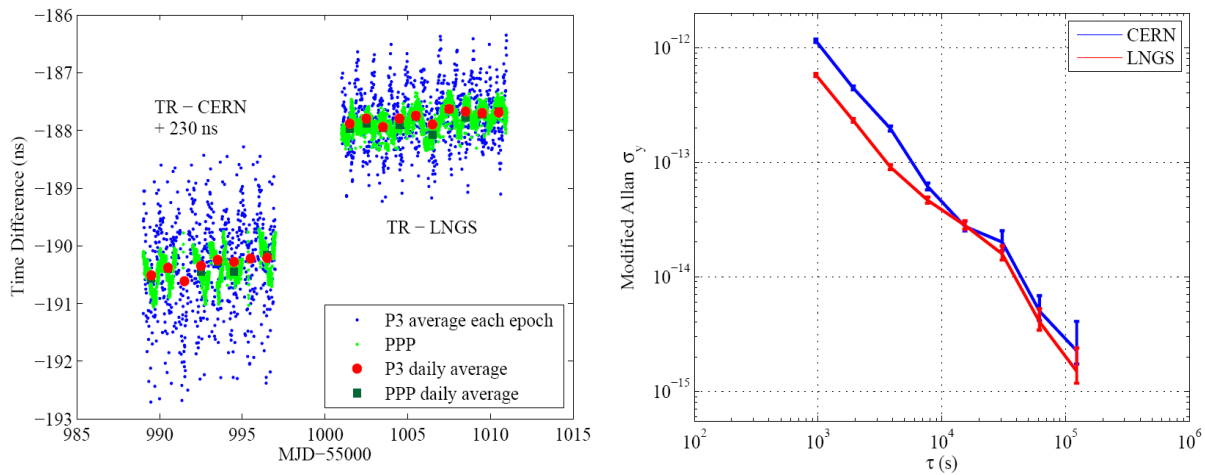

Figure 4. Common Clock Differences (CCD) at CERN and LNGS with respect to TR and their stability.

Table 1. Common Clock Differences (CCD) at CERN and LNGS with respect to TR and GPS CAL time like calibration values.

CCD	P3/ns		Daily average P3/ns		PPP/ns		Daily average PPP/ns		Number of Data P3/PPP
	Mean	SD	Mean	SD	Mean	SD	Mean	SD	
TR – CERN	-420.35	0.82	-420.35	0.15	-420.38	0.27	-420.38	0.14	702/1707
TR – LNGS	-187.77	0.50	-187.77	0.11	-187.83	0.21	-187.83	0.14	880/2773

GPS LINK	GPSCAL P3/ns	GPSCAL PPP/ns
CERN – LNGS	232.6 ± 1.1	232.6 ± 1.1

V. AUTOMATIC PROCESS AND MONITORING SYSTEM AT INRIM AND ROA

Once the GPS link calibration has been computed, an automatic P3/NRCan PPP based processing system has been implemented to daily compute the GPS link corrections, intended as the calibrated (“corrected”) time difference between the reference clocks at CERN and LNGS. In particular, the system has been set at ROA and INRIM premises, considering the computations carried at the Spanish Institute as the “official” ones, while the automatic computations done at the Italian Institute have been used for support/crosscheck of the nominal estimates. Furthermore, ROA estimates have been included in the automatic processing system running at LNGS in the Borexino High Precision Timing Facility (HPTF) calibrated by INRIM. At INRIM, a similar system has been set up, using the NRCan PPP algorithm and an ODTs (Orbit Determination and Time Synchronization) tool [3] developed by the Spanish aerospace company GMV in collaboration with INRIM, yielding time estimates with a reduced latency time, up to

half an hour after the last RINEX files availability. PPP and ODTS estimates have not been considered calibrated, being the main aim of this contribution to monitor in almost real-time the behavior of the clocks at CERN and LNGS and to notify Borexino people about potential anomalies affecting their system. In Figure 5, the ODTS algorithm webpage is reported, showing the CERN and LNGS reference clocks compared with respect to some of international realizations of UTC (namely in Italy, Spain, Germany, Belgium, Sweden and United States).

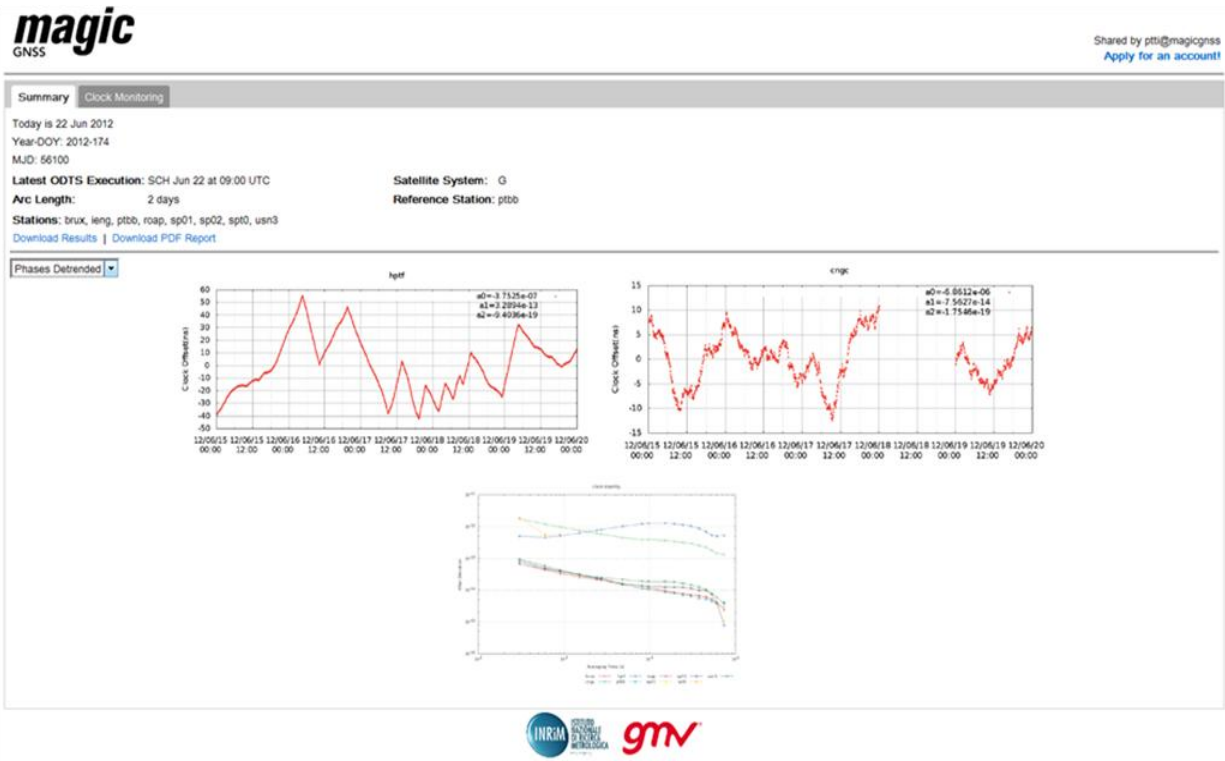

Figure 5. ODTS algorithm webpage showing the CERN and LNGS reference clocks compared with respect to some of international realizations of UTC (namely in Italy, Spain, Germany, Belgium, Sweden and United States).

VI. CONCLUSION

Setting up and calibrating HPTF internal delays, as well as the GPS link with respect to CERN, allowed the measurement of the speed of muon neutrinos with the Borexino detector using short-bunch CNGS beams. The final result for the difference in time-of-flight between a $\langle E \rangle = 17$ GeV muon neutrino and a particle moving at the speed of light c is $dt = (0.8 \pm 3.0)$ ns (being $u = (u_A^2 + u_B^2)^{0.5}$ with $u_A = 0.7$ ns and $u_B = 2.9$ ns), well consistent with zero [4]. Similar results have been achieved by ICARUS [5] and LVD cooperations, that used the reference signals provided by HPTF.

REFERENCES

- [1] B. Caccianiga, et al., "GPS-based CERN-LNGS time link for Borexino," 2012 JINST 7 P08028, August 2012.
- [2] H. Esteban, J. Palacio, A. Bauch, D. Piester, G. Cerretto, and T. Feldmann, "EURAMET Project 1156, GPSCALEU: Results of two years GPS receiver calibration campaign," 26th European Frequency and Time Forum, Gothenburg, Sweden, 2012.
- [3] G. Cerretto, A. Perucca, P. Tavella, A. Mozo, R. Piriz, and M. Romay, "Network Time and Frequency Transfer with GNSS Receivers located in Time Laboratories," IEEE Transactions on Ultrasonics, Ferroelectrics, and Frequency Control, vol. 56, no. 11, November 2009.

- [4] P. A. Sanchez, et al., “Measurement of CNGS muon neutrino speed with Borexino,” Preprint submitted to Physics Letter. B, August 2012.
- [5] M. Antonello, et al., “Precision measurement of the neutrino velocity with the ICARUS detector in the CNGS beam,” Preprint submitted to JHEP, September 2012.

