

Activity Report from NICT

Yuko Hanado, Kuniyasu Imamura, Tsukasa Iwama, Ryuichi Ichikawa, Mamoru Sekido,
Tadahiro Gotoh, and Toshio Iguchi

National Institute of Information and Communications Technology,
4-2-1, Nukuikita, Koganei, Tokyo, 184-8795, Japan

yuko@nict.go.jp

Abstract—The Space-Time Standards Laboratory at the National Institute of Information and Communications Technology (NICT) actively promotes the researches for generating, measuring, and supplying the precise time and frequency standards. For example, Cs primary frequency standards, optical clocks, and precise transfer techniques using optical fiber and satellites have been developed. New approaches such as advanced optical clocks, THz standard, highly precise satellite-link techniques, and VLBI time and frequency transfer have also begun. In addition, generation and services of Japan Standard Time have been keeping the high quality during its long time operation period. An overview of these activities is presented in this paper.

Key words: NICT, activity report, atomic clock, Japan Standard Time, time and frequency transfer

I. INTRODUCTION

The National Institute of Information and Communications Technology (NICT), an incorporated administrative agency, was established in 2004 with its large part inherited from the Communications Research Laboratory (CRL). The activity of time and frequency standards is conducted within the Space-Time Standards Laboratory of the Applied Electromagnetic Research Institute, this group itself comprised of four groups as follows. Firstly, the Atomic Frequency Standards Group develops atomic clocks ranging in frequencies from microwave to the optical region. Specifically, Cs fountain primary frequency standards, a single Ca⁺ ion trap optical clock and a Sr optical lattice clock are originally developed. In addition, research in THz frequency standards has recently begun. The second group is the Japan Standard Time Group, which is responsible for generation of Japan Standard Time, its dissemination, and a frequency calibration service as a national authority. Thirdly, the Space-Time Measurement Group at Koganei develops precise time and frequency transfer techniques using optical fiber and satellite links. In addition, a multi-technique space-geodetic analysis software is under development in this group. Lastly, the Space-Time Measurement Group at Kashima specializes in VLBI research using a 34 m antenna, and has recently begun research into VLBI precision time transfer. Details of these activities are described in the following sections.

II. CESIUM ATOMIC FOUNTAIN NICT-CsF1 & CsF2

NICT has been developing Cs atomic fountain frequency standards for purposes of contributions to the determination of TAI as well as frequency calibration of Japan Standard Time and optical frequency standards. The first fountain (NICT-CsF1) has been in operation since 2006 and twelve accuracy evaluations using CsF1 have been carried out, following the same procedure described in the first evaluation report circulated to the working group on the primary frequency standard in 2007 and also in [1]. So far, a typical frequency uncertainty is 1.4×10^{-15} . Due to a recent vacuum system overhaul and improvement it is now possible to capture more atoms than before, resulting in an improved short-term stability of $6 \times 10^{-14} / \tau^{1/2}$. However, this high atomic density is associated with a large collisional shift. To reduce the collisional shift CsF1 is currently operated with a reduced atomic density in normal operation, and has a short term stability of $2 \times 10^{-13} / \tau^{1/2}$. Installation of rapid adiabatic passage process [2] would enable both high frequency stability and accuracy. Additionally, following the new approach proposed in [3], we are currently re-evaluating the distributed cavity phase (DCP) shift. Recent construction of a

second fountain (NICT-CsF2) attaining the goal of operation at the 10^{-16} level is fuelled by dual purposes. Firstly, two fountains allow vital inter-comparison evaluation of frequency shifts and their associated uncertainties. Secondly, another fountain provides redundancy necessary for guaranteed contribution to TAI. In contrast to CsF1 which uses a (0,0,1) laser cooling geometry with quadrupole magnetic field, CsF2 adopts (1,1,1) geometry enabling many atoms to be captured without a magnetic gradient in large diameter laser beams, resulting in a reduction in the atomic density and thus a smaller collisional shift. Currently CsF2 has a frequency stability of $3 \times 10^{-13} / \tau^{1/2}$ and averages down to a statistic uncertainty at the 10^{-16} level. When used with the currently operational CsF1, this additional fountain clock allows accurate evaluation of frequency shifts and uncertainties between fountains. We have completed evaluations of most systematic frequency shifts and their uncertainties for CsF2 at a level below 5×10^{-16} , and the remaining measurements for microwave related shifts are currently underway.

III. OPTICAL CLOCKS

A. Ca^+ single ion trap

NICT has improved the experimental setup in several ways for the $^{40}Ca^+$ ion trap after our first report of the absolute transition frequency in 2008 [4]. Firstly, photoionization is now used to increase production efficiency of $^{40}Ca^+$ ion trapping. Secondly, a two-layer magnetic shield has been installed on the vacuum chamber. Thirdly, mechanical and acousto-optic modulator shutters were installed to ensure thorough reduction in coupling of the cooling laser to the clock transition. Lastly, a fiber noise cancellation technique has been implemented. These improvements resulted in an observed spectral line width of the clock transition of about 30 Hz.

The clock transition frequency was evaluated by microwave link to International Atomic Time (TAI) in more than ten measurement campaigns over the past year. The measured frequency of 411 042 129 776 398.4 (1.2) Hz [5] agrees with the CIPM recommendation [6]. Furthermore, using optical comparison against a Sr lattice clock locally available in NICT [7] enabled measurement of the frequency ratio of the $^{40}Ca^+$ transition to that of the Sr lattice clock. The result of 0.957 631 202 358 0499 (23) with fractional uncertainty of 2.4×10^{-15} agrees with the frequency ratio separately evaluated by microwave links to the SI second [5]. The measured absolute frequency has a disparity of more than three times as big measured uncertainty as two other published results. We are preparing a frequency comparison between two separated $^{40}Ca^+$ ions for a confirmation of our measurement. This result was reported and adopted in CCTF-GA 2012; consequently it contributed the recommended values of standard frequencies to the update.

B. Sr lattice clock

A lattice clock based on the $^{87}Sr \ ^1S_0-^3P_0$ transition started operation in 2011. A vertically oriented one-dimensional lattice is employed for recoil-free confinement. Referring to the TAI, the absolute frequency of the transition was measured to be 429 228 004 229 873.9 (1.4) Hz [7]. This frequency agrees with those measured in other four institutes; JILA, SYRTE, U. Tokyo-NMIJ, and PTB. The systematic fractional uncertainty of 5×10^{-16} is mainly comprised of blackbody radiation shift, collisional shift, 2nd order Zeeman shift and lattice stark shift. The agreement with the clock at University of Tokyo (UT) is also confirmed by an optical fiber link [8]. A 60 km-length of dark fiber between NICT and UT is used for the all-optical direct frequency comparison. The frequency difference of 3.7 Hz is predominantly due to the elevation difference of 56 m. The residual difference after the subtraction of the systematic corrections is smaller than the total systematic uncertainty of two clocks (7×10^{-16}) demonstrating the reproducibility of lattice-based clocks [9]. This result was reported and adopted in CCTF-GA 2012; consequently it contributed the recommended values of standard frequencies to the update.

C. New approach

An optical frequency standard based on a single $^{115}In^+$ is being developed at NICT with an expected inaccuracy on the order of 10^{-18} for the $^1S_0-^3P_0$ transition at 237 nm [10]. Three new approaches will be

employed to compensate the relatively small transition rate of its cooling and detection transition ($^1S_0-^3P_1$, 230 nm). They include (a) use of a clock laser stabilized to a Sr optical lattice clock [11], (b) detection by quantum logic spectroscopy and its derivatives, and (c) detection by excitation of the vacuum ultraviolet (VUV) transition ($^1S_0-^1P_1$, 159 nm) by coherent pulses generated by high harmonic generation (HHG) of a femto-second laser. These three methods are applied to an $^{115}\text{In}^+$ that is sympathetically cooled with $^{40}\text{Ca}^+$ in a linear trap. Basic technologies for generating the ion chains consisting of $^{115}\text{In}^+$ and $^{40}\text{Ca}^+$ have been developed, and the first frequency measurement is planned for 2014.

IV. THZ FREQUENCY STANDARD

NICT has started to establish a new frequency standard in the THz (0.1 - 10 THz, wavelength 30 μm - 3 mm) domain. The THz frequency comb with a photoconductive antenna using 1.5 μm femto-second fiber lasers has been developed for the absolute THz frequency measurements. Its measurement accuracy has attained to 10^{-16} level around 0.3 THz, which corresponds to a frequency resolution of 30 μHz . The present accuracy is limited by the electric noise of a current-to-voltage conversion amplifier. In theoretical research, a THz quantum standard based on vibrational transition frequencies of optically trapped molecules was proposed to attain the uncertainty level of 10^{-16} around 10 THz [12, 13].

V. JAPAN STANDARD TIME

A. Atomic time generation

UTC(NICT), the basis of Japan Standard Time, is a realization of an average timescale comprising of an ensemble of more than ten Cs atomic clocks (Symmetricom, Inc. "5071A") at NICT headquarters in Tokyo [14]. The ensemble timescale is calculated by a program that estimates the clock rate from the last 30-day trend, and weights each clock according to its Allan deviation at the averaging time of 10 days. If any individual clock suddenly changes more than 1×10^{-14} it is considered anomalous and its weighting to the average becomes zero. This Cs ensemble timescale makes the self-reliant timescale TA(NICT) by coupling with the Cs Fountain NICT-CsF1. For the realization of this Cs ensemble timescale, an Auxiliary Output Generator (AOG) phase-locked to a hydrogen maser is used. We have 4 hydrogen masers produced by Anritsu Corporation and one of them is used as the source of UTC(NICT). The AOG is automatically steered every 8 hours to trace the Cs ensemble timescale, and is manually steered to trace UTC if necessary. The 5 MHz signals from all clocks in the Cs ensemble are measured using a 24-ch DMTD system with precision of 0.2 ps [15]. Phase data is measured in addition to the frequency data using one pulse per second (1 PPS) signals to prevent a cycle-slip mistake. For robustness, the main parts of the system have three redundancies; atomic clocks and main devices are supplied with a large UPS, a generator which has sufficient fuel to maintain power for three days; and the building itself incorporates quake-absorbing technologies. Figure 1 shows the generation system of UTC(NICT) [16], and Figure 2 shows the frequency stability of UTC(NICT) calculated from the data during 2009 - 2011.

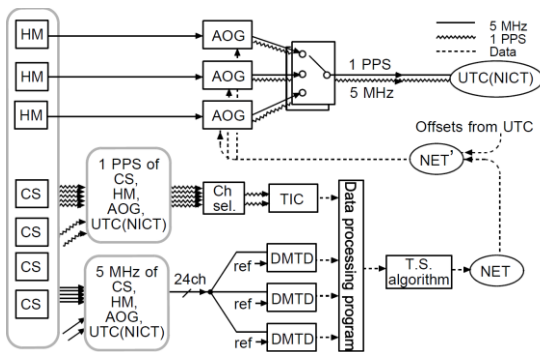

Figure 1. Generation system of UTC(NICT). Here, "NET" is NICT-Cs-ensemble-time.

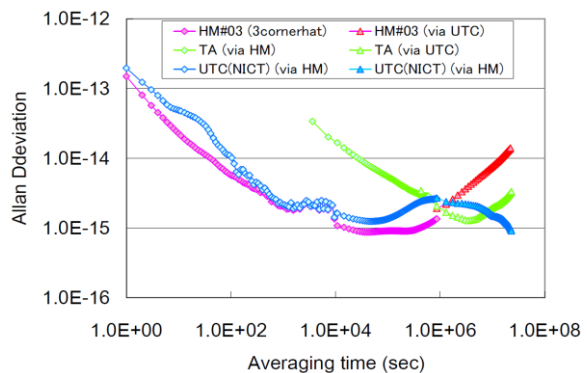

Figure 2. Frequency stability of UTC(NICT) compared with H-maser and Cs ensemble time (TA).

B. Dissemination

NICT provides a dissemination service of standard-frequency and time-signals via the LF band, as shown in Figure 3. The values under the distance (km) shows the approximate strength calculated as the assumed electric field. Signals from the two LF stations, Ohtakadoya-yama and Hagane-yama, entirely cover Japan. Table 1 shows the characteristics of the stations, both of which operate 24 hours a day. A consumer market of radio controlled watches and clocks has been developed. The Ohtakadoya-yama station is located within 20 km from the Fukushima 1st nuclear power plant. When the power plant suffered damage from the tsunami resulting from the March 2011 earthquake, staff were evacuated from Ohtakadoya-yama station and operation suspended for 40 days. Following this incident, remote control functions have been implemented to maintain operation.

In 2006 NICT began the public Network Time Protocol (NTP) service using a Field Programmable Gate Array (FPGA)-based NTP server which can accept up to one million NTP requests per second. Because this server is implemented on a PCI card, a host PC is required to initialize and check the server operation. In 2008 NICT introduced a stand-alone server which includes a Linux controller unit integrated on the FPGA together with the hardware of NTP server. NICT received more than 170 million accesses to the NTP servers per day in October 2012.

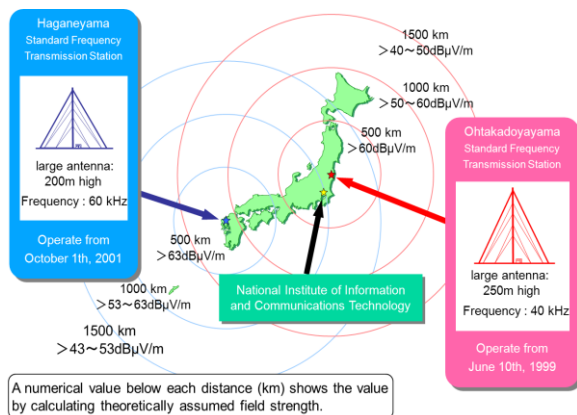

Figure 3. LF time and frequency service stations in Japan.

Table 1. Characteristics of LF stations.

	Ohtakadoya - yama	Hagane -yama
Frequency	40 kHz	60 kHz
E.R.P	13 kW	23 kW
Antenna	250 m height	200 m height
Latitude	37°22' N	33°28' N
Longitude	140°51' E	130°11' E

C. Frequency calibration system for traceability

NICT has been conducting a frequency calibration service referenced to UTC(NICT). In order to fulfill the requirements of global MRA, NICT was certified in accordance with the ISO/IEC 17025 from the National Institute of Technology and Evaluation (NITE) in March 2001. NITE provided NICT with ISO/IEC 17025 accreditation for the frequency calibration system on 31 January 2003, the frequency remote calibration system on 2 May 2006, and the time scale difference on 30 September 2011. Best Measurement Capability (BMC) of carried-in system was changed to 5×10^{-14} in April 2007. The measurement range of frequency calibration was expanded from 1 Hz to 100 MHz in September 2011.

The first CMC table was approved and registered in the Key Comparison Database (KCDB) in August 2005. A revised CMC table was also submitted and registered in the KCDB in November 2009. A springboard of guidelines for CMC tables was prepared for the discussion at the TCTF technical workshop held at NICT before APMP2011.

D. Trusted time stamping service

The accreditation program for time stamping services in Japan began in February 2005. In this program, the clock of the time stamping server is calibrated within the prescribed accuracy and traceability to UTC(NICT) for every issued time stamp to be assured. The clock accuracy of the time stamping server is prescribed to be 1 second or better to UTC(NICT). NICT is the official time supplier for this accreditation

program. NICT also contributes to standardization of the Time Stamping Service. The NICT proposal “Trusted time source for time stamp authority” satisfied the approval procedures of ITU-R and was approved as Recommendation ITU-R TF, 1876 in April 2010.

E. New approach

To improve reliability we plan to develop a distributed generation system of Japan Standard Time. In this system, atomic clocks at some distant station will be connected using satellites or optical fiber links, and an ensemble timescale will be constructed at each station using all these distributed clocks. These ensemble timescales are expected to be approximately the same. In this manner even if NICT headquarters suffers a disaster and suspends operation, atomic clocks and the continuity of Japan Standard Time will be maintained. Preparation has begun this year 2012 on the first station at the Kobe branch of NICT. Another new theme is to make a generation system adaptable to higher frequencies. The operating frequency of the current system is essentially 5 MHz, but this frequency is too low to match the system of optical clocks. As intermediate frequencies linking optical clocks should be at least in the GHz region, we will develop a precise measurement system with 1 GHz operating frequency.

VI. TIME TRANSFER

A. GPS

NICT has been operating two Septentrio PolaRX2 TR receivers for the TAI time comparison network, and GPS carrier phase observations are continuously provided for computation of TAI. Accurate troposphere delays were calculated in order to improve time transfer precision of GPS carrier phase. These troposphere delay computations are computed by Kashima Ray-tracing Tools (KARAT) for which we developed PPP software, concerto v4 [17]. NICT and the Wuhan Institute of Physics and Mathematics (WIPM) performed the first optical clock comparison experiment using GPS PPP and directly compared both Ca⁺ single ion trap clocks.

B. TWSTFT

NICT has organized the Asia-Pacific Rim TWSTFT link, currently utilizing the satellite GE-23, to monitor atomic clocks located in two domestic low-frequency stations. Before March 2011 the satellite IS-8 had been used. In this link, time transfer is performed once every hour using the NICT modem. Additionally, in 2010 an Asia/Hawaii link was established using the same satellite. The Hawaii station is equipped with a hydrogen maser and two antennas for Asia and North America. Time transfers between NICT, TL, and USNO are performed once every hour using the SATRE modem that joins the two links. The Asia-Europe TWSTFT link is cooperatively constructed by major T&F institutes in Asia: NICT, TL, NIM, NTSC, KRISS, NMIJ, NPLI, and two European institutes: PTB and VNIIFTRI [18]. The link had been established by the satellite IS-4 until the beginning of 2010. However, due to the malfunction of IS-4 it was switched to the satellite AM-2 in October 2010. The working time of the transponder is limited from 13:00 UTC to 23:00 UTC. During this period time transfer is performed once every hour using the SATRE modem, and the data are regularly reported to BIPM. NICT-PTB, TL-PTB, NTSC-PTB and NPLI-PTB links have been adopted for calculation of UTC(k), respectively. It is reported that satellite AM-2 is nearing the end of its operational lifetime, so we are considering the switch to another satellite.

C. Fiber transfer

An optical carrier transfer system was developed in NICT to improve the transfer stability over those systems using RF transfer in optical fibers [19, 20]. To realize direct optical clock comparison, we developed an all-optical link system that consists of Ti:S optical frequency combs to bridge the frequency gap between the clock transition and telecom wavelength, fiber amplifiers, an active polarization control system and an optical carrier transfer system [21]. 1.5 μm light was stably transferred through a 90 km urban fiber link and fiber noise canceled to the theoretical limit. Transfer stability was 2×10^{-15} at 1 sec and 4×10^{-18} at 1000 s as measured by a Π-type frequency counter.

NICT was connected with the University of Tokyo (UT) through a 60 km urban fiber link. The ⁸⁷Sr lattice clocks developed at NICT and UT were compared [22]. Figure 4 shows the stability of two ⁸⁷Sr clocks (blue line) and instabilities of the all-optical link system (black line) and the optical carrier transfer system (red line) measured by a Π -type counter. It proved that the all-optical link system does not put any restrictions on the frequency comparison. The system included fiber amplifiers whose physical fiber length was not stabilized. When more stable optical clocks are to be compared, further improvement on the system and a noise-less optical fiber link will be necessary.

For RF transfer NICT developed a commercially-available 10 MHz transfer system. The target transfer length was a few tens of kilometers and transfer stabilities of 4×10^{-13} at 1 sec and 1×10^{-16} at 1 day were achieved. The system is appropriate for stable reference signal transfer, such as that demanded by VLBI systems.

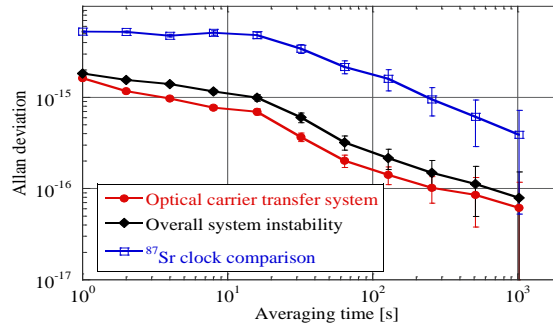

Figure 4. Frequency instability of direct clock comparison and system as measured by a λ -type counter.

D. Advanced TWSTFT (DPN and carrier-phase)

NICT has developed a new two-way time transfer modem with an arbitrary wave form generator and a versatile A/D sampler. Most of the digital signal processing is done by graphics processing units (GPU) on the host computer. As a consequence, the modem is less expensive and has flexibility for the timing signal. Dual pseudo-random noise (DPN) signals were adopted for the modem, where two coded signals with a lower chip rate are used with separately-allocated frequencies. In this scheme, spreading the signals with a gap frequency is equivalent to using a wider chip rate signal. We achieved a measurement precision of 16 ps using 128 kbps coded signals with a frequency separation of 20 MHz in the first DPN TWSTFT experiments [23]. NICT and TL have occasionally performed DPN TWSTFT in the GE-23 North East Asia beam link, and the achieved time transfer stability is shown in Figure 5 [24].

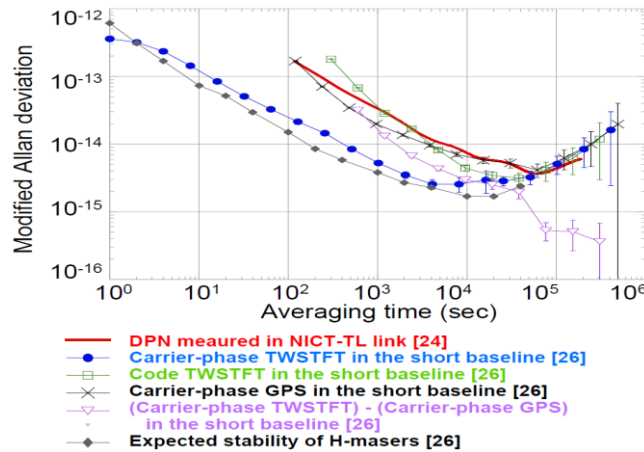

Figure 5. Frequency stabilities of DPN and carrier-phase TWSTFT.

For further improvement of measurement precision, NICT has started development of carrier-phase TWSTFT [25]. The phase difference is derived from carrier phase information of the signals sent from the counterpart station and one's own station. In a common clock measurement via a satellite link, a measurement precision of 0.2 ps is achieved, which may be limited by phase jitters induced by the frequency converters. In a short baseline with a length of 150 km a measurement precision of 0.4 ps is achieved and the time variation showed good agreement with the results of GPS carrier phase. Figure 5 shows the resultant frequency stabilities. The evaluation in a longer baseline is planned as a next step.

VII. VLBI FOR TIME AND FREQUENCY TRANSFER

For one of the tools for time and frequency transfer, NICT has been investigating potential of VLBI in application to T&F transfer. Figure 6 shows the results of T&F transfer inter-comparison experiments performed between Kashima-Koganei, 100 km distance, on 19-23 February 2012. This experiment was carried out to test the feasibility of VLBI with 11m diameter antennas. The clock difference between two hydrogen masers at each site was compared with GPS, VLBI, and TWSTFT (Code) in this experiment. In this plot, each point of TWSTFT (Code: green cross) is the value obtained by taking the average of every one second raw data for 1 min. Those of GPS (red cross) are the data at every minute. For the case of VLBI (blue closed circle and black open square), each point is obtained by averaging for 30 sec. Arbitrary offsets are removed from each measurement datum, and parabolic behaviors of the clocks are commonly removed from all the data in this plot. The VLBI result demonstrates a smaller daily variation than TWSTFT (Code) in this experiment. The clock jump at each day boundary is due to the discontinuity of the orbital information on the GPS satellite. It is notable that the increasing observation bandwidth in VLBI data from 500 MHz (blue closed circle) to 1 GHz (black open square) improves the precision of clock difference measurements. This encourages the plan to develop wideband VLBI system, which is the target of our VLBI T&F transfer project.

For using the VLBI technique in time and frequency transfer, we are developing small-diameter antennas for a wideband VLBI system. The new wideband VLBI system is semi-compliant with next generation VLBI specification "VLBI2010," which is promoted by the International VLBI community.

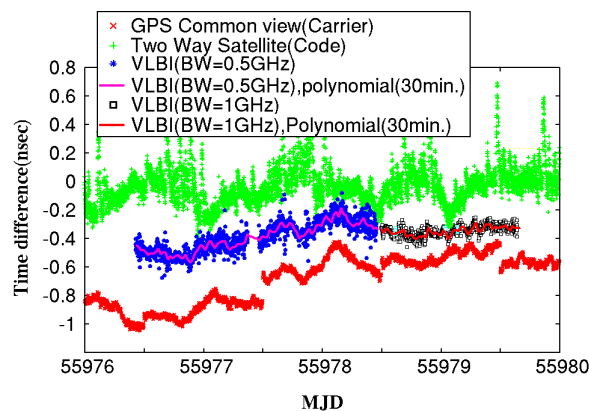

Figure 6. Inter-comparison of multiple time and frequency transfer techniques on Kashima - Koganei 100km distance.

VIII. DEVELOPMENT OF A MULTI-TECHNIQUE SPACE-GEODETIC ANALYSIS SOFTWARE

Otsubo et al. [26] have developed an analysis software package based on Java named CONCERTO4 which enables the user to consistently process GNSS, SLR, and other satellite tracking data. Driven by the need to update the software and to replace the existing Java code, VLBI was added as an additional module to this analysis package, which was renamed to "c5++" in 2010 [27]. The software complies with the latest IERS conventions [28] and provides state-of-the-art modules for a variety of geodetic,

mathematical, and geophysical tasks. As shown in Figure 7, modules of c5++ can be used for processing of single technique solutions or these modules can be combined for multi-technique analysis. As for the latter option, combination of data is being carried out on the observation level, which ensures utmost consistent processing of space geodetic observations. Moreover, common parameters (clocks, troposphere, orbits) between different techniques can be estimated in one single adjustment process. This allows for gaining maximum benefit from each technique and compensates for the deficits that a single technique might have. As for frequency transfer applications, the combination of GPS and VLBI with c5++ is anticipated to provide high stability on short- and long-term time scales.

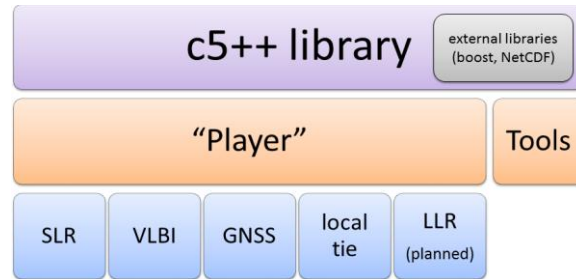

Figure 7. The concept of c5++.

IX. CONCLUSION

The Space-Time Standards Laboratory at NICT has developed the state-of-the-art techniques in the fields of time and frequency standards, and also has maintained the reliable Japan Standard Time with high quality. This accumulation of all-round basic techniques and experiences in one laboratory is our significant feature, which is also effective and advantageous in the total evaluation of new developed techniques. We keep challenging to realize more precise time and frequency standards and related techniques in THz and optical regions.

X. ACKNOWLEDGEMENTS

The authors greatly appreciate the contribution of M. Kumagai in Section II, T. Ido, K. Matubara, and K. Hayasaka in Section III, S. Nagano and H. Ito in Section IV, M. Fujieda in Section VI, and T. Hobiger in Section VIII. The results and successes presented in this paper have been achieved by the efforts of all the members of Space-Time Standards Laboratory both in current and past years.

REFERENCES

- [1] M. Kumagai, H. Ito, M. Kajita, and M. Hosokawa, "Evaluation of Caesium Atomic Fountain NICT-CsF1," *Metrologia* 45 (2008) 139-148.
- [2] F. Dos Santos, H. Marion, S. Bize, Y. Sortais, A. Clairon, and C. Salomon, "Controlling the Cold Collision Shift in High Precision Atomic Interferometry," *PRL*, 89, (2002) 233004/
- [3] R. Li and K. Gibble, "Evaluation and minimizing distributed cavity phase errors in atomic clocks," *Metrologia* 47 (2010) 534-551.
- [4] K. Matsubara, et al., *App. Phys. Express*, 1 067011, (2008).
- [5] K. Matsubara, H. Hachisu, Y. Li, S. Nagano, C. Locke, A. Nogami, M. Kajita, K. Hayasaka, T. Ido, and M. Hosokawa, submitted to *Opt. Express*.
- [6] CIPM Recommendation (C2-2009), "Updates to the list of standard frequencies," http://www.bipm.org/cc/CIPM/Allowed/98/REC_CIPM2009_C2_LIST_OF_ST_FREQUENCIES_18_DEC_2009.pdf.

- [7] A. Yamaguchi, et al., *Appl. Phys. Express* 5, 022701 (2012).
- [8] M. Fujieda, M. Kumagai, S. Nagano, A. Yamaguchi, H. Hachisu, and T. Ido, *Opt. Express* 19, 16498 (2011).
- [9] A. Yamaguchi, et al., *Appl. Phys. Express* 4, 802203 (2011).
- [10] M. S. Safronova, M. G. Kozlov, and C. W. Clark, *Phys. Rev. Lett.*, 107, 143006 (2011).
- [11] K. Hayasaka, *Appl. Phys. B* 107, 965 (2012).
- [12] M. Kajita, G. Gopakumar, M. Abe, and M. Hada, *Phys. Rev. A* 84, 022507 (2011).
- [13] M. Kajita, G. Gopakumar, M. Abe, and M. Hada, *Phys. Rev. A* 85, 062519 (2012).
- [14] Y. Hanado and M. Hosokawa, *Japanese Journal of Applied Physics*, Vol. 47, No. 4, pp. 2294-2298, April, 2008.
- [15] F. Nakagawa, M. Imae, Y. Hanado, and M. Aida, *IEEE Transactions on Instrumentation and Measurement*, vol. 54, No. 2, pp. 829-832, April, 2005.
- [16] Y. Hanado, et al., *International Journal of Navigation and Observation*, Article ID 841672, pp.1-7, January, 2008.
- [17] T. Gotoh, T. Hobiger, and R. Ichikawa, *Proc. of International Symposium of GPS/GNSS*, PS04, 2009.
- [18] M. Fujieda, et al., *Proc. of EFTF 2011*, 655-660, 2011.
- [19] M. Kumagai, M. Fujieda, S. Nagano, and M. Hosokawa, *Opt. Lett.*, 34, 19, 2949-2951, 2009.
- [20] M. Fujieda, M. Kumagai, and S. Nagano, *IEEE TUFFC*, 57, 1, 168-174, 2010.
- [21] M. Fujieda, M. Kumagai, S. Nagano, A. Yamaguchi, H. Hachisu, and T. Ido, *Opt. Exp.*, 19, 17, 16498-16507, 2011.
- [22] A. Yamaguchi, et al., *Appl. Phys. Exp.*, 4, 082203, 2011.
- [23] T. Gotoh, J. Amagai, T. Hobiger, M. Fujieda, and M. Aida, *IEEE IM*, 60, 7, 2495-2499, 2011.
- [24] W. H. Tseng, Y. J. Huang, T. Gotoh, T. Hobiger, M. Fujieda, M. Aida, T. Li, S. Y. Lin, H. T. Lin, and K. M. Feng, *IEEE TUFFC*, 59, 3, 531-538, 2012.
- [25] M. Fujieda, T. Gotoh, F. Nakagawa, R. Tabuchi, M. Aida, and J. Amagai, accepted by *IEEE TUFFC*.
- [26] T. Otsubo, H. Kunimori, B. Engelkemier, and F. Takahashi, "Error control of numerical integration in SLR analysis software CONCERTO," *Journal of the Geodetic Society of Japan*, 40, 4, 347-355, 1994.
- [27] T. Hobiger, T. Otsubo, M. Sekido, T. Gotoh, T. Kubooka, and H. Takiguchi, "Fully automated VLBI analysis with c5++ for ultra-rapid determination of UT1," *Earth, Planets, Space*, 45, 2, 75-79, 2010.
- [28] G. Petit and B. Luzum, "IERS Conventions," *IERS Technical Note*, 36, 179 pp., 2010.

