

# CHALLENGES USING IEEE 1588-2008 PRECISION TIME PROTOCOL (PTP) FOR HIGH ACCURACY TIME TRANSFER

**David Wilson**  
**Naval Research Laboratory**  
**Washington D.C.**

## Abstract

*The NRL Space Applications Branch evaluated PTP devices from several vendors to determine their suitability for high accuracy time transfer (< 1 ns) applications. The IEEE Std 1588-2008 Clause 1.1 states “the standard permits synchronization accuracies better than 1 ns.” A time transfer accuracy of 1 ns has proven difficult if not impossible to achieve especially when using PTP devices from different vendors. This paper discusses the challenges of achieving 1 ns time transfer using PTP and possible solutions to these challenges.*

## INTRODUCTION

IEEE Std 1588-2008 PTP is a standard to synchronize a system of distributed clocks with a variety of accuracies, resolutions, and stabilities to within 1 micro-second. The PTP was designed to operate over a localized network with a minimal network infrastructure consisting of a few routers and switches. Other design objectives of 2008 PTP were that it support multicast communications, operate on several different networks types and topologies, and support different transport protocols.

The concept of a “Profile” was introduced in IEEE Std 1588-2008 (version 2 of PTP) to support different time transfer applications. An IEEE 1588 PTP profile is simply an allowable subset of options and “attributes” defined in the IEEE Std 1588-2008 to meet the performance requirements of a particular application. Table 1 below summarizes four PTP profiles for audio and video bridging applications, power system applications, the telecommunications industry, and test and measurement applications. There currently is no PTP profile for high accuracy time transfer applications.

Table 1. IEEE 1588 PTP Profiles.

PTP Application	Industry Trade Association/Standards Organization	Synchronization Type
Audio and Video Across Bridged LANs	IEEE Std 802.1AS-2011	Timing, Phase, Time
Power Systems	IEEE Std C37.238 2011	Time
Telecommunications	ITU-T Recommendation G.8265.1	Timing
	ITU-T Recommendation G.8275.1	Phase, Time
Test and Measurement	LXI (LAN eXtensions) for Instrumentation	Time

NRL assembled a test bed to evaluate PTP devices from several vendors for high accuracy time transfer. Table 2 below shows typical PTP high accuracy time transfer requirements.

Table 2. PTP High Accuracy Time Transfer Requirements.

Specification		
Accuracy (Frequency offset)		$10^{-12}$
Time Domain Stability ADEV $\sigma_y(\tau)$ for a 10 MHz Output	Averaging Time	
	1 sec	$< 10^{-10}$
	10 sec	$< 10^{-10}$
	100 sec	$< 10^{-11}$
	1 day	$< 10^{-13}$

## CHALLENGES TO HIGH ACCURACY TIME TRANSFER USING PTP

Challenges to high accuracy time transfer using PTP is limited by several factors which include oscillator stability, time stamp resolution and accuracy, network topology, transmission media and physical layer device (PHY) asymmetries, and slave clock servo loop design to name a few. There are several research papers [1-3] which discuss these limitations in great detail.

PTP device interoperability poses another significant challenge to using PTP for high accuracy time transfer. PTP devices from the same vendor often work well together but often poorly or not at all when intermixed with PTP devices from other vendors.

## COMMON TIME TRANSFER MECHANISMS

There are four common mechanisms in addition to PTP for transferring time and frequency. The advantages and disadvantages of each time transfer mechanism are discussed below.

### GLOBAL POSITIONING SYSTEM (GPS)

GPS is a global navigation satellite system (GNSS) consisting of a constellation of 24 satellites. Each satellite contains an onboard atomic frequency standard which provides time synchronization accuracy of a few nanoseconds. GPS GNSS signals, however, are very weak, easily jammed, and subject to multipath and shadowing especially in the presence of dense foliage or in urban areas.

### TWO-WAY SATELLITE TIME TRANSFER (TWSTT)

The TWSTT method uses a geostationary satellite to retransmit synchronization signals from two clocks separated by a large distance (often several hundred miles or more). TWSTT is capable of the same nanosecond time transfer accuracy of GPS but has the advantage of not requiring complicated ionospheric and tropospheric models or a precise clock and satellite position. TWSTT does have a few disadvantages compared to GPS. TWSTT requires expensive satellite time and equipment at both clock sites to simultaneously receive and transmit time synchronization signals.

## **NETWORK TIME PROTOCOL (NTP)**

NTP is a protocol to provide time synchronization for a system of networked NTP clients. NTP time transfer accuracy is highly dependent on network infrastructure and NTP client and server hardware. Typical NTP time transfer accuracies range from 10 to 100 ms for WANs and 1 to 10 ms for LANs.

## **INTER-RANGE INSTRUMENTATION GROUP (IRIG)**

IRIG defines a family of rate-scaled serial time codes using six code formats at different pulse rates. IRIG can provide a 1 - 10 micro-second time transfer accuracy using both amplitude modulated and unmodulated IRIG time codes. A drawback to using IRIG for time transfer is IRIG requires dedicated cabling and amplifiers which is too expensive and impractical in some cases.

## **IEEE 1588 TEST BED**

An IEEE 1588 test bed was assembled to test and evaluate grand master clocks (GMC), transparent clocks (TC), boundary clocks (BC), and ordinary slave clocks (SC) from different vendors for high accuracy time transfer. All testing was done on an isolated network.

The IEEE 1588 test bed includes an Ixia XM2 Optixia IP Performance tester, a Stanford Research Systems SR620 Time Interval Counter (TIC), and other standard lab equipment. The IEEE 1588 test bed also includes Symmetricom's TimeMonitor Analyzer analysis and TimeMonitor Measurement data collection software.

The TimeMonitor Measurement software collects time interval error (TIE) measurements from a SR620 TIC of the GMC 1 PPS and SC 1 PPS outputs. The TimeMonitor Analyzer software calculates the time deviation (TDEV), maximum time interval error (MTIE), and Allan deviation (ADEV) from the TIE measurements.

The IEEE 1588 test bed also includes an Ixia Optixia IP performance tester. The Ixia IP performance tester has four dual PHY (RJ-45 and SFP) 10/100/1000 Mbps ports to test layer 2 and 3 high speed, high capacity routers and switches.

The Ixia IP performance tester is capable of testing complex network topologies consisting of thousands of routing and switching devices. The Ixia IP performance tester can emulate millions of routes and reachable hosts within a network topology. The Ixia IP performance tester can also generate layer 2 and layer 3 traffic for device under test (DUT) data plane stress analysis as well as layer 4 through layer 7 performance test applications (HTTP, HTTPS, FTP, TCP, and Impairment features).

The Ixia IP performance tester was purchased with a PTP emulation option which fully implements IEEE Std 1588-2008 PTP. The Ixia IP performance tester closely simulates a "real world" network to thoroughly test the interoperability, time transfer accuracy, and scaling of any PTP device. The following section describes several tests to evaluate PTP devices for high accuracy transfer.

## PTP DEVICE TESTS

### GMC TO SC “SWITCH FREE” DIRECT TIME TRANSFER TEST

The GMC to SC “switch free” direct time transfer test measures the time transfer accuracy of a GMC connected directly to a SC with a crossover cable. The direct time transfer test provides a “best case” baseline time transfer measurement. Figure 1 shows the test setup for the GMC to SC direct time transfer test. The GMC 1 PPS output to SC 1 PPS output offset for four direct time transfer tests is shown in Figures 5 through 8.

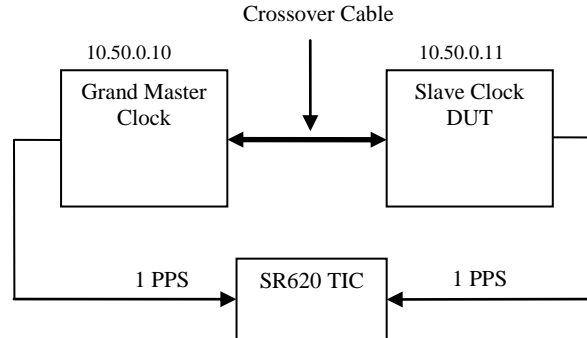

Figure 1. GMC to SC “Switch Free” Direct Time Transfer Test.

The GMC to SC time transfer test through an end-to-end TC measures how well a GMC can synchronize to a SC through an end-to-end TC both with and without network traffic injected into the TC. Time critical event messages such as Sync and Delay\_Request PTP messages experience latency when they pass through a TC in the presence of PTP multi-cast or stateless layer 2 and 3 traffic. If the network is heavily loaded the TC latency could be long enough to affect the slave clock’s ability to synchronize to the GMC. Figure 9 shows how network traffic affects the performance of a TC.

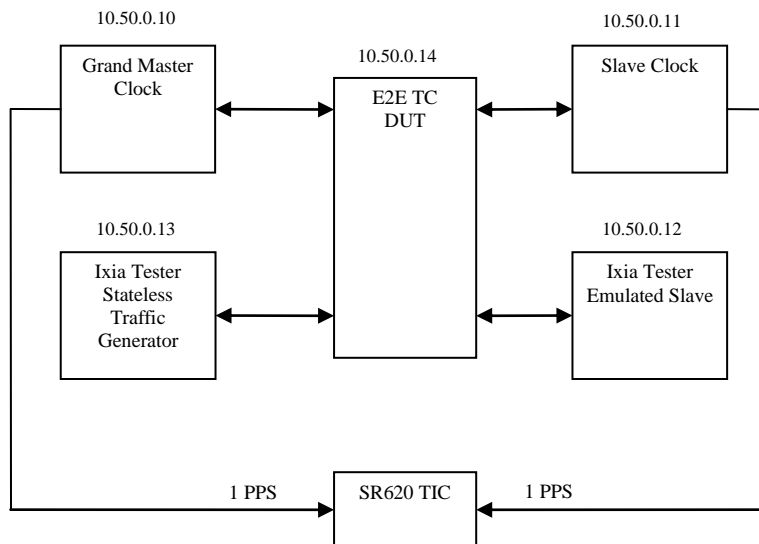

Figure 2. GMC to SC Time Transfer Test through an End-to-End TC With and Without Network Traffic.

## PTP SCALABILITY TEST

The PTP scalability test can emulate up to 500 SC's to determine the maximum number of slave clocks a GMC or BC can handle in the presence of network traffic. The maximum number of emulated SC's a GMC and BC is reached when there is noticeable packet loss between the SC and GMC or BC.

The PTP scalability test can be modified to test the DUT scalability with multiple clock domains, in both PTP unicast and multicast mode, and using the one-step and two-step synchronization model.

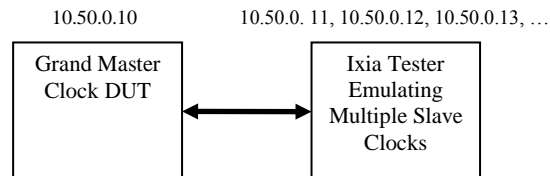

Figure 3. PTP Scalability Test.

## CORRECTION FACTOR (CF) ERROR TEST

The CF factor error test was originally proposed in a paper [1] presented during the ISPCS 2009 Symposium. The CF error test measures how accurately a TC calculates the residence time of Sync and Delay\_Request PTP event messages. The residence time is the time duration an event message is inside a TC before being forwarded to another PTP device.

The Ixia IP performance tester can time stamp to a 20 ns resolution when a PTP packet arrives or leaves one of its RJ-45/SFD ports. Additionally, each Ixia tester RJ-45/SFD port is time synchronized allowing measurement of the transit time of a PTP event message from a one port to another. This is particularly helpful for a packet delay variation measurement which measures the transit time for a PTP packet to go from point A to point B in a network.

The Ixia IP performance tester measures the TC residence time by subtracting the time ( $t_1$ ) a Sync PTP message left a GMC port from the time ( $t_2$ ) the Sync PTP message arrived at a SC port. The TC residence time can also be measured by subtracting the time ( $t_3$ ) Delay\_Request PTP message left the SC port from the time ( $t_4$ ) the Delay\_Request PTP message arrived at the GMC port. All cat 5e cable delays and Ixia IP tester internal delays are measured and subtracted from the Sync or Delay\_Request PTP message transit time to accurately measure the actual CF error.

The CF error is determined by subtracting the value of the correction field contained in the Sync or Delay\_Request PTP message header from the CF measured by the Ixia IP performance tester.

The CF error is calculated as follows:

$t_1$ : time when the Sync PTP message left the Ixia IP performance tester GMC port

$t_2$ : time when the Sync PTP message arrived at the Ixia IP performance tester SC port

or

$t_3$ : time when the Delay\_Request PTP message left the Ixia IP performance tester SC port

$t_4$ : time when the Delay\_Request PTP message arrived at the Ixia IP performance tester GMC port

Calibration = Internal Ixia IP performance tester delay + cable delays

Note: delay cable delay = 5.48 ns/m for copper or 3.29 ns/m for fiber

CF error =  $(t_2 - t_1 - \text{Calibration}) - \text{TC residence time}$

or

CF error =  $(t_4 - t_3 - \text{Calibration}) - \text{TC residence time}$

A positive value CF error indicates the residence time calculated by the TC is too short and a negative CF error indicates the calculated residence time was too long.

The CF error test can also be modified by increasing the Sync and Delay\_Request PTP message rate, using different TC ports, adding data-plane (user) traffic, adding control-plane traffic (i.e. running a protocol such Spanning Tree Protocol in addition to PTP), or repeating the test in multicast or unicast mode.

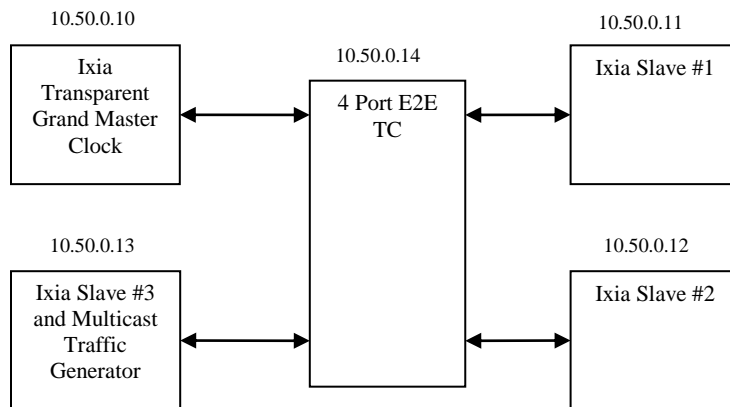

Figure 4. Correction Factor Error Test.

## IEEE 1588-2008 PERFORMANCE TEST RESULTS

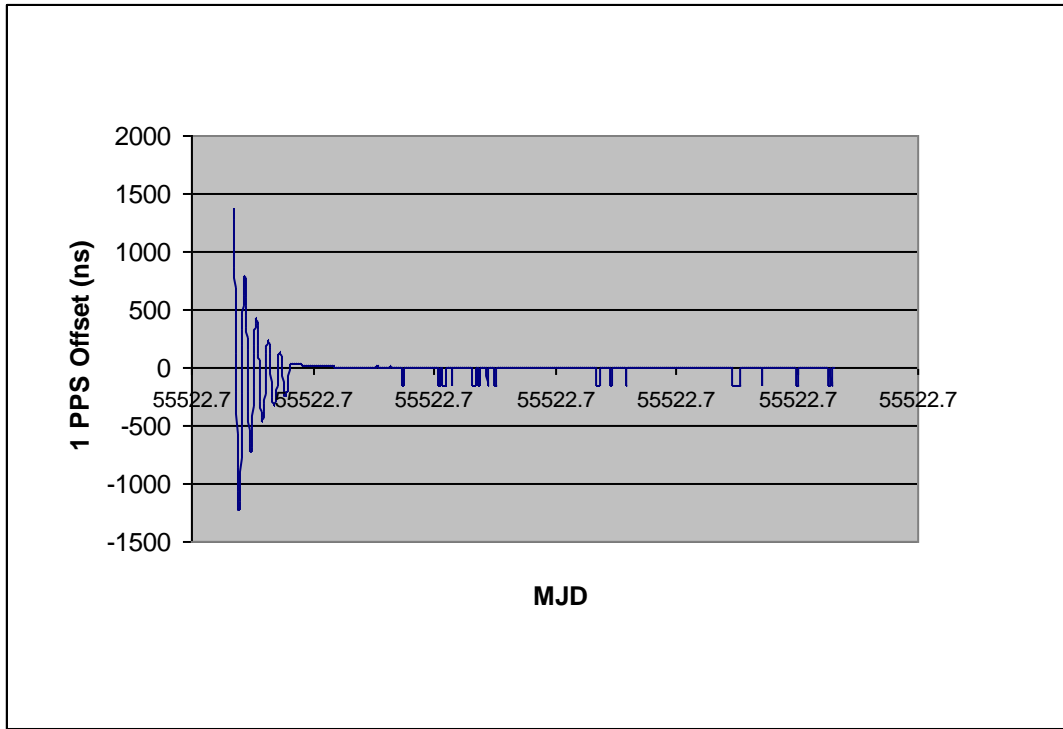

Figure 5. GMC to SC Switch Free Direct Time Transfer Test (Fiber).

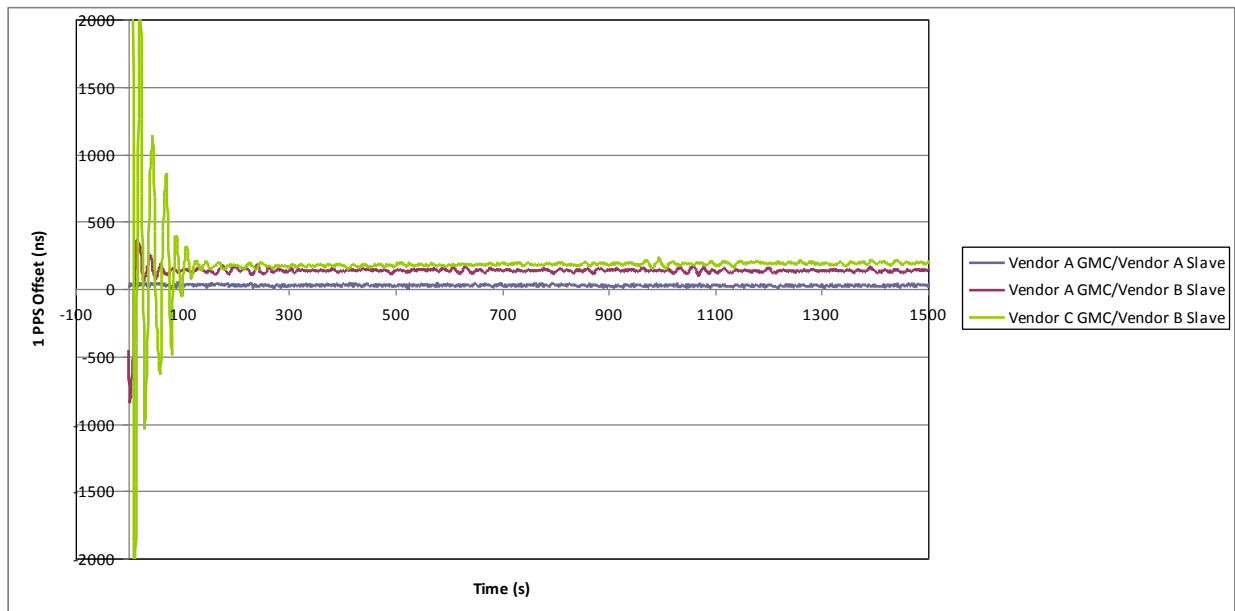

Figure 6. GMC to SC Switch Free Direct Time Transfer Test (Including Transient Response).

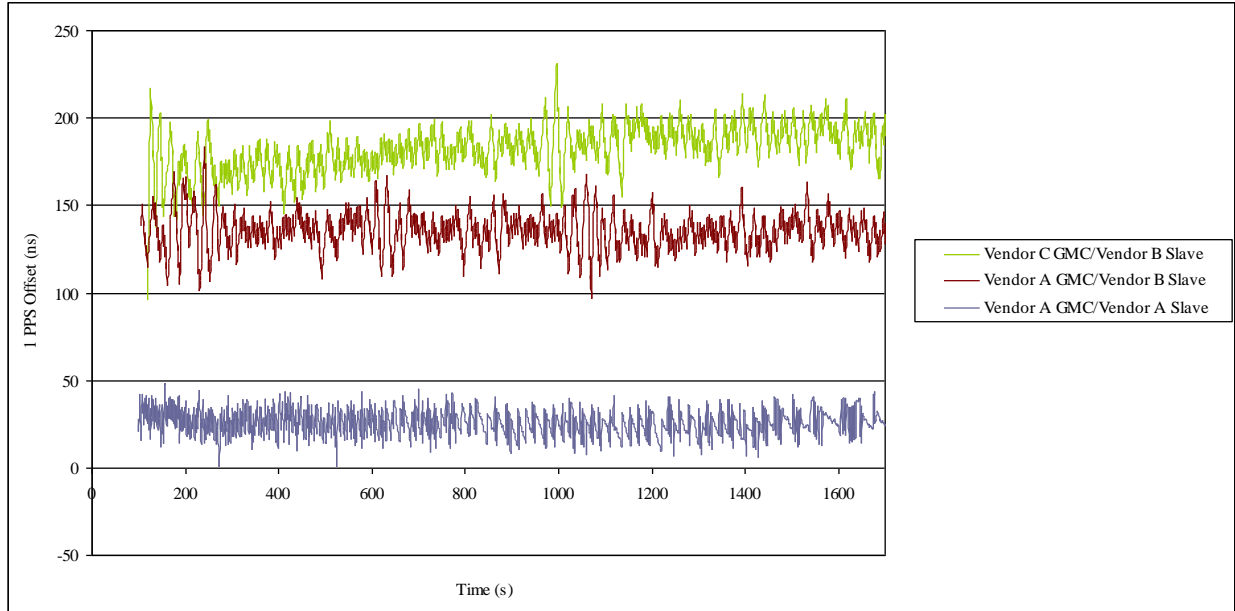

Figure 7. GMC to SC Switch Free Direct Time Transfer Test (Steady State Response Only).

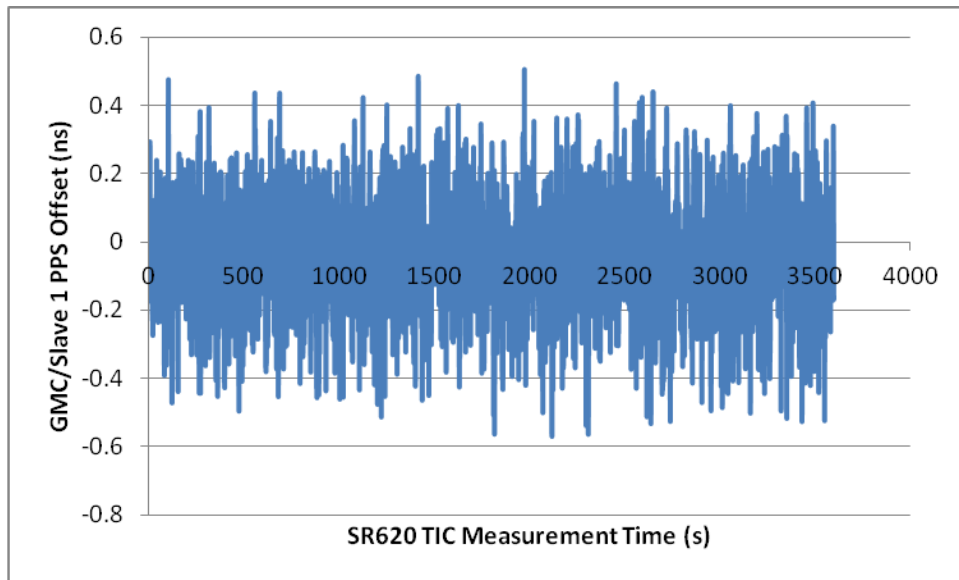

Figure 8. GMC to SC Switch Free Direct Time Transfer Test (Fiber).



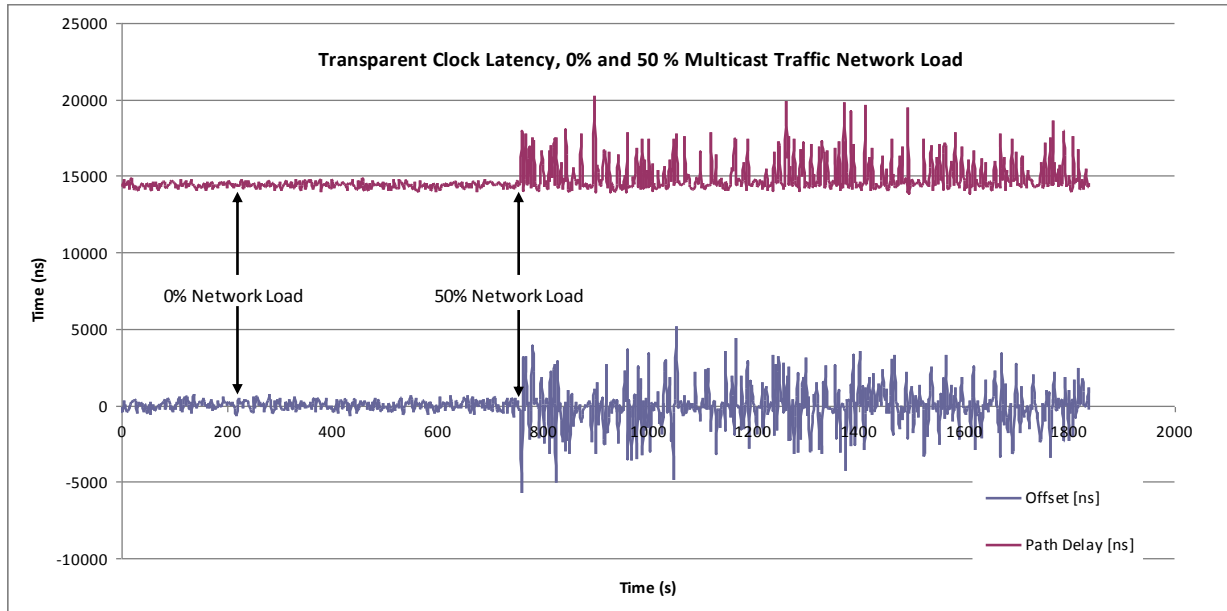

Figure 9. GMC to SC Switch Time Transfer Test through an End-to-End TC With and Without Network Loading.

## SOLUTIONS TO HIGH ACCURACY TIME TRANSFER USING IEEE 1588-2008 PTP

High accuracy time transfer ( $< 1$  ns) using commercially available PTP devices is very difficult even in a carefully controlled lab environment. A time transfer accuracy of less than 1 ns was possible only when the GMC was connected directly to a SC with a 3m crossover and the synchronization interval was set to  $1/256$  sec. The plot in (see Figure 8) shows the GMC 1 PPS output to SC 1 PPS output TIE data for an hour test run.

As mentioned earlier, solutions to PTP nano-second time transfer accuracy have been investigated in several research papers. Some of these solutions are fairly obvious such as “flattening” network topologies, using point-to-point PTP systems, using highly stable oscillators, time stamping PTP packets close to the Ethernet wire, optimizing SC servo loop response, and compensating for PHY and transmission media path delay asymmetries.

A National Semiconductor application note [4] discusses a clever solution to improve the time transfer accuracy of PTP. The application note claims the master to slave clock synchronization in a point-to-point PTP system can be improved 100 times if PTP is combined with Synchronous Ethernet (SyncE). The application note includes experimental data showing a master to slave frequency synchronization precision of 100 ps with a peak-to-peak measurement of less than 1 ns when the DP83640 IEEE 1588 PTP Transceiver (PHYTER) SyncE mode is enabled. The National Semiconductor DP83640 PHYTER achieves sub-nanosecond time transfer accuracy through physical-layer timing and packet-based timing.

The DP83640 PHYTER uses physical-layer timing for frequency synchronization (syntonization) and packet-based timing (arrival of PTP Sync messages) for time and phase synchronization. Physical layer-

timing is immune to packet delay variation which makes it better for frequency transfer than packet-based timing.

Another possible solution to using PTP for high accuracy time transfer is to develop a PTP profile for high accuracy time transfer. The International Telecommunications Union Telecommunications Standardization Sector (ITU-T) Study Group 15, Question (SG15Q13) has already completed work on a telecommunications PTP profile for frequency synchronization (Recommendation G.8265.1). The SG15Q13 is currently working on another telecommunications PTP profile for phase and time transfer (Recommendation G.8275.1) which may be suitable for high accuracy time transfer.

Achieving nano-second time transfer using PTP will require overcoming many technical hurdles. Commercial considerations can't be ignored either. There must be a sufficient market demand for PTP device vendors to produce PTP devices with nano-second time transfer accuracy. One micro-second time transfer, for the time being, is sufficient for most applications.

## REFERENCES

- [1] J. Burch, K. Green, J. Nakulski, and D. Vook, 2009, "Verifying the Performance of Transparent Clocks in PTP Systems," in International IEEE Symposium on Precision Clock Synchronization for Measurement, Control and Communication (ISPCS 2009), 12-16 October 2009, Brescia, Italy, pp. 1-6.
- [2] P. Loschmidt, R. Excel, A. Nagy, and G. Gaderer, 2008, "Limits of Synchronization Accuracy Using Hardware Support in IEEE 1588," in International IEEE Symposium on Precision Clock Synchronization for Measurement, Control and Communication (ISPCS 2008), 22-26 September 2008, Ann Arbor, Michigan, pp. 12-16.
- [3] R. Exel, G. Gaderer, and N. Kerö, 2010, "Physical Layer Ethernet Clock Synchronization," in 42<sup>nd</sup> Annual Precise Time and Time Interval (PTTI) Meeting, 15-18 November 2010, Reston, Virginia, pp. 77-88.
- [4] D. Miller, 2007, "DP83640 Synchronous Ethernet Mode: Achieving sub-nanosecond accuracy in PTP application," National Semiconductor Application Note 1730, September 2007.