

# FREQUENCY TRANSFER SYSTEM USING AN URBAN FIBER LINK FOR DIRECT COMPARISON OF SR OPTICAL LATTICE CLOCKS

Motohiro Kumagai, Miho Fujieda, Hirokazu Hachisu, Shigeo Nagano,  
A. Yamaguchi, Clayton R. Locke, and Testuya Ido

National Institute of Information and Communications Technology,  
4-2-1 Nukui-Kitamachi, Koganei, Tokyo 184-8795, Japan  
E-mail: *mkumagai@nict.go.jp*

## Abstract

*NICT in Japan has developed an all-optical link based on an optical carrier transfer system for direct comparison of two distant optical clocks. The frequencies of two Sr optical lattice clocks independently developed at NICT and the University of Tokyo were directly compared using this system and their consistency was confirmed at the 10<sup>-16</sup> level.*

## INTRODUCTION

Comparison between frequency standards is essential if their performance reproducibility is to be evaluated. In the past twenty years, satellite links such as GPS time transfer or two-way satellite time and frequency transfer (TWSTFT) have been used in the comparison of microwave atomic clocks [1]. To date, the frequency instabilities of GPS precise point positioning and TWSTFT are  $1 \times 10^{-15}$  and  $2 \times 10^{-15}$  respectively for an averaging time of five days. However, optical frequency standards have progressed significantly and now realize an extremely low level of short-term fractional frequency instability of  $1 \times 10^{-16}$  at an averaging time of 1000 seconds [2]. As the performance of optical clocks is far superior to that of today's satellite link, new technological developments are required for effective remote comparison. Stable transfer of a 1.5 $\mu$ m optical carrier using a fiber link is becoming one of the most promising methods to realize high stability transfer as demonstrated in several experiments [3-10].

Optical clocks based on strontium atoms confined in an optical lattice potential are considered one of the strong candidates for the future redefinition of the SI second [11-15]. As the clock transition lies in the visible region (698nm), both wavelength conversion to a 1.5 $\mu$ m optical carrier and a stable frequency transfer link are required for direct comparison of these state-of-the-art clocks. We have developed an all-optical link including wavelength converters, optical carrier transfer, and also an active polarization stabilizer (the latter being an essential item to be addressed for reliable long time measurement.). Operation of this all-optical link system has been demonstrated through research collaboration with the University of Tokyo (UT) fiber-linked to the National Institute of Information and Communications Technology (NICT) via a 60-km urban fiber link, where <sup>87</sup>Sr optical lattice clocks developed at both sites were compared. In this paper the details of the overall system and its performance are presented.

## ALL OPTICAL LINK SYSTEM BASED ON OPTICAL CARRIER TRANSFER

Figure 1 illustrates a schematic diagram of the frequency comparison. The clock signal at NICT is optically transferred to UT using an urban fiber link in Tokyo. At NICT, a Ti:sapphire-based optical frequency comb is phase-locked to a 698nm clock laser which itself is stabilized to the clock transition of strontium atoms. A 1.5 $\mu$ m telecom laser is stabilized to the optical frequency comb using a frequency-doubler and then is transmitted to UT via the urban fiber link. Fiber noise is suppressed by an optical carrier transfer system. Upon reaching the UT laboratory, the transferred light is then frequency doubled and phase locked to a second Ti:sapphire-based optical frequency comb. Another 698nm clock laser is stabilized to the strontium atoms in the UT lattice clock and a beatnote between this and the nearest tooth of the comb (which has the information of the NICT clock laser state) yields the frequency difference of two distant clocks. During the comparison process the optical fiber core deforms due to temperature and pressure variations, leading to a constantly changing state of polarization (SOP) of the transferred light. Stable frequency transfer requires not only compensation of a huge amount of phase noise but also active polarization control. In our system we have installed an automatic SOP stabilizer at UT.

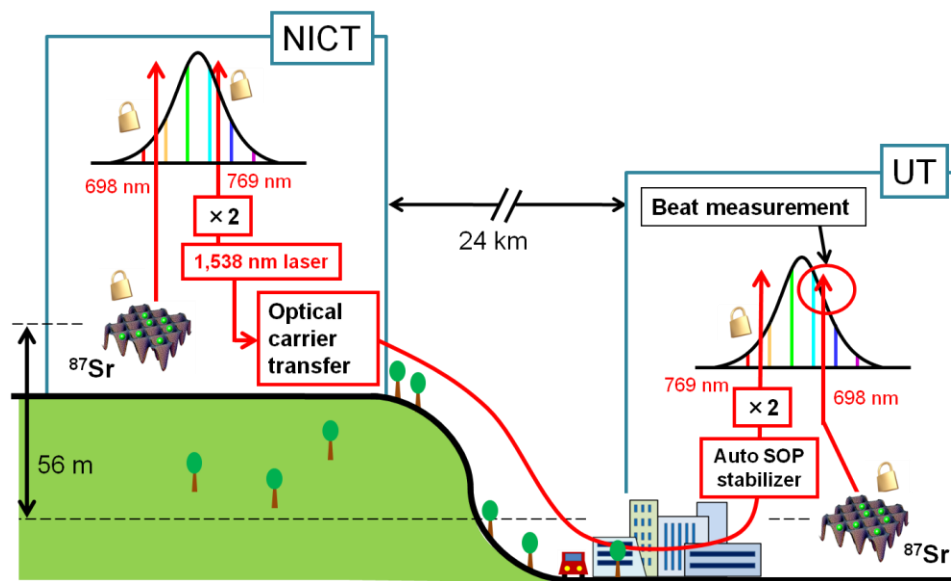

Figure 1. A schematic diagram of the optical frequency comparison between two distant lattice clocks developed at NICT and UT. Two campuses with differential elevation of 56 m are linked by a 60-km-long optical fiber.

### TOKYO URBAN FIBER LINK

NICT utilizes an optical fiber network test bed named JGN (Japan Gigabit Network), as an infrastructure for research and development on information and communications technology [16]. Part of the test bed connects NICT and Otemachi (a business district in Tokyo) by interconnecting several sections of single-mode dark fiber. The total link length is 45km and the optical loss is -15dB. To characterize the fiber noise cancellation system, we connect two parallel links to form a 90km round-trip link. For direct comparison of two optical clocks developed at NICT and UT, the fiber link is extended to UT using a 15km fiber link at Otemachi station. This additional link has relatively high optical loss (-15 dB) due to the use of

multiple fiber connectors. Although the physical distance between the two laboratories NICT and UT is only 24 km, the total fiber length is 60km and the total optical loss is -30dB, which is the same as that of the 90km round-trip link. The phase noise imposed on the optical carrier in the 45km link is much larger than that of the 15km link due to it being wired in the air where it is exposed to large temperature and pressure variations.

## OPTICAL CARRIER TRANSFER SYSTEM

Figure 2 shows the schematic diagram of the optical carrier transfer system. We have developed a noise cancellation system based on a fiber interferometer to compensate for the accumulated phase noise during the transition. The concept is similar to the scheme demonstrated by Ma *et al.*[6]. A narrow-bandwidth external-cavity diode laser at 1.5  $\mu\text{m}$  for transmission is coupled to a fiber-pigtailed acousto-optic modulator 1 (AOM1) driven by a 100-MHz voltage controlled oscillator (VCO) through an optical circulator 1 (OC1) and transferred to UT through the Tokyo urban fiber link. The transferred light is connected to the second fiber-pigtailed AOM 2 (AOM2) driven by a 55-MHz stable reference and amplified by a uni-directional erbium doped fiber amplifier 2 (EDFA2) through optical circulator 2 (OC2) at UT. Part of the output of the EDFA2 is fed to the frequency measurement system and the rest is returned to NICT through OC2 and AOM2. AOM2 works to differentiate the returned signal from stray reflections at connectors and splices. The returned light to NICT is coupled to a photo detector (PD) via AOM1 and OC1. The frequency of the returned light which passes AOM1 and AOM2 twice is shifted by -90 MHz, as AOM1 and AOM2 uses -1st and +1st diffraction order, respectively. The obtained beat signal is divided-by-50 to 1.8 MHz using a direct digital synthesizer (DDS). The DDS works not only to expand the capture range of the phase lock for handling the huge amount of phase noise but also makes the amplitude of the beat signal uniform. The resulting signal is mixed with a 1.8-MHz stable reference linked to a hydrogen maser. The mixer output is amplified, filtered, and fed back to the VCO. Thus, the phase of the VCO is adjusted to compensate the fiber induced noise. Normally, bi-directional EDFAs and Faraday rotator mirrors are used instead of a unidirectional EDFA to compensate for optical loss and to reflect part of the transferred light back to the local site. However, in our case when a bidirectional EDFA at UT was used unwanted back-reflections appeared from many SC/PC connectors at UT. This induced excessive input to the bidirectional EDFA, resulting in distortion of the output light. Although half of the noise induced by EDFA2 remains in our system an independent evaluation of instability of the EDFA2 reveals that it does not limit the performance of our system thus far.

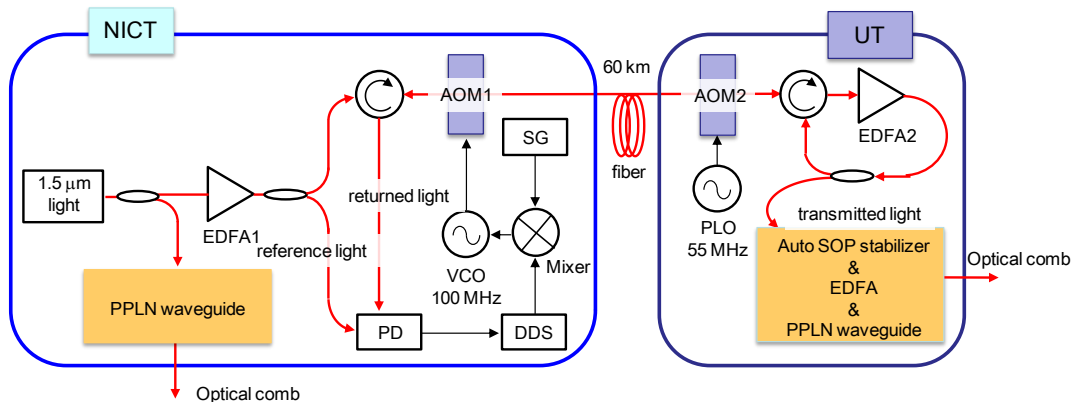

Figure 2. A schematic diagram of the optical carrier transfer system. The system consists of NICT and UT sites. OC: optical circulator, AOM: acousto-optic modulator, VCO: voltage controlled oscillator, SG: signal generator, DDS: direct digital synthesizer, PD: photo detector, PLO: phase locked oscillator, EDFA: erbium doped fiber amplifier.

To evaluate the optical carrier transfer system the 1.5 $\mu$ m transmitted light is compared with the 1.5 $\mu$ m reference light after undergoing a 90km roundtrip urban link. The phase noise of the transmitted light with respect to the reference light is shown in Figure 3. The blue and red curves show results with and without link stabilization, respectively. The delay of propagation limits the servo loop bandwidth, which constrains the loop gain of the servo. The theoretical maximum of noise suppression is  $1/3(2\pi f\tau)^2$  [4], where  $f$  is the Fourier frequency and  $\tau$  is the one-way propagation time. In our case, the maximum noise suppression is 56 dB in the 90km link at a Fourier frequency of 1 Hz.

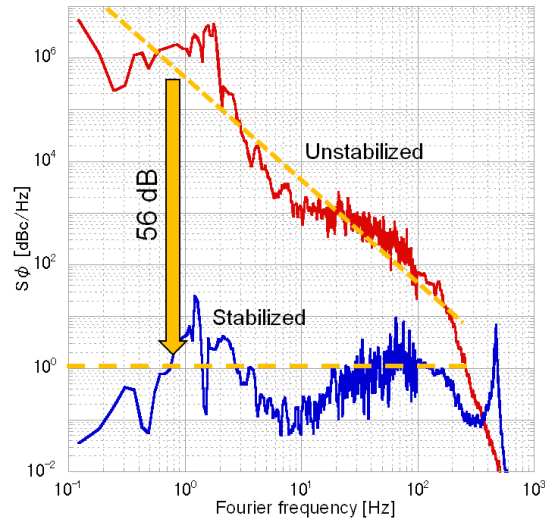

Figure 3. Phase noise of the transmitted light in the 90-km round trip link. The difference of 56 dB at 1 Hz agrees with the theoretical limit of phase noise suppression.

Figure 4 depicts the frequency stability of the transmitted light and shows the achieved noise rejection factor reaches the theoretical limit. Shown on the plot are results obtained with a  $\Pi$ -type counter (green) as well as with a  $\Lambda$ -type counter (blue), with discrepancies that may be attributed to the measurement bandwidth of each frequency counter. Also shown on the plot are the large difference in transfer stabilities when measurements are made between 15:00 to 17:00 (day time) shown as dashed lines, and from 1:00 to 3:00 (night time) shown as solid lines.

In spite of the huge phase noise in the Tokyo urban fiber link [17,18], the transfer stability of measurements made at night time reached  $4 \times 10^{-18}$  for an averaging time of 1000 seconds [19]. As mentioned above, the phase noise of 45km NICT-Otemachi link is larger than that of 15km Otemachi-UT link. Therefore, the phase noise of the 60-km NICT-UT link is no larger than that of the 90km roundtrip link, and thus the achieved transfer stability in the 90km link can be treated as the upper limit of the achievable transfer stability in the 60-km NICT-UT link.

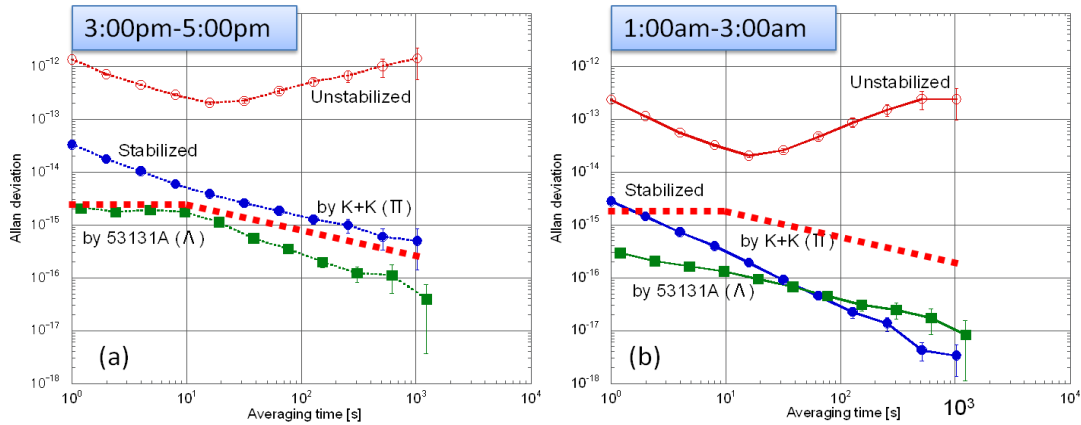

Figure 4. Frequency instabilities of the transmitted light in the unstabilized (hollow circles) link and stabilized (squares and filled circles) links. The frequency instabilities shown in (a) and (b) were measured during the daytime (3:00pm-5:00 pm) and around midnight (1:00 am-3:00 am), respectively. The dashed lines show the instability of a typical optical lattice clock.

## ACTIVE POLARIZATION STABILIZER AND RELIABLE MEASUREMENT

The conversion efficiency of PPLN is quite sensitive to the SOP of the input light. Hence, active polarization control is essential for uninterrupted, reliable measurements. An automatic polarization control system based on a commercial polarization tracker is installed at UT. The RF amplitude of the beat signal between the SHG light and frequency comb is monitored in the control loop that keeps the polarization of the input light to the PPLN constant. The tracking speed is  $47\pi/s$ , and the typical SOP recovery time is 0.7 ms. The automatic polarization system significantly reduced the intensity fluctuations of the beat signal to within 2 dB for 16 hours. This novel system is thus capable of continuous operation without manual polarization adjustments and it does not limit the performance of the transfer system. Even though the SOP is effectively stabilized by our polarization control system, small intensity fluctuations remain. If an intensity fluctuating signal was sent to the frequency counter, it might induce incorrect readouts in the frequency measurement. To avoid such a frequency miscount, the Ti:S frequency comb at UT is phase-locked to the SHG light, and the in-loop beat signal between the transmitted signal and the Ti:S frequency comb is counted to confirm a stable phase lock. The system is robust and the stable intensity of the final beat signal between the frequency comb and the clock laser at UT yields a reliable frequency count. For comparison of visible and  $1.5\mu\text{m}$  light without performance degradation the transfer stabilities of bridging components should be lower than the fractional instability of the optical clock. The most critical component is the EDFA. We have confirmed that the transfer stability of the EDFA is lower than that of current instability of the optical clocks by independent measurements. In addition, the Ti:S frequency combs at both sites and the ECDL at the local site are tightly phase-locked to the reference light, and their instabilities are negligibly small.

## STRONTIUM-87 OPTICAL LATTICE CLOCKS AT NICT AND UT

The optical lattice clocks based on spin-polarized  $^{87}\text{Sr}$  atoms at NICT and UT were developed separately. Two laser-cooling stages are employed; in the first stage, the atoms are preliminary cooled using the 461 nm broad transition with a natural linewidth of 32 MHz. After that they are further cooled to about  $3\mu\text{K}$  using the 689nm inter-combination transition with the natural linewidth of 7.4 kHz. An ensemble of

roughly  $10^4$  cooled atoms is loaded into vertically oriented and linearly polarized one-dimensional optical lattice potentials. After optically pumping to one of the stretched magnetic sublevels, either  $m_F = +9/2$  or  $m_F = -9/2$ , the  $5s2\ ^1S_0(F = 9/2, m_F = \pm 9/2) - 5s5p\ ^3P_0(F = 9/2, m_F = \pm 9/2)$  transition is probed by a clock laser propagating along the strong confinement axis of the lattice to suppress the Doppler and recoil shifts. This clock transition exists at 698nm. By probing both sides of the lineshape at its full width at half maximum, the deviation of the clock laser frequency from the atomic resonance is detected and used for clock stabilization. The clock transition at UT is observed with Fourier-limited linewidth of 4 Hz for 200 ms interrogation time in a clock cycle time of 1.5 s, wherein atoms are loaded into the lattice and one side of the magnetic sublevels ( $m_F = \pm 9/2$ ) is probed. At NICT the clock transition is observed with Fourier-limited linewidth of 20Hz with a clock cycle time of 1.3s. The systematic frequency correction in each clock is independently evaluated. In this paper detailed evaluation is omitted, for details see [20, 21]. Each systematic frequency shift and their uncertainty budgets are summarized in Table 1. The overall systematic frequency shift of the frequency difference amounts to 3.66 (31) Hz and the largest contributor is gravitational red shift.

Table 1. Systematic frequency shifts and their uncertainties for each  $^{87}\text{Sr}$  optical lattice clock at UT and NICT

contributor	UT		NICT	
	Correction	Uncertainty	Correction	Uncertainty
AC Stark -Lattice	0.19	0.10	0.10	0.10
AC Stark -Probe	0.00	0.00	0.01	0.01
BBR	2.17	0.10	2.26	0.10
2nd Zeeman	1.24	0.10	0.23	0.10
Gravitational shift	-0.95	0.09	-3.57	0.05
Collision	0.00	0.10	-0.04	0.12
Servo error	0.00	0.01	0.00	0.01
Total	2.65	0.22	-1.01	0.22

## DIRECT FREQUENCY COMPARISON OF TWO DISTANT OPTICAL LATTICE CLOCKS

Two distant optical lattice clocks at NICT and UT were compared using an all optical link based on optical carrier transfer, optical frequency combs, frequency doublers and polarization stabilizers. Figure 5 shows the time record of the beat signal. Thanks to the highly stable optical link, a Hz-level frequency difference between distant  $^{87}\text{Sr}$  optical lattice clocks is clearly visible over the time scale of minutes. The observed frequency difference is attributed to different systematic shifts of the two clocks as listed in Table 1. The largest contributor to the frequency offset between the two clocks is the gravitational red shift of 2.62 Hz. This result demonstrates that the two distant Sr lattice clocks generate the same frequency within a systematic uncertainty of 0.31 Hz ( $7.3 \times 10^{-16}$  fractionally) for the 429 THz clock frequency.

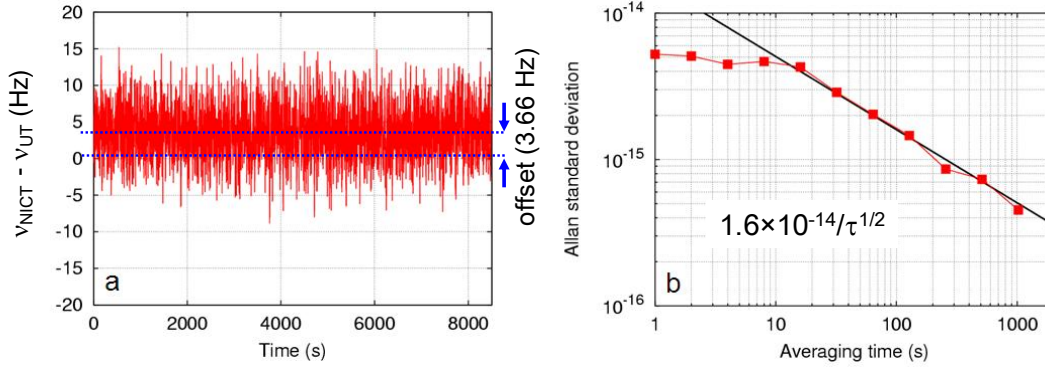

Figure 5. Frequency comparison of two distant optical lattice clocks at NICT and UT. (a) Real-time observation of the frequency difference obtained by the beat measurement at UT. The frequency difference caused by differential systematic shifts between the two clocks (3.68 Hz) is clearly observable. (b) The relative instability of the clock comparison is shown as a function of averaging time. The obtained instability is measured to be  $1.6 \times 10^{-14} / \tau^{1/2}$ , which is mainly dominated by the Dick-effect-limited instability of NICT optical lattice clock.

The relative instability of the frequency comparison is measured to be  $1.6 \times 10^{-14} / \tau^{1/2}$  as shown in Figure 5(b). The intrinsic noise of the clock laser and the dead time in the clock cycle cause aliasing noise that is referred to as the Dick effect [22]. The Dick-effect-limited instability at 1 second is expected to be  $6 \times 10^{-15}$  at UT and  $1.5 \times 10^{-14}$  at NICT. These instabilities are consistent with the result shown in Figure 5(b). This remote comparison system, therefore, allows us to investigate the relative instabilities of distant Sr optical lattice clocks. A fractional instability at averaging time of 1000 s reached  $5 \times 10^{-16}$ , which indicates more than two orders of magnitude improvement over the remote comparison via the best current satellite-based microwave link.

## SUMMARY

We established an all-optical link for direct comparison of two distant optical clocks developed at NICT and UT. In the experiment using a 90km urban fiber link, a  $1.5 \mu\text{m}$  optical carrier transfer system realizes transfer stability of  $2 \times 10^{-15}$  at 1 second and  $4 \times 10^{-18}$  at 1000 seconds. To compare two 698nm clock lasers, we assembled an all-optical link consisting of an optical carrier transfer system, optical frequency combs and frequency doublers. A polarization control system for the transmitted light was developed to stabilize the intensity of second harmonic light, enabling reliable long-term measurements. Furthermore we have demonstrated for the first time that distant optical clocks generate the same frequency within a systematic uncertainty of 0.31Hz for 429 THz carrier frequency using an all-optical link. The frequency instability of two distant clocks was  $1.6 \times 10^{-14} / \tau^{1/2}$ , which was not limited by the overall instability of the all-optical link.

The short-term stability of optical clocks is improving day by day. When such stable optical clocks are to be compared, we should use a tracking laser working as a low noise high gain amplifier instead of the unidirectional EDFA employed in the current setup. Moreover, an optical fiber link having less intrinsic noise would facilitate a more stable transfer.

## ACKNOWLEDGEMENTS

The authors would like to thank Tetsushi Takano, Masao Takamoto and Hidetoshi Katori at the University of Tokyo for their operation of the <sup>87</sup>Sr clock and fruitful cooperation and Kazuhiko Nakamura at NICT for his support on the usage of the JGN optical fiber link. This work was supported by the JST and JSPS through CREST and FIRST programs, respectively.

## REFERENCES

- [1] A. Bauch, J. Achkar, S. Bize, D. Calonico, R. Dach, R. Hlavac, L. Lorini, T. Parker, G. Petit, D. Piester, K. Szymaniec, and P. Urich, 2006, “*Comparison between frequency standards in Europe and the USA at the  $10^{-15}$  uncertainty level,*” **Metrologia**, **Vol. 43**, 109.
- [2] C. W. Chou, D. B. Hume, J. C. J. Koelemeiji, D. J. Wineland, and T. Rosenband, 2010, “*Frequency comparison of two high-accuracy Al<sup>+</sup> optical clocks,*” **Phys. Rev. Lett.**, **Vol. 104**, 070802.
- [3] S. M. Foreman, K. W. Holman, D. D. Hudson, D. J. Jones, and J. Ye, 2007, “*Remote transfer of ultrastable frequency references via fiber networks,*” **Rev. Sci. Instrum.**, **Vol. 78**, 021101.
- [4] P. A. Williams, W. C. Swann, and N. R. Newbury, 2008, “*High-stability transfer of an optical frequency over long fiber-optic links,*” **J. Opt. Soc. Am. B**, **Vol. 25** (8), 1284–1293.
- [5] M. Musha, F.-L. Hong, K. Nakagawa, and K. Ueda, 2008, “*Coherent optical frequency transfer over 50-km physical distance using a 120-km-long installed telecom fiber network,*” **Opt. Express** **16** (21), 16459–16466.
- [6] L. S. Ma, P. Jungner, J. Ye, and J. L. Hall, 1994, “*Delivering the same optical frequency at two places: accurate cancellation of phase noise introduced by an optical fiber or other time-varying path,*” **Opt. Lett.**, **Vol. 19** (21), 1777–1779.
- [7] N. R. Newbury, P. A. Williams, and W. C. Swann, “*Coherent transfer of an optical carrier over 251 km,*” **Opt. Lett.**, **Vol. 32** (21), 3056–3058.
- [8] F. Kefelian, O. Lopez, H. Jiang, C. Chardonnet, A. Amy-Klein, and G. Santarelli, 2009, “*High-resolution optical frequency dissemination on a telecommunications network with data traffic,*” **Opt. Lett.**, **Vol. 34** (10), 1573–1575.
- [9] O. Lopez, A. Haboucha, F. Kefelian, H. Jiang, B. Chanteau, V. Roncin, C. Chardonnet, A. Amy-Klein, and G. Santarelli, 2010, “*Cascaded multiplexed optical link on a telecommunication network for frequency dissemination,*” **Opt. Express**, **Vol. 18** (16), 16849–16857.
- [10] O. Terra, G. Grosche, and H. Schnatz, 2010, “*Brillouin amplification in phase coherent transfer of optical frequencies over 480 km fiber,*” **Opt. Express**, **Vol. 18** (15), 16102–16111.
- [11] M. Takamoto, F. L. Hong, R. Higashi, and H. Katori, 2005, “*An optical lattice clock,*” **Nature**, **Vol. 435**, 321.



- [12] G. K. Campbell, A. D. Ludlow, S. Blatt, J. W. Thomsen, M. J. Martin, M. H. G. de Miranda, T. Zelevinsky, M. M. Boyd, J. Ye, S. A. Diddams, T. P. Heavner, T. E. Parker, and S. R. Jefferts, 2008, “The absolute frequency of the 87Sr optical clock transition,” **Metrologia**, **Vol. 45**, 539.
- [13] X. Baillard, M. Fouche, R.L. Targat, P. G. Westergaard, A. Lecallier, F. Chapelet, M. Abgrall, G. D. Rovera, P. Laurent, P. Rosenbusch, S. Bize, G. Santarelli, A. Clairon, P. Lemonde, G. Grosche, B. Lipphardt, and H. Schnatz, 2008, “An optical lattice clock with spin-polarized 87Sr atoms,” **Eur. Phys. J. D**, **Vol. 48**, 11-17.
- [14] T. Akatsuka, M. Takamoto, and H. Katori, 2008, “Optical lattice clocks with non-interacting bosons and fermions,” **Nature Phys.**, **Vol. 4**, 954.
- [15] St. Falke, H. Schnatz, J. S. R. Vellore Winfried, Th. Middelman, St. Vogt, S. Weyers, B. Lipphardt, G. Grosche, F. Riehle, U. Sterr, and Ch. Lisdat, 2011, “The 87Sr optical frequency standard at PTB,” arXiv:1104.4850v1.
- [16] Japan Gigabit Network 2 plus [Online]. Available: [http://www.jgn.nict.go.jp/jgn2plus\\_archive/english/index.html](http://www.jgn.nict.go.jp/jgn2plus_archive/english/index.html).
- [17] M. Kumagai, M. Fujieda, S. Nagano, and M. Hosokawa, 2009, “Stable radio frequency transfer in 114 km urban optical fiber link,” **Opt. Lett.**, **Vol. 34** (19), 2949–2951.
- [18] M. Fujieda, M. Kumagai, and S. Nagano, 2010, “Coherent microwave transfer over a 204-km telecom fiber link by a cascaded system,” **IEEE Trans. Ultrason. Ferroelectr. Freq. Control**, **Vol. 57** (1), 168–174.
- [19] M. Fujieda, M. Kumagai, S. Nagano, A. Yamaguchi, H. Hachisu, and T. Ido, 2011, “All-optical link for direct comparison of distant optical clocks,” **Opt. Express**, **Vol. 19**, 16498.
- [20] M. Takamoto, T. Takano, and H. Katori, 2011, “Frequency comparison of optical lattice clocks beyond the Dick limit,” **Nature Photon.**, **Vol. 5**, 288.
- [21] A. Yamaguchi, M. Fujieda, M. Kumagai, H. Hachisu, S. Nagano, Y. Li, T. Ido, T. Takano, M. Takamoto, and H. Katori, 2011, “Direct comparison of distant optical lattice clocks at the  $10^{-16}$  uncertainty,” **Appl. Phys. Express**, **Vol. 4**, 082203.
- [22] G. Santarelli, C. Audoin, A. Makdissi, P. Laurent, G. J. Dick, and A. Clairon, 1998, “Frequency Stability Degradation of an Oscillator Slaved to a Periodically Interrogated Atomic Resonator,” **IEEE Trans. Ultrason. Ferroelectr. Freq. Control**, **Vol. 45**, 887.

