

# THE PERFORMANCE OF ULTRA-STABLE OSCILLATORS FOR THE GRAVITY RECOVERY AND INTERIOR LABORATORY (GRAIL)

Gregory Weaver  
Johns Hopkins University Applied Physics Laboratory  
Laurel, MD, USA  
*gregory.weaver@jhuapl.edu*

Jeffrey Garstecki and Samuel Reynolds  
Johns Hopkins University Applied Physics Laboratory

## Abstract

*In early 2010, JHU/APL delivered four ultra-stable oscillators (USOs) to the Jet Propulsion Laboratory (JPL) for the Gravity Recovery and Interior Laboratory (GRAIL) mission. GRAIL is a NASA Discovery lunar mission with the goals of mapping the entire lunar gravity field and, through the geodesy determined from this result, attempt to define the most likely model for the moon's deep interior.*

*Similar to its 2002 predecessor, the Gravity Recovery and Climate Experiment (GRACE), GRAIL will use two formation flying spacecraft with a dual one-way ranging instrument to measure the relative line-of-sight distance between the spacecraft. From these measurements, the relative velocity between the spacecraft can be determined and gravitational force computed. Unlike GRACE, GRAIL has no continuous GPS viewpoint. To compensate for this lack of a continuous positioning reference system, the two spacecraft of GRAIL will form a time transfer link, periodically assisted by ground mission operations.*

*The GRAIL time transfer link places an additional demand on the USO frequency stability requirements with a drift rate requirement of  $< 7E-11/day$ , nearly ten times better than the predecessor GRACE requirement. Along with achieving the drift rate, the delivered USOs showed Allan deviation of  $< 2 E-13$  at 10 and 100 second time intervals, with two units measuring in the 7 to 9  $E-14$  region of stability. Our paper will present these performance details for each of the delivered USO's and discuss the GRAIL USO requirements in the context of the emerging mission needs for both excellent short-term stability and low noise for metrology and long-term stability for assisting spacecraft navigation.*

## BACKGROUND

The Johns Hopkins University Applied Physics Laboratory (JHU/APL) has contributed to a legacy of space missions with its ultra-stable oscillator (USO) technology, as shown in the upper half of the timeline in Fig. 1. Coordinately, JHU/APL has implemented a series of product innovations, shown in the lower half of Fig. 1, which have enabled continuously escalating mission requirement for stability, size, mass, and power. The USOs delivered by JHU/APL for integration into the Jet Propulsion

Laboratory's (JPL) microwave ranging instrument of the Gravity Recovery and Interior Laboratory (GRAIL) are the latest in a series of NASA delivered products tracing their heritage back to the Cassini mission to provide radio science exploration of Saturn and its dominant moons, most notably Titan.

Under this heritage-based development paradigm, JHU/APL has met the demand for highest reliability while offering product improvements. Our design effort for the GRAIL USO was, therefore, carefully guided by the principle, "keep what works, apply best current practices, and mitigate obsolescence in parts and assembly." For the GRAIL program, the most relevant heritage for the USO design was the Gravity Recovery and Climate Experiment (GRACE) predecessor USOs built and launched in the early 2000s. The most immediate heritage was the New Horizon's USO built and launched in the mid-2000s for JHU/APL's exploration mission of Pluto and the Kuiper belt.

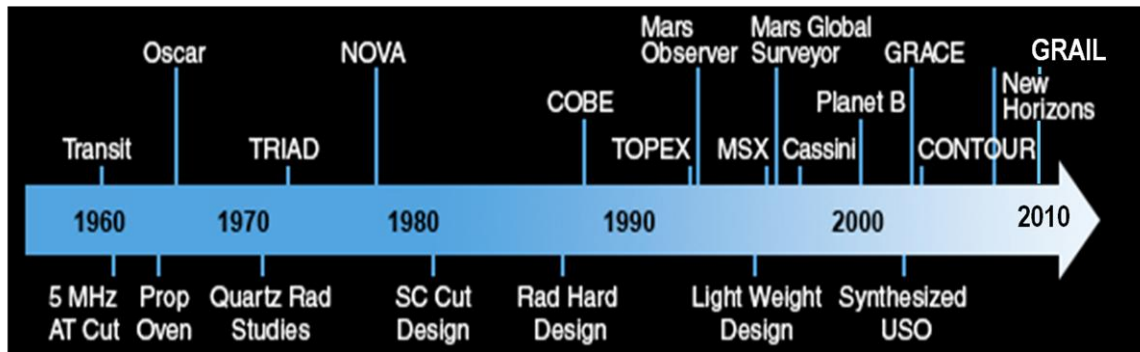

Fig. 1. Timeline of USO mission legacy with history of design innovations.

In fact, it was highly desired by the GRAIL program that the USO's function, design, and fabrication closely follow their GRACE predecessors to support the goal of high value science return for lunar exploration. As GRAIL is a NASA Discovery class mission, the selection criteria is weighted on the mission's low implementation risk and frugal approach to achieving its science objectives.

As the mission name describes, GRAIL will use gravity recovery to completely map the Moon's gravitational field. During its 90-day mission, GRAIL will use the relative position between two formation flying spacecraft, a lead and a follower, to extract variations in the Moon's gravity to an expected precision of  $5 \text{ E-6 g's}$ . From these measurements, the science of the Moon's surface and sub-surface structure will be advanced and our theoretical understanding of the Moon's progression to its current state will be improved. Maria Zuber of the Massachusetts Institute of Technology, GRAIL's Principal Investigator, anticipates the determination of the Moon's interior core dependent on the success of GRAIL's implementation and data collection [1].

As previously mentioned, GRAIL is an extension of the GRACE mission approach. Launched in 2002, GRACE continues to map the gravity field of the Earth and provides details of its hydrologic cycle [2]. The notable success of GRACE was a key influence for the selection of GRAIL by NASA. In this regard, the GRACE instrument architecture and mission design was highly leveraged for GRAIL, except for several important differences related to the operational environments between the Earth and the Moon.

GRACE is a low flying tandem formation of satellites orbiting in a polar orientation at 500 km above the Earth. At this altitude, GRACE must contend with drag from the Earth's atmosphere and uses accelerometers to compensate for these non-gravitational forces. GRAIL will not experience such forces

and will not use any on-board inertial measurement system. The low altitude orbit of GRACE allows the satellite formation to use GPS as a tracking augmentation for orbit determination and time transfer for relative frequency correction between the USOs on each satellite. Since GPS is not reliable at the Moon, GRAIL includes a two-way time transfer link between the spacecraft and an X-band ranging beacon for Doppler tracking back to the NASA Deep Space Network (DSN) for these purposes.

Figure 2 is a depiction of the signaling scheme that will be used in the GRAIL mission for navigation and communication. Two Ka-band (32 GHz) carrier-phase tracking loops, one in each spacecraft at slightly offset frequencies, are used for inter-satellite distance determination. The quality of combining the slightly delayed received signal with the incident transmitted signal on each satellite forms an exchange of phase information that can then be processed into relative motion observables between the satellites. Also, the combining process creates the effect of a high-pass noise cancelling filter on the errors introduced by the local USO's, proportional to the light-time propagation between the satellites. In this manner, the JPL microwave instrument of GRAIL is known as a dual one-way range (DOWR) measurement system, described extensively for GRACE in [3].

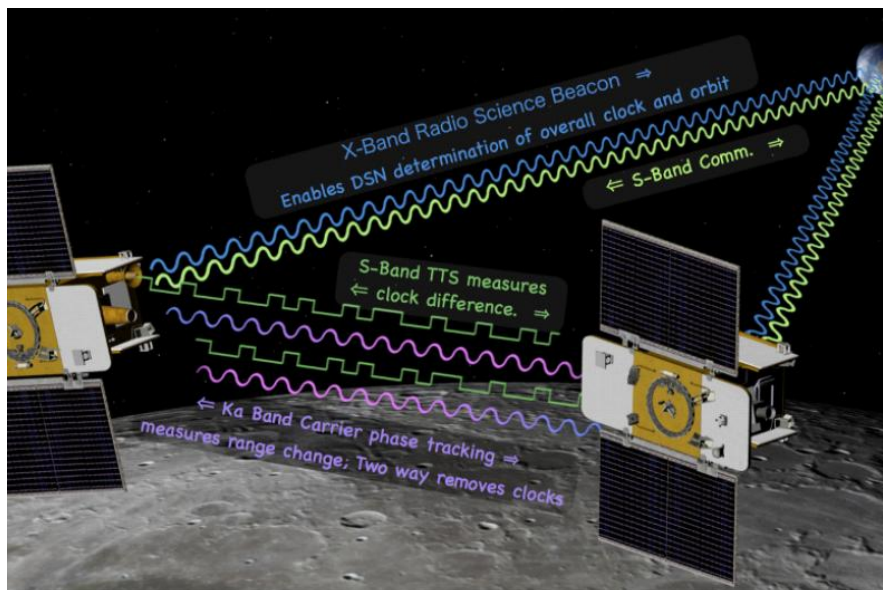

Fig. 2. GRAIL signaling scheme during DSN observation, also Fig. 1 of [4].

The quality of DOWR measurement relies on both critical timing and frequency performance characteristics. Extremely low phase noise or short-term frequency stability is required from the local frequency sources that feed the microwave links. Optimally, the noise performance of the two sources should be minimized in the region of a few seconds to several minutes to accommodate the time-of-flight passage of the tandem satellite formation over any expected mass concentrations or other physical anomalies associated with the gravity variation of the Moon. Science-grade USOs, such as produced by JHU/APL, offer this critical frequency stability performance in the order of  $< 2 \text{ E-13}$  over 10 to 1000 s. For GRAIL, this performance translates on the 32 GHz carrier-phase tracking loops to about 70  $\mu\text{cycles}$  per  $\text{Hz}^{-1/2}$  or about 64 microns in precision uncertainty [4]. Still, USOs are based on quartz resonators and present frequency offsets (rate errors) and frequency drift (aging), which affect accuracy to the critical timing required to coordinate the time tagging of the phase measurements and allow observable extraction.

In GRACE, as previously mentioned, common-view GPS timing is recovered from dual frequency P-code carrier-phase and pseudo-range measurements made by the on-board receivers on each satellite. These data are then sent to the mission ground support stations for post-processing into the precise orbit determination of each satellite, estimated to within 2 cm. Coordinately, since each on-board GPS receiver is also driven by the USO of the DOWR instrument, highly accurate frequency correction can then be made to the phase measurement data, aligning the absolute time-tagging to achieve near simultaneous sampling of less than 0.1 ns within the tandem satellite system [5]. GRAIL cannot use GPS receivers for this critical function of frequency correction and, therefore, requires the innovation of an additional S-band time transfer system (TTS).

Referring to Fig. 2, the TTS measures the relative clock difference produced by the USOs between each GRAIL satellite. This function is coupled with the absolute frequency difference determined in each satellite through Doppler measurements on the X-band radio science beacons, referenced against the highly accurate station clocks of the DSN, to create a clock correcting capability of better than 100 ns [4]. The S-band telecom system can also be used for this USO frequency determination. In a similar manner to GRACE, clock correction of the time-tagged phase data is then performed using post-processing. Nonetheless, the GRAIL mission design necessarily must sometimes contend with nearly 3500 s of obscured phase data collection resulting from the 113-minute circular orbit of the science phase of the mission. Moreover, the available DSN coverage for the mission is constrained to about 16 hours, leaving 8 hours of undetermined USO performance.

## DEMANDS FOR USO PERFORMANCE

These gaps in systemic coverage of clock performance offer unique challenges to the DOWR microwave instruments and USOs of GRAIL. Functionally, the periodic gaps in GRAIL observation from the earth place a significant constraint on the frequency drift (aging) performance of the USO of  $< 7 \text{ E-11}$  per day or equivalently  $< 5 \text{ E-11}$  at 57600 s (8 hour), as measured by the Allan deviation. Table 1 shows a comparison of the critical USO performance specifications between GRACE, New Horizons, and GRAIL, which all share high design similarity and heritage.

The comparison of the New Horizons USO specifications to GRAIL in Table 1 has an additional relevance, beyond its design heritage, in that the USOs on board the spacecraft have similar roles; science collection enabled by the USO's low noise performance, support of the telecom system, and navigation augmentation through on-board frequency determination using Doppler referenced to the DSN [6].

As shown in Fig. 4, the New Horizons USOs supply the signal for a radio science experiment known as REX. REX will be used during the encounter with Pluto to determine a possible trace atmosphere, remnant from Pluto's most recent perihelion. The REX instrument will transfer radio waves during occultation through any constituent atmosphere of Pluto. From the Earth, the radio science method extracts phase changes on the USO referenced signal, which are then used to determine gas density and composition. Like GRAIL, the quality of the radio science data is directly influenced by the level of noise or short-term stability of the USO reference during the period of measurement. In the case of REX, this is the time in transit behind Pluto.

Table 1. Comparison of critical specifications for JHU/APL science-grade USO's.

Parameter	GRACE	New Horizons	GRAIL
Allan Deviation	$4 \times 10^{-12}$ (0.2 s) $2 \times 10^{-13}$ (2 s) $2 \times 10^{-13}$ (10 s) $3 \times 10^{-13}$ (100 s) $5 \times 10^{-13}$ (1000 s)	$\leq 3 \times 10^{-13}$ (1 s) $\leq 2 \times 10^{-13}$ (10 s) $\leq 3 \times 10^{-13}$ (100 s)	$\leq 3 \times 10^{-13}$ (1 s) $\leq 3 \times 10^{-13}$ (10 s) $\leq 3 \times 10^{-13}$ (100 s) $\leq 6 \times 10^{-13}$ (1000 s) $\leq 5 \times 10^{-11}$ (57600 s)
Daily Aging Rate	$5 \times 10^{-10}$ / 24 hours	$1 \times 10^{-10}$ / 24 hours	$7 \times 10^{-11}$ / 24 hours
Magnetic Coefficient:	$\leq 4 \times 10^{-13}$ / Gauss	$\leq 2 \times 10^{-12}$ / Gauss	No requirement
Temperature Coefficient:	$\leq 1 \times 10^{-12}$ / °C	$\leq 1 \times 10^{-12}$ / °C	$\leq 1 \times 10^{-12}$ / °C
Mass:	< 1.7 kg	< 1.5 kg	< 1.75 kg
Steady state power (vac)	<3.5-W	$\leq 3.5$ watts	$\leq 3.2$ watts
Performance Temp. Range	+10 C to 35 C	+20 C to 40 C	+10 C to +35 C

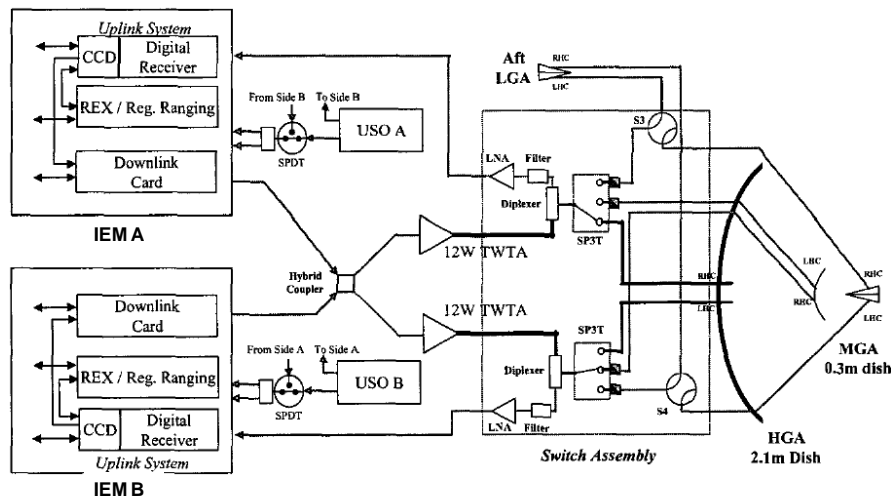

Fig. 4. NH RF system diagram showing USOs driving both REX and transceiver, also Fig. 3 of [6].

Also like GRAIL, New Horizons also takes advantage of the on-board USO to drive the digital transceiver communication system. A transceiver was chosen for New Horizons so that the uplink frequency acquisition function could operate independent of the downlink, thereby enabling the use of the downlink for REX. The utility of the transceiver approach allows the frequency difference between the uplink provided by the DSN and downlink determined by the USO to be measured and sent back in telemetry. This telemetry information is used in a novel navigation augmentation known as noncoherent

Doppler, effectively providing the capability of two-way ranging without knowledge of the spacecraft motion or the light-travel time between the ground station and the spacecraft [7].

The performance specifications of GRACE, GRAIL, and New Horizons represent an emerging class of spacecraft RF systems where the requirements driven by the science mission demand the selection of a USO for the payload, which then can be leveraged for improved communications and navigation effects. The delivered performance of the GRAIL USOs demonstrate confidence that future mission designs should consider this highly useful combination of reliability, science return, and remote navigation augmentation.

## GRAIL USO PERFORMANCE DATA

JHU/APL produced four USOs for the GRAIL program over the course of 14 months and delivered these units to JPL in March of 2010 for integration into the microwave ranging instrument. The subsequent performance verification of the flight microwave ranging instrument by JPL is discussed in [4]. Testing at JHU/APL consisted of measuring the USO's frequency stability, phase noise, and sensitivity to environmental influences such as temperature, vibration, power supply changes, and exposure to vacuum. Figure 5 is a diagram of the GRAIL USO acceptance test plan showing the sequence of test flow through the required environmental exposures.

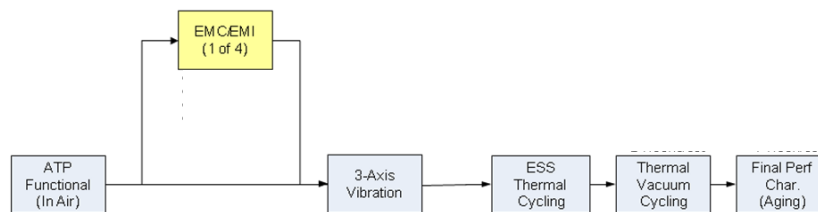

Fig. 5. Acceptance test flow for GRAIL USOs at JHU/APL.

Figures 6 and 7 respectively show the input power consumption and frequency accuracy trending of all four USOs over the acceptance test environmental exposures. In the figures, the test conditions are grouped to the test phases of Fig. 5 as follows;

- Test conditions 1 to 3 Functional test in air at nominal and power supply extremes
- Test conditions 4 to 7 Functional tests over three-axis vibration
- Test conditions 8 to 17 Functional tests under Environmental Stress Screening (ESS)
- Test conditions 18 to 25 Performance tests under thermal-vacuum (TVAC) cycling.

The results show both consistency and conformance of the USOs over the testing conditions of the test plan. This consistency in performance has a high value to the GRAIL program in its selection of flight candidates, of which only two of the units are to be integrated into the satellites. Again, each satellite contains one microwave instrument driven by a single USO. These instruments are slightly offset in frequency to form a pair of phase-locked loops used in the extraction of range between the satellites. The frequency offset is determined by the USO such that the four delivered USOs are actually two sets, one of each of two required frequencies, distinguished by a -09 or -19 in the unit's part number suffix. Since the goal of the program was to select the best performing pair of units to the critical specifications shown in

Table 1, the other functional parameters were desired to be highly similar to facilitate the performance driven selection for flight.

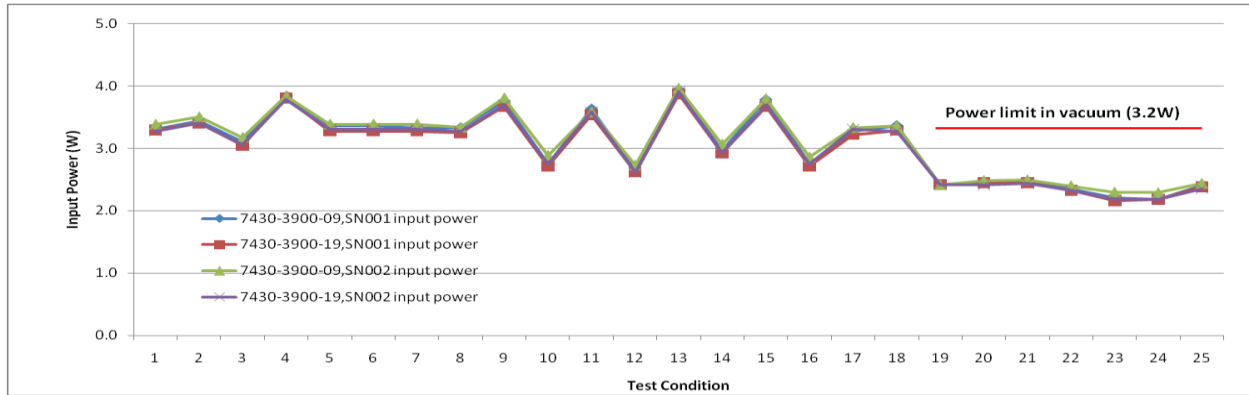

Fig. 6. Input power of the GRAIL USOs over environmental testing; input power under vacuum conditions is a critical specification, shown in Table 1.

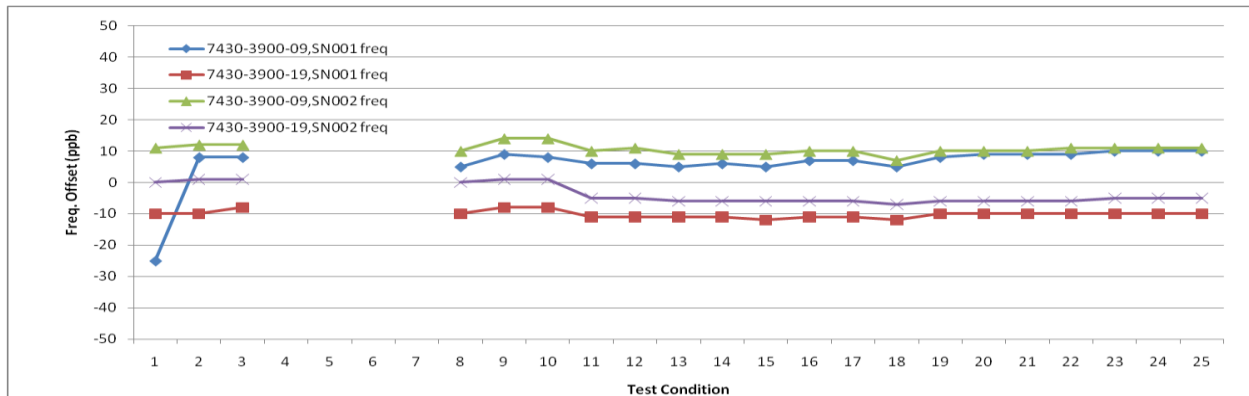

Fig. 7. Frequency accuracy of GRAIL USOs to desired output frequency; frequency accuracy of  $\pm 50$  ppb is a critical specification, shown in Table 1.

All four GRAIL USO units met and surpassed the critical performance specifications shown in Tables 2 and 3. This performance is notable in several aspects. The specifications for GRAIL are already pressed toward the highest level of expected performance for quartz resonators. The combination of both low drift (aging) below  $1 \text{ E-}10$  and low noise (frequency stability below  $2 \text{ E-}13$  in the 10 to 100 s region) represents a highly constrained acceptance yield in resonator manufacturability. The positive correlation of low aging and low noise performance in quartz resonators is not certain, and almost nonexistent in practice. This means that resonators that show excellent noise may not have the desired low drift characteristic; conversely, the best aging resonators may not have acceptable noise. Therefore, to achieve four units that meet or exceed both of these critical performance specifications is a benchmark in JHU/APL USO production.



Table 2. Performance of four USOs to the GRAIL critical specifications; note aging rate per day.

<b>Performance parameter</b>	<b>7430-3900 -09,SN001</b>	<b>7430-3900 -19,SN001</b>	<b>7430-3900 -09,SN002</b>	<b>7430-3900 -19,SN002</b>	<b>Spec. limit</b>
Warm-up time at -20 C	0.8	0.8	0.75	0.7	<b>2 hour</b>
Steady state power at 10C	2.5	2.4	2.5	2.4	<b>3.2 W</b>
Temp Sensitivity	4.1E-13	3.8E-13	2.7E-13	4.5E-13	<b>1E-12/C</b>
Volt Sensitivity	<<1E-12	<< 1E-12	<<1E-12	<< 1E-12	<b>1E-12/V</b>
Aging rate per day	4.7E-11	-1.2E-11	4.2E-11	6.2E-11	<b>7.0E-11</b>
Days to meet aging	6.5	2.5	5.0	4.0	<b>30 days</b>

Table 3. Performance of four USOs to the GRAIL frequency stability specifications; note 10 s performance of units 7430-3900-09, SN 001 and 7430-3900-19, SN 002.

	<b>Adev</b>	<b>Adev</b>	<b>Adev</b>	<b>Adev</b>	<b>Adev</b>
<b>Time interval</b>	<b>1 s</b>	<b>10 s</b>	<b>100 s</b>	<b>1000 s</b>	<b>57600 s</b>
<b>Spec. limit</b>	<b>3.0E-13</b>	<b>3.0E-13</b>	<b>3.0E-13</b>	<b>6.0E-13</b>	<b>5.0E-11</b>
7430-3900-09,SN 001	2.8E-13	9.3E-14	1.1E-13	3.1E-13	1.6E-11
7430-3900-19,SN 001	2.8E-13	1.7E-13	1.2E-13	1.5E-13	2.9E-12
7430-3900-09,SN 002	2.8E-13	1.4E-13	1.1E-13	4.3E-13	1.8E-11
7430-3900-19,SN 002	2.5E-13	8.3E-14	1.6E-13	3.6E-13	2.1E-11

The frequency stability of the four GRAIL USOs shown in Table 3 offers very good performance for the JPL microwave instrument. The 10 s stability of units 7430-3900-09, SN 001 and 7430-3900-19, SN 002 approach 4 E-14, which is considered the best reported performance for quartz resonators of the type used in the JHU/APL USOs (5 MHz, 3<sup>rd</sup> overtone SC-cut) [8]. Using the stability numbers of these two oscillators provides an estimate for the level of uncertainty on the GRAIL DOWR instrument of about 29 microns, which agrees with the verification results found by JPL in [4].

Figures 8 and 9 provide further detail on the performance of one of the best GRAIL units, 7417-3900-19, SN002. As previously discussed, the GRAIL DOWR microwave instrument is not only critically dependent on low noise, but also on timing accuracy to properly compare the phase information measured by each loop. Ideally, the difference between the time tags on each loop's measurement should approach simultaneity. In GRACE, this level of timing accuracy is achieved through near continuous monitoring of GPS. The GRAIL mission design must allow for up to 8 hours of unobserved clock performance, resulting in the need for a highly constrained drift rate. Fig. 8 shows the frequency trend of unit 7417-3900-19, SN002 in vacuum conditions over several days after start-up. Figure 9 shows the trend of change in the frequency drift (aging) on a per day basis over the same period and conditions. Both figures



show the classic diminishing aging rate of USO quartz resonators expected in the vacuum of the space environment. This diminishing aging rate is important for GRAIL, as the USOs will be energized during the nearly 4-month trans-lunar cruise phase [9]. This extended period of operation will allow the USOs to significantly mature to their lowest intrinsic aging rate and give the clock correction capability of the GRAIL TTS a high degree of certainty.

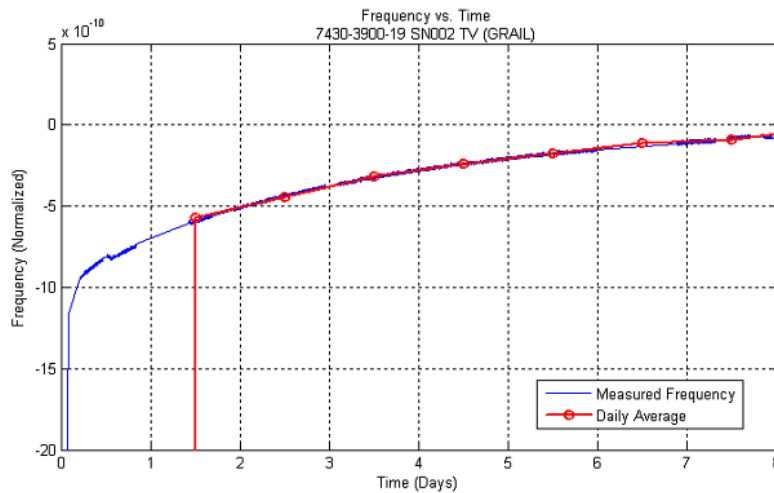

Fig. 8. Frequency trend of unit 7430-3900-19, SN 002 under vacuum conditions.

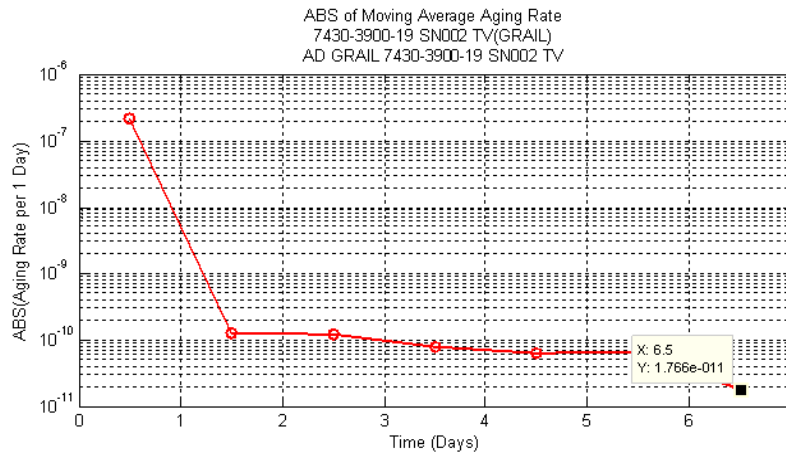

Fig. 9. Frequency drift of unit 7430-3900-19, SN 002 on a per day basis, approaching 1.5 E-11 by day 7 of operation in vacuum.

## CONCLUSION: LOOKING FORWARD TO THE SUCCESS OF GRAIL

JHU/APL has delivered four highly capable USOs to JPL for integration into the DOWR microwave instrument of the GRAIL mission to measure the gravity field of the Moon. The frequency stability performance of the four units surpasses the demanding specifications required by the GRAIL program.

The consistency and conformance of the units facilitate the selection of the best performing pair of units to be installed on to the satellites. Since the quality of the science return from the mission is directly dependent on the USOs frequency stability, the promise of GRAIL to contribute greatly to the understanding of the structure of the Moon – perhaps revealing the extent and composition of its inner core – seems more likely. Success of the GRAIL approach to accomplish precise gravity determination at remote bodies far from Earth extends the possibility of measuring other moons, planets, and asteroids in future science mission concepts. The use of USOs in deep-space science, such as New Horizons and GRAIL, appears to be headed toward an expanded role, taking advantage of not only reliability and low noise, but also aiding navigation and orbit determination.

## ACKNOWLEDGMENT

The authors offer a large feeling of gratitude to the GRAIL program for the opportunity to participate toward its mission goals and objectives. We want to recognize the high degree of collaboration and team work experienced during the design, fabrication, and testing of the USOs with both the GRAIL program and JPL. Specifically, the authors acknowledge Sami Asmar, William Klipstein, Charlie Bell, Kamal Oudrhiri, and Charlie Dunn for their help, support, and interest in assuring the USOs produced by JHU/APL were of the highest quality and best performance. The Moon will be a much more familiar place after June 2012.

## REFERENCES

- [1] M. Zuber, 2008, [moon.mit.edu/overview.html](http://moon.mit.edu/overview.html), also [moon.mit.edu/objectives.html](http://moon.mit.edu/objectives.html), NASA Grant supported Web site (site design, construction, and maintained by R.S. Hildebrand).
- [2] R. Schmidt, 2006, “*GRACE Observations of Changes in Continental Water Storage*,” **Global and Planetary Change**, **50**, 112-126.
- [3] J. B. Thomas, 1999, “*An Analysis of Gravity Field Estimation Based on Intersatellite Dual One-way Biased Ranging*,” 98-15 (Jet Propulsion Laboratory, Pasadena).
- [4] D. G. Enzer, R. T. Wang, and W. M. Klipstein, 2010, “*GRAIL – A Microwave Ranging Instrument to Map Out the Lunar Gravity Field*,” in Proceedings of the 2010 IEEE International Frequency Control Symposium, 2-4 June 2010, Newport Beach, California, USA (IEEE), pp. 572-577.
- [5] W. Bertiger *et al.*, 2002, “*GRACE: Millimeters and Microns in Orbit*,” in Proceedings of the ION GPS 2002 Meeting, 24-27 September 2002, Portland Oregon, USA (Institute of Navigation, Alexandria, Virginia), pp. 2022-2029.
- [6] C. C. DeBoy, C. B. Haskins, T. A. Brown, R. C. Schulze, M. A. Bernacik, J. R. Jensen, W. Millard, D. Duven, and S. Hill, 2004, “*The RF Telecommunications System for the New Horizons Mission to Pluto*,” in Proceedings of the IEEE Aerospace Conference, 6-13 March 2004, Big Sky, Montana, USA (IEEE), pp. 1463-1478.
- [7] J. R. Jensen and G. L. Weaver, 2008, “*The In-flight Frequency Behavior of Two Ultra-stable Oscillators On-board the New Horizons Spacecraft*,” in Proceedings of the 39th Annual Precise Time and Time Interval (PTTI) Systems and Applications Meeting, 27-29 November 2007, Long Beach, California, USA (U.S. Naval Observatory, Washington, D.C.), pp. 79-93.

- [8] A. Kuna, J. Cermak, L. Sojdr, P. Salzenstein, and F. Lefebvre, 2009, “*Lowest Flicker-Frequency Floor Measured on BVA Oscillators,*” in Proceedings of the Joint Conference of the 22<sup>nd</sup> European frequency and Time Forum (EFTF) and the IEEE International Frequency Control Symposium, 20-24 April 2009, Besançon, France (IEEE), pp. 185-187.
- [9] T. L. Hoffman, 2009, “*GRAIL: Gravity Mapping the Moon,*” in Proceedings of the IEEE Aerospace Conference, 7-14 March 2009, Big Sky, Montana, USA (IEEE), pp. 1-8.

