

THE COMMON TIME MODULE, A ROBUST TIME MAINTENANCE SYSTEM

Andrew Dowd and Dr. R. Michael Garvey
Symmetricom, Inc.

Abstract

The Common Time Module (CTM) is being developed by Symmetricom with support from the US Army/CERDEC. The goal is to implement timing services for mobile systems that demand a high degree of reliability and precision. The system is based around a core module that implements a time and frequency server with provisions for legacy time protocols. To address the rigors of a mobile and dynamic environment, the CTM manages multiple connections to the common time reference (UTC-USNO). Either GNSS signals (GPS) or a network connection (IEEE-1588) can synchronize local time services. In addition, the CTM integrates a low-power atomic resonator for extended holdover capabilities. By dynamically managing these technologies, the CTM can supply accurate time and frequency in a wide range of deployment scenarios. Furthermore, improvements in low-power technology such as Chip-Scale-Atomic-Clock (CSAC) will dramatically reduce power requirement, which is a significant advantage to mobile systems. Finally, this paper will examine how standardized IEEE-1588 network techniques will be applied to support redundancy with the CTM.

1 INTRODUCTION: WHAT IS THE CTM?

Common Time Module (CTM) is a development program investigating techniques for implementing accurate timing resources on mobile platforms. It is being developed by Symmetricom and managed by CERDEC Command and Control Directorate (C2D) under contract # WP15P7T-08-C-V205. CTM is a three-phase program and is nearing the end of Phase II. Although the program goals include a system-centric view of mobile platforms, this is not uniquely a paper study. The program is developing a prototype time server module that forms the backbone of the proposed architecture. This module is also referred to as the CTM.



The goal of the program is to develop a core timing capability that can be used on multiple platforms and deployment architectures. Baseline program goals call for a high level of timing performance married to system goals of robustness, reliability, and scalability. To demonstrate this capability, Symmetricom is developing a time server module testbed for Phase II of the contract. Using lessons learned during Phase II, a prototype module will be demonstrated in Phase III.

2 DEPLOYMENT ENVIRONMENTS

CTM is designed to support mobile platforms such as the examples listed in **Error! Reference source not found.** The target space would have a limited number of time clients and it is not expected to support wide-area networking. These systems are centrally defined and controlled. Therefore, we can

assume some level of coordination in the system definition. This has the advantage of avoiding issues associated with open-network elements that can adversely impact the overall system timing performance. However, application of industry standard techniques and COTS methodology is a requirement for interoperability and system maintenance and low life-cycle cost. The program must leveraging industry standard techniques and protocols with mitigation strategies to maintain the desired performance levels in a military environment.

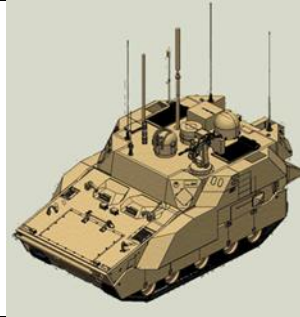
Table 1. CTM Candidate Platforms.

Platforms	Infantry Carrier Vehicle	Command and Control Vehicle	Warfighter (eventually)
			
Relative System Size	Medium-small	Medium	Small
Unique Requirements	Legacy Support, Holdover time	Legacy Support, Redundancy	Holdover Capability, Lowest Power
Typical Configuration	Single CTM, small network	Dual CTM, redundancy	Single CTM, no network

3 PROGRAM GOALS

With the target environment defined, the next step is to consider the program goals in more detail and define the CTM approach to meeting these requirements.

3.1 CENTRAL TIME SERVICE

Robust and accurate time is frequently a requirement for instrument packages in modern mobile platforms. In many programs, time maintenance requirements are dispersed among different instrument packages and vendors, which can create unnecessary duplication of functionality. This approach can drive up power (and cooling) requirements on the final system. Frequently, the resulting duplication of timing equipment provides no effective redundancy and overall timing reliability is suboptimum. The CTM will address the somewhat conflicting goals of reduced system power, while providing capabilities for redundancy and fault tolerance.

3.2 ROBUST AND RELIABLE TIME

As discussed above, a central time server provides key advantages. However, an equally important goal of this program is to identify ways to improve system reliability and robustness. Naturally, a centralized resource is, in effect, a single-point of failure and tends to diminish this attribute. To achieve both goals,

CTM can serve as a Master Clock in a distributed, network-centric implementation. This allows the CTM to leverage a large number of industry standard techniques for fault tolerance and redundancy. Such properties are easy to implement in Ethernet-based networks, which are designed for fault tolerance. Overall, it has been our conclusion that network-based time distribution is the best approach to achieving this goal.

3.3 SCALABILITY

Figure 1 shows a simple non-networked application of the CTM. In this implementation topology, the CTM supplements GPS time with a disciplined rubidium (Rb) oscillator holdover feature. Time is available to users via a legacy port, such as AN/PSN-11 TOD or PPS. This CTM topology can support small platforms, including a near-term goal of extending this capability to instrument packages carried by individuals (warfighter).

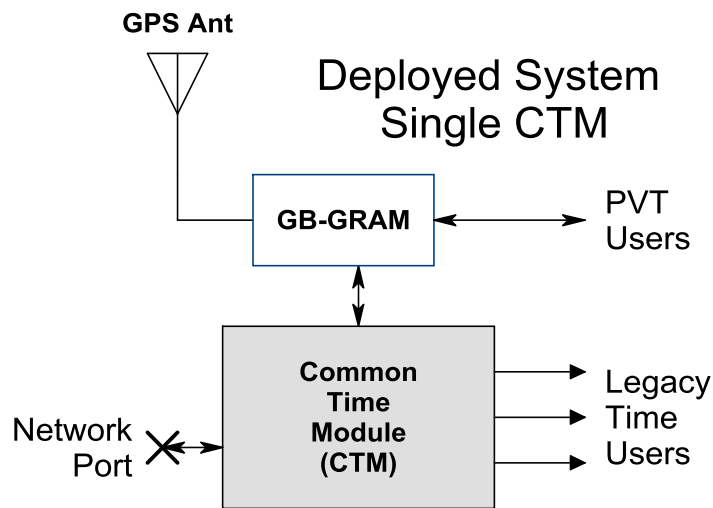

Figure 1. Simple CTM system deployment.

Beyond the minimal system described above, the CTM implements networking to support more complex platforms. This paper will explore how networking is the essential ingredient to enabling scalability for the CTM.

4 CTM PROTOTYPE

Before discussing in detail how the CTM prototype will achieve program goals, it is useful to introduce the features of the proposed module. This section will highlight important elements of the design, including a brief description of subsystems in the proposed module and key features. A block diagram of the CTM is shown in Figure 2. This section provides a brief overview of subsystems in the proposed module and key features.

4.1 TIME ENGINE – GPS-DISCIPLINED RB OSCILLATOR

At its core, the CTM is a time server that requires a traceable connection to the desired time reference (in this case, UTC-USNO). For mobile operations, a GPS receiver is the most practical link to UTC. This program will rely on an off-board IS-GPS-153 compliant GPS receiver. The Time Engine module accepts GPS/UTC time from the Ground-Based GPS Receiver Application Module (GB-GRAM) and disciplines its Rb-oscillator time and frequency to provide holdover capability. This extends precision timing to areas of operation where GPS is denied or degraded. Looking at this feature another way, a disciplined Rb oscillator provides the first level of reliability to time maintenance capability.

4.2 HOLDOVER OSCILLATOR

To implement the holdover Rb oscillator, CTM includes an integrated Chip Scale Atomic Clock (CSAC) 0. CSAC provides Rb atomic clock performance, requiring only 100 mW of power. This helps achieve the overall objective of low-power operation with atomic clock holdover performance. Figure 3 shows the CSAC installed on the CTM Phase II Time Engine breadboard.

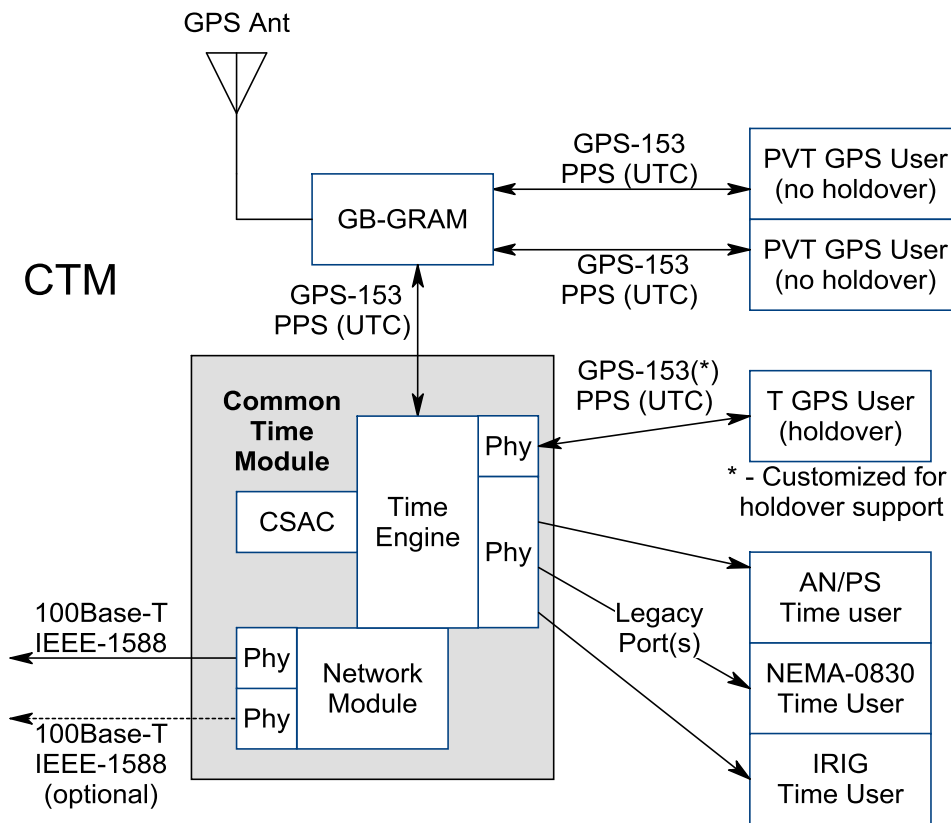

Figure 2. CTM block diagram.



Figure 3. CTM Phase II Time Engine breadboard.

4.3 NETWORK MODULE

Networking capability is a fundamental feature of the CTM. The CTM can have 0, 1, or 2 physical Ethernet ports installed. Each CTM has the capability to operate as an IEEE-1588 Grand Master, Alternate Master, or Ordinary Clock **0**. Networking on the CTM can be used to both serve and receive time, as the situation demands. The second network port allows the CTM to operate despite the failure of any one network link. This works best when the ports are connected through different Ethernet switches.

4.4 LEGACY TIME DISTRIBUTION

The CTM is a forward-looking design, but must accommodate legacy equipment. To that end, each CTM has dedicated legacy ports that supply time via AN/PSN-11 TOD port (variant of HaveQuick), NMEA-0183, and IRIG. Each CTM in the system cluster will be able to service local time users with these ports.

4.5 CTM KEY FEATURES – OVERVIEW

- GPS Receiver (GB-GRAM) is the primary time reference
- Disciplined CSAC to support holdover time for GPS-denied environments
- Network Time via PTP (IEEE-1588 v2)
- Legacy time distribution
- Low power design

5 SYSTEM CONSIDERATIONS

5.1 TIME TRANSFER ACCURACY

The key function of the CTM is to distribute time to client instruments. To deliver accurate time, it is important to consider the inherent accuracy of the technique used to communicate time to the client. **Error! Reference source not found.** lists the time transfer mechanisms available with the CTM. Precision Time Protocol (PTP), in constrained network configurations, can achieve very accurate time transfers (sub-ns performance have been reported [2-4]) in a very economical transport medium (Ethernet cable). In practice, to achieve these high levels of performance, system integrators must control network elements and cabling. For the envisioned applications (**Error! Reference source not found.**), this controlled type of system design is feasible. The following lists some of the network implementation issues that can impact PTP performance.

1. Time-stamping Implementation – CTM will implement precise hardware time-stamping of PTP packets, but Slaves can implement sub-optimum designs and still claim compliance to the standard. Fortunately, this does not negatively impact other users.
2. COTS Network Switches and Routers – By inserting a non-1588 compliant switch, PTP performance can be severely degraded, due to unpredictable packet queuing delays.
3. Traffic Levels – Communications activity on a shared network can impact PTP performance. While a fully realized IEEE-1588 network is fairly resilient to degradation by superfluous network traffic **0**, there is some modest falloff that must be quantified. For critical applications where PTP must be optimized, separate network elements are an acceptable solution (keep PTP off the high traffic network).
4. Cabling and Interconnect – To achieve the highest level of performance, cabling issues must be considered **0**.

One of the activities planned for CTM Phase III is to quantify the time transfer performance of PTP in small networks, such as the ones sketched in Figure 4, 5, & 6.

5.2 POWER CONSUMPTION

Reducing system power consumption is an explicit goal of the CTM program. Replacing a heterogeneous mix of custom timing systems by a single CTM-based server is one method of achieving this goal. However, to maintain this advantage, the CTM must be inherently low power. The CTM uses techniques and parts selection to keep power consumption low. The breadboard CTM Time Engine requires less than 3 watts, including the CSAC holdover oscillator. Further improvements are possible as the prototype design is clarified.

Table 2. Time transfer techniques.

	Network Standards		Point-to-Point Legacy Standards		
	IEEE-1588 (PTP)	NTP	NMEA- 0183	IRIG	PPS
peak time transfer error (typ)	1-100 ns	100 ms	~1 ms	1-10 us	< 1ns
Physical	IEE-1588 compliant Ethernet	Standard Ethernet	RS-232, RS-422	RF Coax	Digital Logic
Style	Master/ slave(s)	Client(s) / Server	Master/ slave	Master/ slave	Master/ slave
Automatic latency correction	Yes	Yes	No	No	No
Notes					No Time of Day

5.2.1 BATTERY-BACKED HOLDOVER OSCILLATOR

The CSAC oscillator requires only 100 mW of power. It includes an internal 1 pps subsystem that can be used to store and recover time. Therefore, the CSAC can support a “warm-restart” mode of the CTM that requires only 100 mW during the low-power holdover period. This mode is within range of battery powered operation.

For example, an ordinary commercial 12 V lead-acid car battery has about 500 watt-hours of capacity. Thus, a CSAC could remain powered for ~200 days from that battery. As an added advantage, a CSAC emerging from a warm-start condition is not subject to the normal cold-start drift effects that degrade the performance of all high-precision quartz oscillators. Specified aging performance is available immediately.

5.3 RELIABILITY, REDUNDANCY, FAULT TOLERANCE, AND NETWORKING

Within industry publications on Ethernet networking, the subject of redundancy, fault tolerance, and reality represents a broad and active area. The IEEE-1588 protocols are particularly relevant to this discussion. While even a brief overview of this topic is well beyond the scope of a single paper, it is worth examining some relevant techniques that are particularly well suited to the target applications planned for the CTM. In addition, because many of the 1588 protocols have broad commercial applicability, the robust performance that is derived from an enormous installed base is evident.

5.3.1 Best Master Clock Algorithm

The Best Master Clock (BMC) is an IEEE-1588 standard mechanism for dynamic selection of a Master Clocks used by network Slave Clocks. It provides fault tolerance because a CTM that is a Master or a CTM Ordinary Clock will start sending announce messages and sync messages if they don’t hear from a better Master. So if the original Best Master stops sending messages for any reason, another Clock will

automatically take over. The BMC provides a deterministic algorithm for dynamically defining which CTM will be source time to the network. Configuration parameters allow Master succession to be defined by a system integrator, or happen automatically as a function of each device's broadcast "clock quality."

5.3.2 Alternate Master Clock

If an IEEE-1588 Grandmaster fails or degrades substantially, the BMC will automatically trigger the transition of Slave Clocks to the next best Clock (in this case, presumed to be another CTM). While this transition is automatic, there is a transition period when the Slaves resynchronize themselves to a new CTM Grandmaster. By implementing an "Alternate" Master, another CTM can operate as a "hot-spare," which will speed transition and help maintain accurate time distribution. The Alternate Master function can also be used by Slaves to compare one Master to another and implement a voting or ensemble synchronization schemes. This allows Slaves to stay on time even if the Best Master is drifting off time, but reporting itself as healthy.

5.3.3 PRP

A number of techniques exist to address cable failures in fault-tolerant network design. Parallel Redundancy Protocol (PRP) makes use of two independent Ethernet networks. Frames are replicated by the sending node and transmitted over both networks. This scheme works without explicit reconfiguration and switchover and, therefore, does not show a period of unavailability. It can provide a high level of fault tolerance to cabling failures and is the driver for the CTM optional support of two Ethernet ports. Adapting IEEE 1588 to PRP and other redundant Ethernet protocols is currently an area of active research within the industrial automation and power utility industries.

5.3.4 STP and RSTP

The Spanning Tree Protocol (STP) and the Rapid Spanning Tree Protocol (RSTP) are two techniques that provide fault tolerance without a complete set of redundant Ethernet connections and cabling. The idea is to use alternate connection paths either by a ring or tree topology.

5.4 REPRESENTATIVE CTM-BASED SYSTEMS

The following section describes selective system configurations of the CTM. This is not a comprehensive list, but shows ways the CTMs can be applied to achieve different requirements.

5.4.1 Fully Redundant CTMs

Figure 4 shows a case where two CTMs on a platform are directly connected via network crossover cable. Each can operate independently as a PTP Grandmaster clock. The other CTM will automatically configure itself as an Ordinary Clock (or an Alternate Master). This simple arrangement provides a substantial amount of fault tolerance. The loss of either GPS antenna and/or GPS receiver would trigger the BMC algorithm and switch the network's Grandmaster. Using PTP, the legacy ports will continue to provide accurate time on BOTH units, because a single GPS failure would not prevent time transfers from the fully-operational CTM.

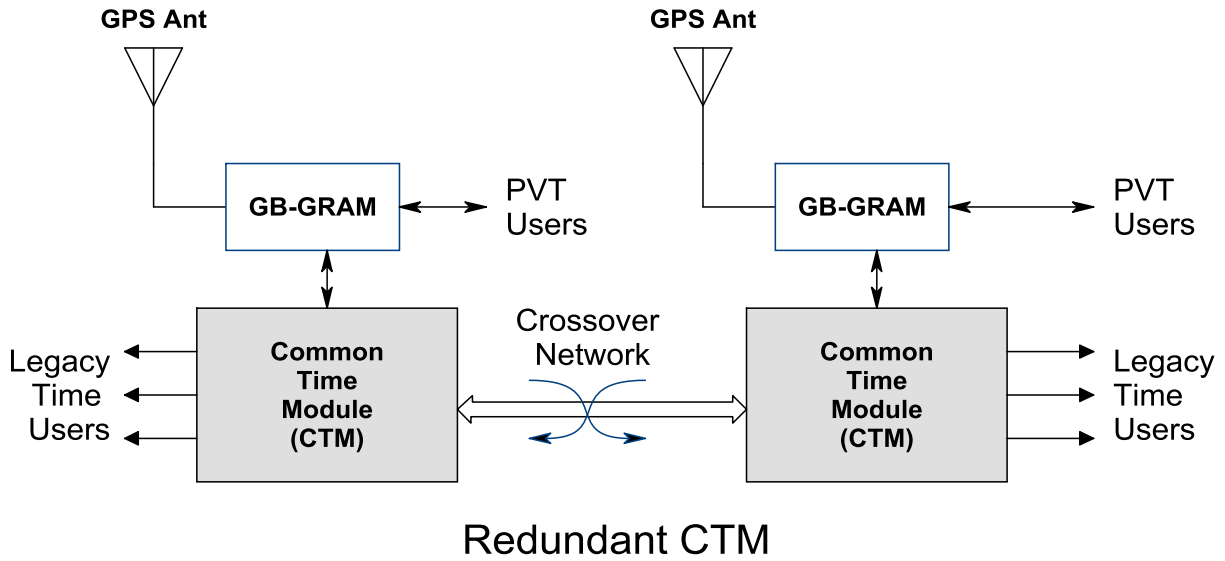

Figure 4. Fully redundant CTMs.

5.4.2 Remote CTM (Time Repeater)

Figure 5 shows another system topology with two CTMs. As before, both CTMs can supply time to legacy users from their respective ports. But in this case, one CTM will NOT have access to a GB-GRAM and, therefore, cannot operate as a redundant Grandmaster. However, it can receive time via its network connection and, therefore, can supply precision time to its legacy ports. Thus, the CTM becomes a legacy port “repeater” which extends time services using Ethernet. Furthermore, the remote CTM still has holdover capabilities and can continue supplying precision (holdover) time for some period after a cable failure.

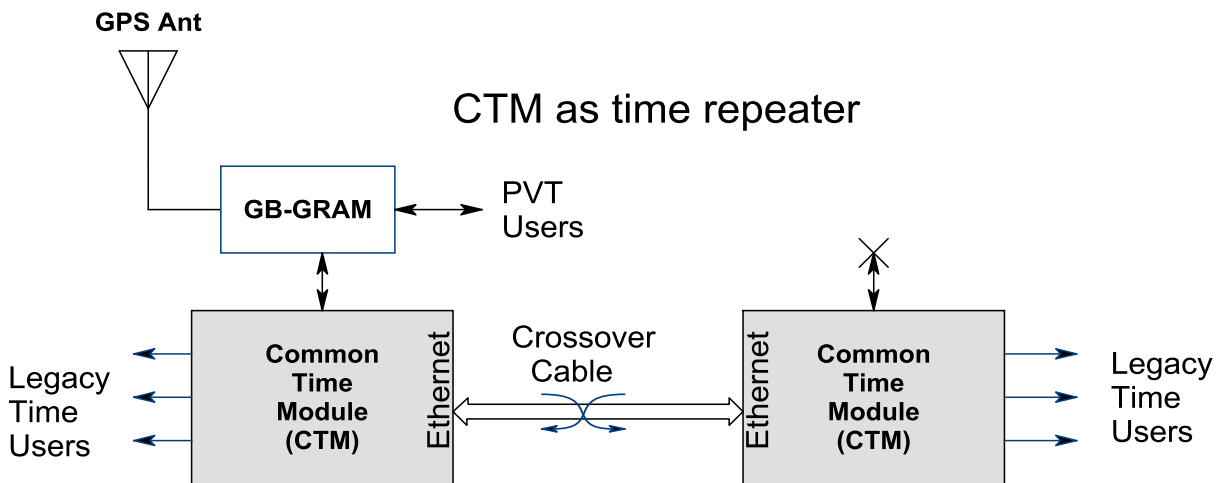

Figure 5. Remote CTM.

5.4.3 Fully Redundant CTMs with Network Time Distribution

The next system shows a medium-sized deployment with two CTM masters and two network time users. This provides redundancy using two CTMs and shows instruments getting precision time from the network.

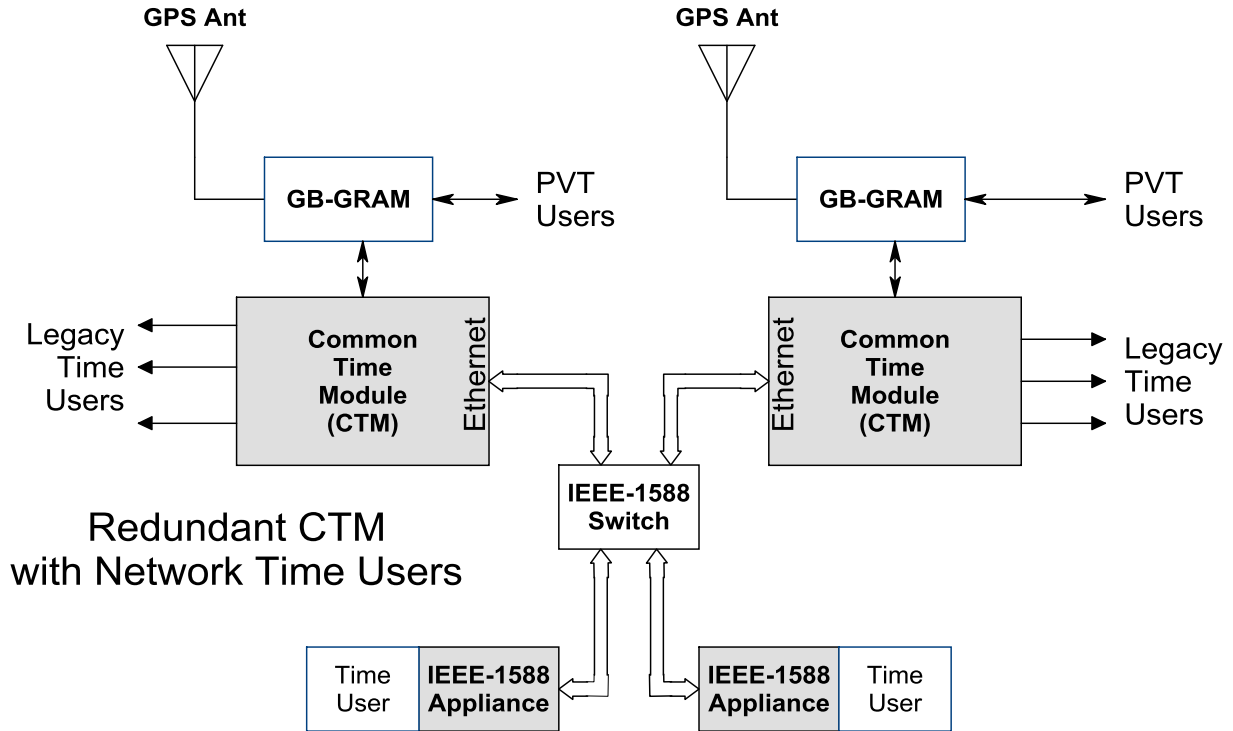

Figure 6. Full network time system.

5.5 SYSTEM FIELD MAINTENANCE

The IEEE-1588-based implementation provides another advantage to system developers. In most cases, it configures and optimizes itself. The Best-Master algorithm will automatically accommodate multiple CTMs. Using the power of networking and existing IEEE-1588 standard features, the system will control and optimize itself without user intervention.

5.6 IEEE-1588 APPLIANCE

The first generation of systems that use the CTM will undoubtedly rely on legacy ports for time distribution. Also, as shown in Figure 4, the Ethernet port can be used for pure CTM-to-CTM communications. However, the advantages of using network-based time distribution will eventually lead instrument developers towards IEEE-1588 for time distribution. To jumpstart this effort and ensure consistent performance, the development of a small embeddable module that acts as a simple Slave Clock has great potential for CTM adoption. This module (an “IEEE-1588 Appliance”) would implement the necessary packet hardware time-stamping and provide the instrument designer Time-of-Day (TOD) and Pulse per Second (PPS). Unlike the full CTM, an IEEE-1588 appliance would always be a Slave Clock

and holdover is optional (this capability is supplied by the CTM-based Grandmaster). In low-power instrument packages, the addition of Power over Ethernet (PoE) could simplify system integration effort using industry standard techniques.

6 CONCLUSIONS

The CTM was conceived as a core module with the capability to support a wide range of mobile platforms with a precision time resource. The core timing engine uses a GPS-disciplined CSAC for ultra-low power consumption and Rb oscillator performance. By combining a solid time maintenance engine with a fully compliant 1588 Master Clock module, it is possible to support a wide range of fault-tolerant and redundant timing system implementations. Furthermore, a network-centric approach using IEEE-1588 provides self configuring (and reconfigurable) operations that minimize system maintenance issues.

7 ACKNOWLEDGMENTS

The authors deeply appreciate the following contributors for valuable technical, theoretical, and moral support: Dr. Doug Arnold and Dr. Samuel Stein of Symmetricom and Dr. Raymond Filler of US Army CERDEC C2D.

8 REFERENCES

- [1] R. Lutwak *et al.*, 2008, “*The Chip-Scale Atomic Clock – Prototype Evaluation*,” in Proceedings of the 39th Annual Precise Time and Time Interval (PTTI) Systems and Applications Meeting, 27-29 November 2007, Long Beach, California, USA (U.S. Naval Observatory, Washington, D.C.), pp. 269-290.
- [2] D. Arnold, 2008, “IEEE 1588 Tutorial,” in Proceedings of the 2008 IEEE International Frequency Control Symposium (FCS), 18-21 May 2008, Honolulu, Hawaii, USA (IEEE CFP08FRE-CDR), pp. xiii-xviii.
- [3] P. Moreira, J. Sarrano, T. Wlostowski, P. Loschmidt, and G. Gederer, 2009, “*White Rabbit: Sub-nanosecond Timing Distribution Over Ethernet*,” in Proceedings of the International IEEE Symposium on Precise Clock Synchronization for Measurement, Control, and Communication (ISPCS), 12-16 October 2009, Brescia, Italy, pp. 58-61.
- [4] P. Loschmidt, R. Exel, A. Nagy, and G. Gaderer, “*Limits of Synchronization Accuracy Using Hardware Support in IEEE 1588*,” in Proceedings of the International IEEE Symposium on Precise Clock Synchronization for Measurement, Control, and Communication (ISPCS), 22-26 September 2008, Ann Arbor, Michigan, USA, pp. 12-15.
- [5] M. Christer, S. Passe, and S. Stein, 2007, “*Design of an IEEE-1588 Interface for Sub-Nanosecond Performance*,” presented at the 38th Annual Precise Time and Time interval (PTTI) Systems and Applications, December 2006, Reston, Virginia, USA, but not published in the Proceedings.
- [6] S. Meier and H. Weibel, 2007, “*IEEE 1588 applied in the environment of high availability LANs*,” in Proceedings of the IEEE Symposium on Precise Clock Synchronization for Measurement, Control, and Communication (ISPCS), 1-3 October 2007, Vienna, Austria, pp. 100-104.

- [7] H. Weibel, “*Tutorial on Parallel Redundancy Protocol (PRP)*,” www.engineering.zhaw.ch.
- [8] J. Tournier, K. Weber, and C. Hoga, 2009, “*Precise Time Synchronization on a High Availability Redundant Ring Protocol*,” in Proceedings of the International IEEE Symposium on Precise Clock Synchronization for Measurement, Control, and Communication (ISPCS), 12-16 October 2009, Brescia, Italy.
- [9] IEEE Std. 1588-2008, “*IEEE Standard for a Precision Clock Synchronization Protocol for Networking Measurement and Control Systems*,” March 2008 (IEEE).