

# TIME AND FREQUENCY TRANSFER USING ASYNCHRONOUS FIBER-OPTICAL NETWORKS: PROGRESS REPORT

**K. Jaldehag, S.-C. Ebenhag, P. O. Hedekvist, C. Rieck**  
SP Technical Research Institute of Sweden  
P.O. Box 857, S-501 15 Borås, Sweden  
E-Mail: *kenneth.jaldehag@sp.se*

**P. Löthberg**  
STUPI, LLC, Los Altos, CA, USA

## Abstract

*SP Technical Research Institute of Sweden has since 2004 been running a project with the aim of performing time and frequency transfer using commercial asynchronous fiber-optical networks. The project is motivated by the need for an alternative and complementary time transfer method on a national basis with the goal of reaching accuracy and stability comparable to satellite-based methods. Previous results using an OC-192/STM-64 10-Gb/s packet over SONET/SDH network show that time transfer accuracy of the order of a few nanoseconds is possible on baselines exceeding 500 km [1]. The method is based on passive listening on existing data traffic and the detection of certain bit sequences in the SDH frame headers continuously transmitted by the network routers. By using two-way time transfer, it is possible to estimate and compensate for symmetric delays in the optical fibers. The method relies on the fact that time-dependent residual delays are small or can be compensated for and constant residual delays can be calibrated.*

*This paper briefly revises the method and presents new results in comparison with the GPS carrier-phase technique, with focus on residual effects due to temperature variations, which have been shown to have a significant impact on the stability and accuracy. It also discusses hardware miniaturizations, as well as new ideas for active time transfer using bit-sequence generators/transmitters in dedicated wavelength slots of the optical network. Finally, the use of a subset of the IEEE Standard 1588-2008 (Precise Time Protocol, PTP) for data transport is briefly discussed.*

## INTRODUCTION

A novel method for time and frequency transfer by monitoring the data bit stream transmitted in an optical fiber has been developed and studied since 2004 by the SP Technical Research Institute of Sweden (see, for instance, [1-4]). The method is applicable to any synchronous transmission network, but has so far only been studied in a network based on SDH (Synchronous Digital Hierarchy) transmission using packets over SONET/SDH STM-64, 10 Gbit/s between core IP routers. Unlike previously described methods [5-6], the present method is based on passive monitoring on existing networks and requires no dedicated bandwidth.

The motivation for the present work is to find, using existing infrastructure, an alternative and complementary method to already established satellite-based methods such as GNSS (Global Navigation Satellite Systems), including among others GPS (see, for instance, [7]), and TWSTFT

(Two-Way Satellite Time and Frequency Transfer; see, for instance, [8]). The goal is to reach an accuracy and stability comparable to existing methods.

This paper briefly revises the method and reports on recent progress, both concerning new time transfer results and the development of new hardware. Although departing from the philosophy of passive monitoring, it also discusses the possible use of bit-sequence generators in dedicated wavelength slots that would be motivated at sites not equipped with core IP routers and SDH transmission possibilities. Finally, it also briefly discusses the use of a subset of the IEEE Standard 1588-2008 (Precise Time Protocol, PTP) as a high-level protocol for transport of measurement data.

## DESCRIPTION OF METHOD

SDH defines the transmission of data in nominally 125- $\mu$ s-long frames, where each frame starts with the identical sequence of A1 and A2 bytes that defines the beginning of a new frame (A1=11110110, A2=00101000). At STM-64, this frame-start sequence is 192 A1 bytes followed by 192 A2 bytes. Briefly, in a network using the packet over SONET/SDH (POS) technique, data packets are embedded in SDH (or SONET) frames and transmitted between network core routers located at different nodes in the network. The fundamental concept of the described time transfer method is to measure the epoch when these frame-start sequences are transmitted from a router at one node in combination with measuring the epoch when the same sequences arrive at the receiving router at a second node, with both epochs measured relative to local clocks at each node. This measurement is affected by the path length of the optical fiber and variations in the corresponding time delay, and to succeed in a time transfer, i.e. the remote comparison of the two local clocks, measurements must be performed both for the bit stream leaving the node, as well as the bit stream arriving at the node, i.e. in a two-way sense. Figure 1 shows schematically two-way time transfer between two nodes in a network. Four equations of time interval measurements need to be combined.

The actual transmission rate from each router is dependent on a local oscillator (OCXO) implemented in each router. In the method (see Figure 2), the optical signal received from each router is transformed into an electrical signal using a photo-receiver. The electrical signal goes to the input of a Header Recognizer (HR), which analyzes the bit stream and emits an electrical pulse at every detection of a frame-start, i.e. nominally every 125  $\mu$ s, but in practice dependent on the actual frequency of the OCXO. Each time measurement, according to the above, is, thus, relative to these oscillators.

The method relies on the assumption that the differential path delay and local equipment delays are stable over time and that constant differential path delays can be calibrated. Due to the fact that the transmission delay in the path generally is longer than 125  $\mu$ s (for instance  $\Delta T_A$  in Figure 1), it is implicit that each node does not measure relative to the same pulse within the same time frame (usually 1 second). This implies that it would be necessary to keep track of each pulse, which is difficult in the present implementation. Instead, the method relies on the fact that the short-term stability or the jitter of the local oscillators (OCXO) is small enough to be insignificant. In fact, the jitter of the present oscillator is of the order of 30 ps, which is a factor of 2 less than the precision of the time-interval counters presently used.

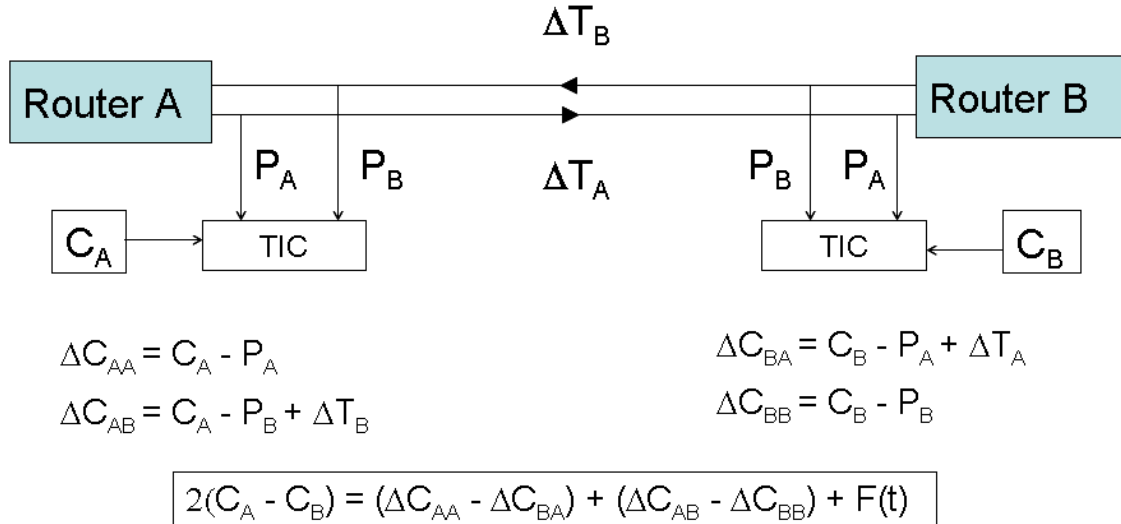

F(t) is differential path delay + local equipment delays

Figure 1. Two-way time transfer between node A and node B containing router A and router B, respectively. The electrical pulse  $P_A$  is generated by a HR [2] at node A. This pulse is measured relative to clock  $C_A$  at node A using a time-interval counter (TIC). The same pulse, when arriving at node B, is measured relative to clock  $C_B$ . Similarly, the pulse  $P_B$  is measured at node B and node A, resulting in a total of four equations that are combined into an expression relating the two clocks A and B. Function  $F(t)$  is the differential path delay ( $\Delta T_A - \Delta T_B$ ) plus local equipment delays.

To implement the system in a network, each fiber is equipped with two passive fiber-optic power-splitters close to the measurement systems. At the transmitter, where the power level is high, 1% of the light is split-off to the photo-receiver, and at the receiving end, where the power level is low, 10% is split-off. The 11% added loss to the fiber transmission will decrease the power margin of the system, but it is anticipated that all systems are implemented with a far higher margin. All experiments performed so far have also validated this assumption.

## RECENT RESULTS

### TW-FIBER TIME LINK BETWEEN SP AND STUPI: HARDWARE

One TW-fiber time link using the method described above has been maintained continuously for more than 1 year between two laboratories in Sweden [1], namely the national laboratory for time and frequency in Sweden located at SP, Borås, Sweden, and the clock laboratory at STUPI in Stockholm, Sweden. The network distance between the laboratories is 560 km. Both laboratories are equipped with several atomic clocks and maintain time scales referenced from H-masers steered to UTC using auxiliary equipment. The time scales are also continuously compared to each other using GPS carrier-phase equipment. The TW-fiber link is implemented in the Swedish University Network called OptoSUNET [9], which is based on Dense Wavelength Division Multiplexing (DWDM) with 50-GHz spacing and constructed in a star topology with a central hub, such that each node, containing IP routers, across different baselines communicates with the central hub over a dedicated wavelength.

The setup of the link is shown in detail in Figure 2. Each time scale (represented by Clock A + AOG and Clock B + AOG in the figure) is connected to two distribution circuits at 5 MHz and 1-pps. Five

MHz is used as the time base for the time-interval counters (TIC) and 1-pps is used as the reference pulse from the time scales that starts the time interval measurements.

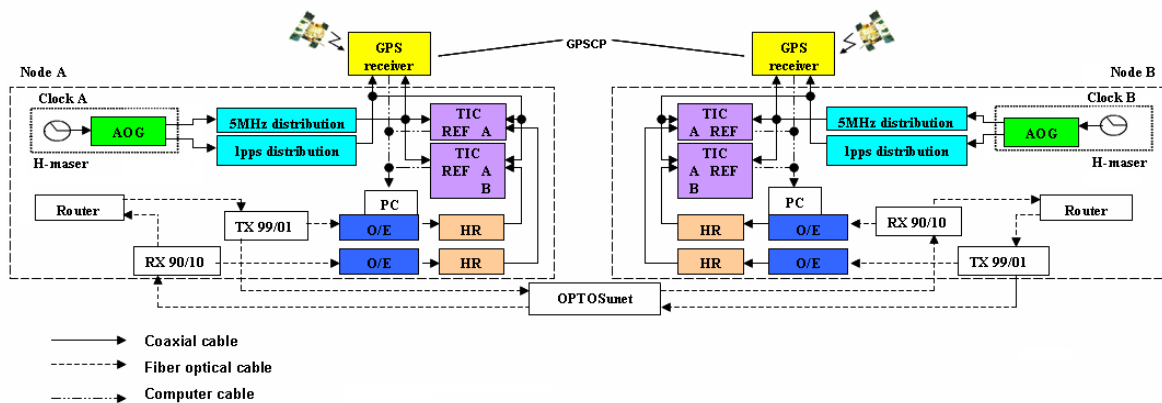

Figure 2. TW-fiber link between two laboratories in Sweden at SP and STUPI and the equipment as described in the text needed for a two-way time transfer. The optical link is compared to a link based on GPS carrier phase.

The photo-receiver (O/E) is a 10-GHz avalanche photodiode (APD) with an integrated trans-impedance amplifier (TIA). Its sensitivity is up to 10 times better than the sensitivity of the receivers in the router. Since the system can operate at a very low power margin, the 10% available power is sufficient. The HR is the device that continuously analyzes the bit stream transmitted over the fiber. At 10 Gbit/s, it searches for the sequence of bits that define the start of a new frame, as described above. Every time this sequence is detected, the HR emits a 25-ns pulse with a sharp slope (25 ps rise-time), which stops the time interval measurements. The HR is based on a Field Programmable Gate Array (FPGA) platform, in combination with 10-Gbit/s input and output circuits. Commercial time-interval counters with a resolution of 100 ps are used.

### TW-FIBER TIME LINK BETWEEN SP AND STUPI: TIME SCALE AND LINK COMPARISON

Figure 3 shows the time scale difference [UTC(SP) – STUPI\_UTC] for almost 5 months in 2009, calculated using the TW-fiber link shown in Figure 2 and the GPS carrier-phase link as calculated by the NRCan software (see, for instance, [10]; abbreviated GPS-link in the following). UTC (SP) is the national time scale of Sweden, the official UTC realization in Sweden and relayed monthly to UTC by the BIPM (International Bureau of Weights and Measures). STUPI\_UTC is steered to UTC, but is not an official UTC realization. Observations are available every 5 minutes for the GPS-link and every 60 seconds for the TW-fiber link. The TW-fiber link data are the single raw measurement taken every minute and is not in any sense smoothed or averaged. Some shorter gaps in the TW-fiber link, due to service and restart of the measurement systems, are also apparent in the figure. The GPS-link data are calculated in monthly batches so that day-boundary jumps only occur once per month. The two time series are aligned in the figure by adjusting the TW-fiber link to the results from the calibrated GPS link.

From the figure, it is clear that the two solutions are in good agreement in a long-term sense. It is also evident that the solution of the TW-fiber link is noisier in the short term and that the two time scales are steered substantially relative to each other, both of which can be seen also in Figure 4 that shows the modified Allan deviation of the two solutions.

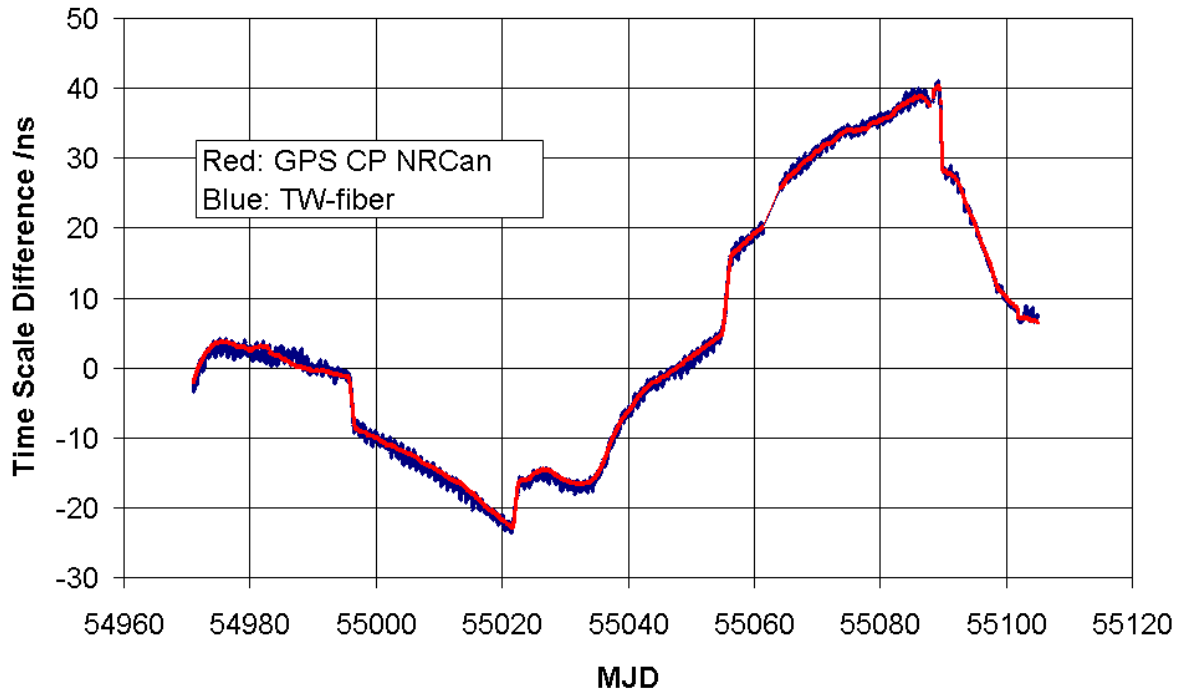

Figure 3. Time scale difference between UTC (SP) and STUPL\_UTC for almost 5 months in 2009, calculated by means of the TW-fiber link and the GPS link, as described in the text. MJD is the Modified Julian Date.

The times series in Figure 3 is, according to Figure 4, affected by white phase noise up to about 30 minutes for the GPS link and up to about 1 hour for the TW-fiber link. The TW-fiber link also shows a daily variation and the long-term stability of both time series are affected by the steering of the two time scales.

In order to see the potential of the TW-fiber method, it is necessary to find a time series in which the steering of the two time scales is minimal. Figure 5 shows such a period of about 20 days earlier in 2009 in which the time series were affected in the long term more or less only by the masers' frequency drift. The TW-fiber link is calculated in the same way as for Figure 3. The carrier phase GPS-link is also calculated in the same way except that the solutions are now in daily batches, as seen in the figure as day-boundary jumps, and data are available every 60 seconds. Included in Figure 5 is also for comparison a solution of the standard GPS P3 link [11] between the two time scales.

Figure 6 shows the stability plot of the times series in Figure 5. Compared to Figure 4, the stability is similar up to an averaging time of about 1000 seconds. At longer averaging times, the stability data are not affected by a steering of the time scales and reaches a level of about  $2 \times 10^{-15}$  at 24 hours.

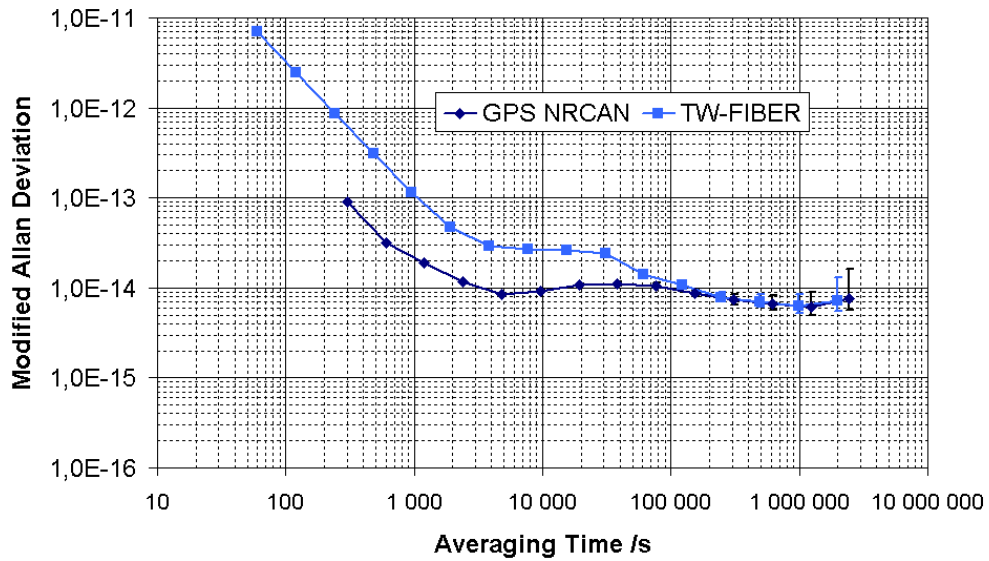

Figure 4. Modified Allan deviation of the two time series shown in Figure 3.

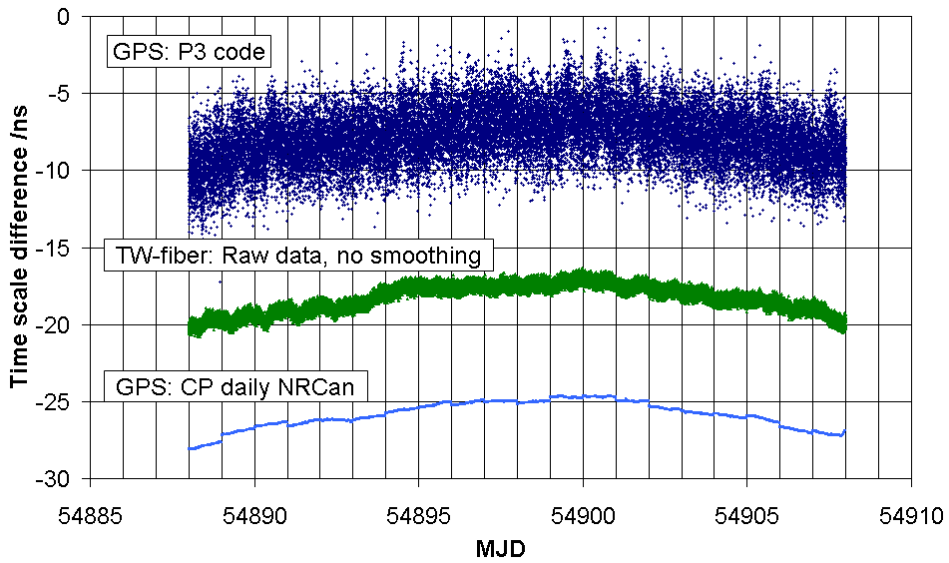

Figure 5. Time scale difference between UTC (SP) and STUPL\_UTC for 20 days in March 2009, calculated by means of the TW-fiber link and the GPS carrier-phase and P3 links, as described in the text. The three time series are vertically offset for clarity.

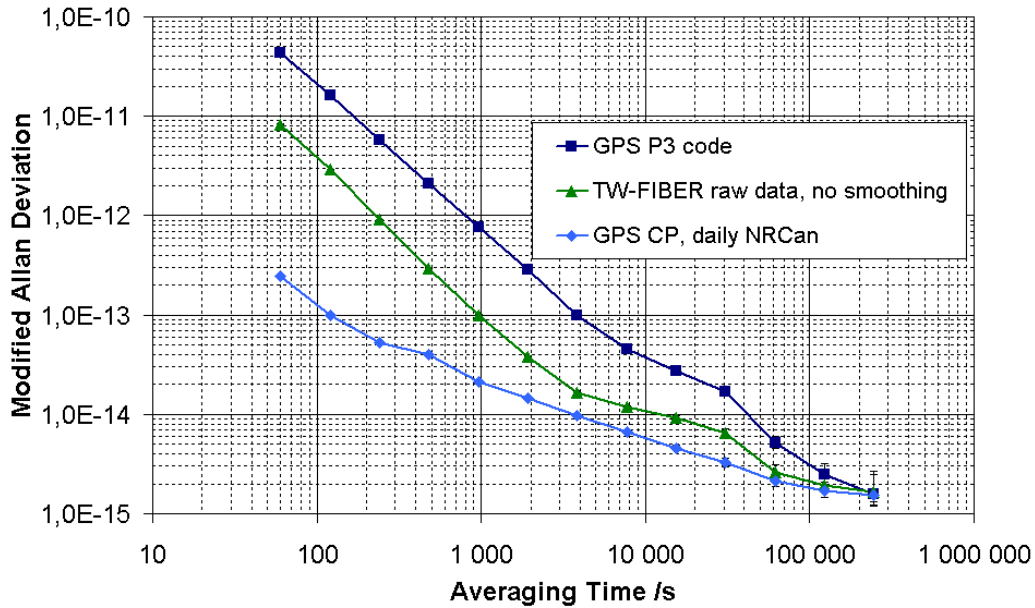

Figure 6. Modified Allan deviation of the three time series shown in Figure 5.

There is still evidence for daily signatures in the TW-fiber link. This is depicted in the following figures showing the difference between the methods. Figure 7 shows the difference between the two time series in Figure 3, i.e. the difference between the TW-fiber link and the carrier-phase GPS link. The RMS-difference over the almost 5 months of data is about 625 ps, including some clear systematic differences of several nanoseconds. Previous results show that the systematic differences are correlated with temperature variations and attempts have been done to correct the data [4].

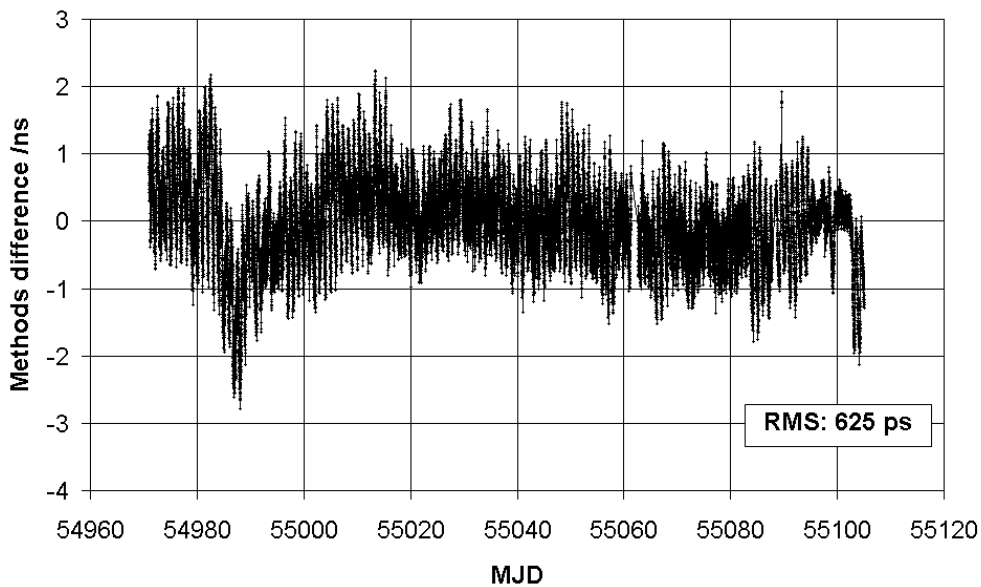

Figure 7. Methods difference of the two time series shown in Figure 3.

Figure 8 shows a subset of the data in Figure 7 together with temperature data taken from outside sensors at SP (Borås), STUPI (Stockholm), and in Örebro, a city approximately halfway between SP and STUPI. Even though the correlation is evident, indeed, the TW-fiber link from SP to STUPI should be affected by temperature variations inside and outside both laboratories, as well as all along

the link. For this particular time period, the temperature variations are similar at the three cities, but at other occasions the mixture of temperature variation could be more complex. Figure 9 shows a graph of each amplifier station in the TW-fiber link between SP and STUPI. Each station contains amplifiers and dispersion compensation fibers (DCF) of different lengths with no active temperature control. The temperature may differ as much as 10 degrees Celsius over the year, which in turn changes the time delay in the DCFs [12]. This paper will not analyze further the correlation of the TW-fiber link time series with temperature, but it is noted, as in [4], that one of the major error sources of the method is the significant effect due to temperature variations.

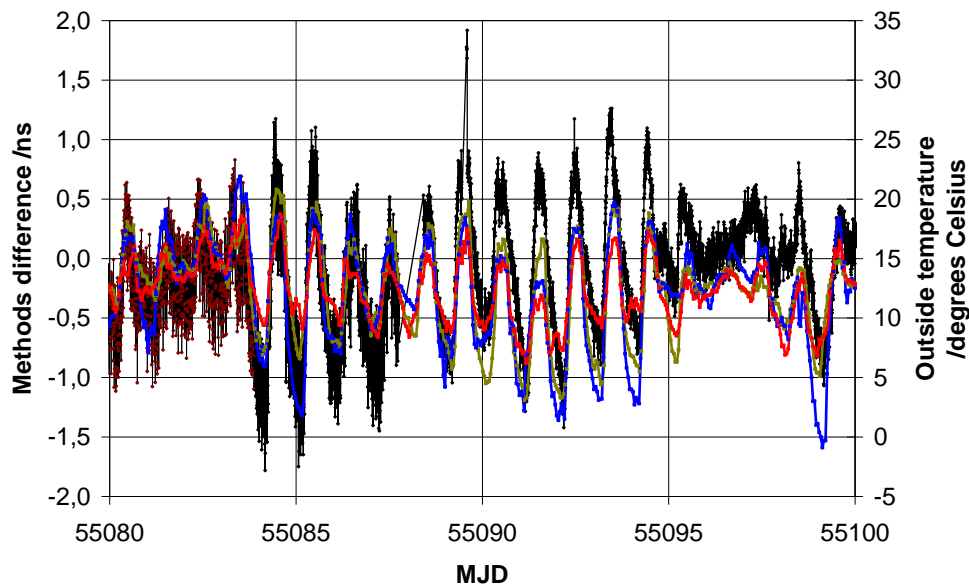

Figure 8. Subset of the data shown in Figure 7 of the method's difference of the two time series shown in Figure 3 (black curve), together with outside temperature data taken (see Figure 9) at SP in Borås (green), at STUPI in Stockholm (blue), and in the city of Örebro (red).

## NEW EQUIPMENT

### PRESENT SYSTEM

As a background to the next subsection, the equipment presently used at the nodes/stations is a combination of custom-made and off-the-shelf products [1]. Figure 10 is a picture of the equipment needed at a single end-node. The vertical space required is more than half of a 19-inch instrumental rack and external cables are needed to connect the different parts of the system, which is a source of error and instability.



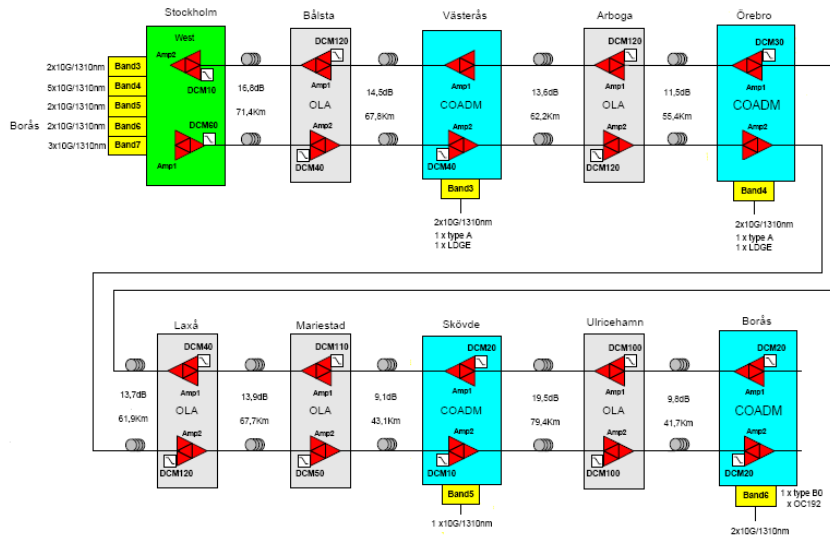

Figure 9. The WDM-network between Stockholm and Borås is a major part of the TW-fiber link between SP and STUPI. The network contains 10 stations with amplifiers and dispersion compensation fibers of different lengths. The differential lengths at each station cause time delay variations of a few nanoseconds due to unstable temperature conditions at the stations.

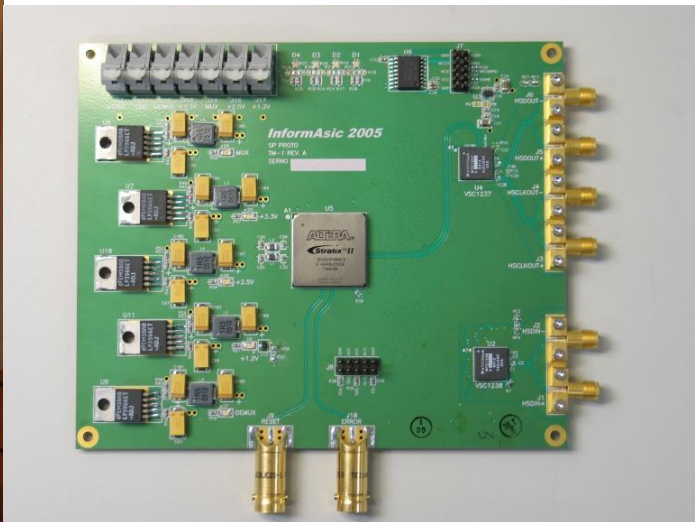

Figure 10. The present system requires several individual pieces of equipment connected by external cables at each node: (to the left) a personal computer with measurement hardware and software at the top; further below two time-interval counters, dual-channel header recognition (HR) box, optical-to-electrical converters, and distribution units for frequency and time pulses at the bottom; (to the right) the custom-made HR-card generates an electrical pulse each time it detects the known sequence of A1 and A2 bytes, and contains a Field Programmable Gate Array (FPGA).

## NEW MODULAR SYSTEM

Present work in the project includes a minimization of the hardware shown in Figure 10 in order to reduce cost, space requirement, power consumption, and ease of installation and use. Important issues are to minimize error sources and improve the robustness and stability of the system. The intention and goal are to make a modular system with space requirements of not more than a 19-inch box with a height and depth not extending 20 cm and 50 cm, respectively.

The modular box will have redundant power supplies supporting -48 VDC and 230 VAC, slots for up to eight individual plug-in cards with dedicated functions, a one-card compact computer module, and a back-plane for distribution of reference signals to each slot. Slots for future functions such as bit-streams generator (see subsection below) and GPS will be available. The outline shown in Figure 11 is an example of functions needed including multi-bit-rates, multi-channel HR-cards with embedded time-stamp/counter modules, temperature sensors, and an oscillator-module containing an internal quartz oscillator. The internal oscillator is intended for use at intermediate stations in the network that do not contain external clocks. The plan is to initiate tests with modular equipment during the first half of the year 2010.

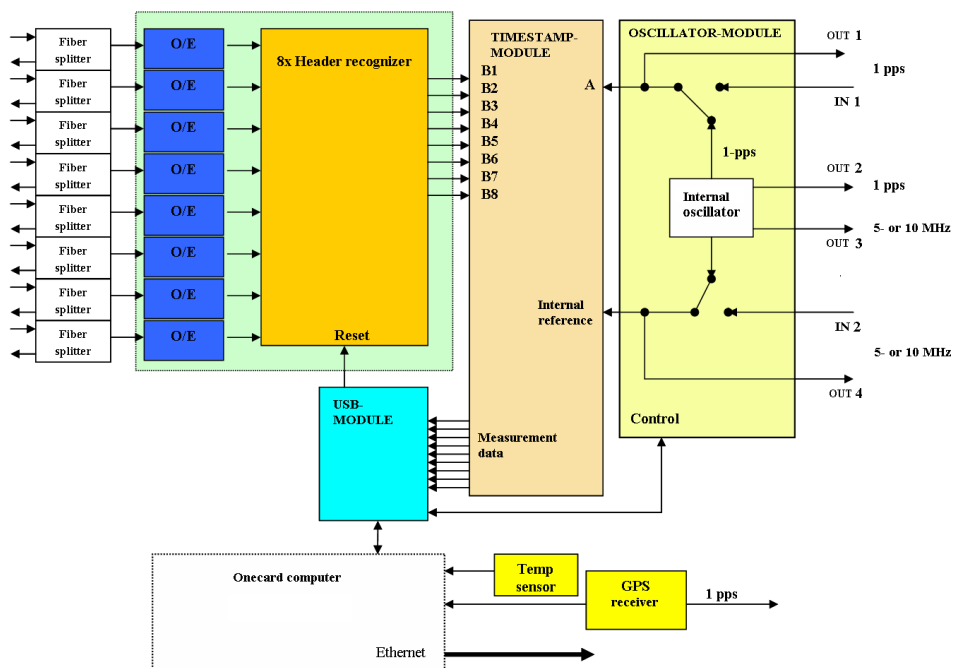

Figure 11. Example of modular functions in new minimized system. The system should have an Internet connection for transfer of measurement data in real time and a capability of storing up to 1 month of data. The data flow internally between slots and plug-in cards is accomplished by some type of serial communication.

## BIT-SEQUENCE GENERATORS

Although departing from the philosophy of passive monitoring, the use of bit-sequence generators in dedicated wavelength slots can be motivated at sites not equipped with core IP routers and SDH transmission possibilities. The generators are preferable constructed for various bit-rates, such as 625 Mbit/s, 2.5 Gbit/s, and 10 Gbit/s.

## USE OF THE PTP PROTOCOL

IEEE 1588 [13-14], PTP (Precision Time Protocol), is a standard for a precision clock synchronization protocol for network measurement and control systems. Parts of the methodology of IEEE 1588 can be used to describe a complete time transfer method using the described two-way measurements on the physical SDH layer. PTP mainly describes a high-level protocol of a complex but deterministic clock synchronization scheme based on two-way time measurements. Precision of a point-to-point time transfer is not limited by the protocol itself, but is dominated by (a) the implementation of the time-stamping and (b) the symmetry of the links. The protocol can handle sub-nanosecond resolutions [14] and is, thus, suitable for metrological timekeeping and time transfer. TW fiber accurately defines message time-stamp points and is capable of resolving local time differences to typically 50 ps, depending on the time-interval counter solution chosen, and asymmetries can be calibrated. The combining of PTP UDP/IP-based packet transport and SDH frame timing can be used to form backbone long-haul precision links, overcoming one major disadvantage of PTP. The use of unicast transport is appropriate. Nodes of the links can autonomously act as boundary clocks both for local PTP distributions as well as time and frequency sources for NTP (see Figure 12).

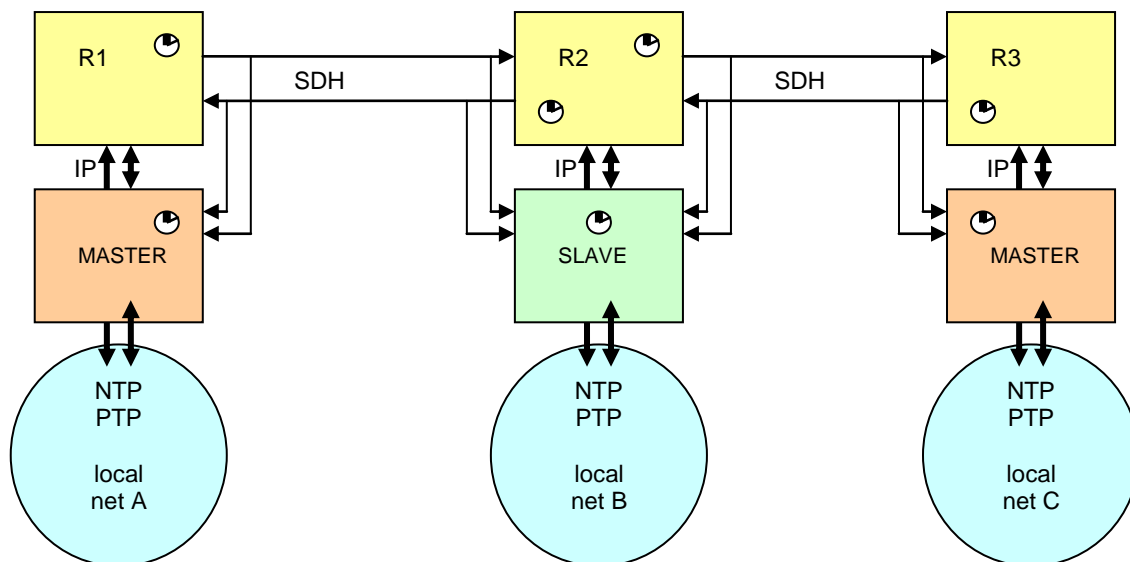

Figure 12. The TW-fiber measurement principle as a physical layer of IEEE 1588. SDH time stamps are used in UDP/IP PTP packets for autonomous timekeeping between the units using the PTP mechanism. PTP Masters are sites with UTC time sources. Slaves can be transparent for end-to-end measurements. All nodes can act as boundary clocks for further distribution using NTP, PTP. Slave sites steer their clocks appropriately in order to keep a close approximation to the master clocks in time and frequency.

## SUMMARY AND CONCLUSION

This paper presented a progress report of the development of a novel method for time and frequency transfer using commercial asynchronous fiber-optic networks. The method is based on passive listening on existing data traffic and the detection of bit sequences in the SDH frame headers continuously transmitted by core IP routers in a packet-over-SONET/SDH OC-192/STM-64 network. A time link between two laboratories in Sweden, operated for more than 1 year in the network OPTOsunet and separated by a network distance of 560 km, shows an RMS agreement with GPS carrier-phase data of less than 1 nanosecond. While the short-term stability of the method is

characterized by white phase noise up to about 1 hour, the stability at 24 hours, as given by the modified Allan deviation, reaches a level of about  $2 \times 10^{-15}$ . There is also significant evidence for daily variations of a few nanoseconds that are correlated with outside temperature and most likely due to differential path delays in amplifiers and dispersion compensation fibers. This effect is one of the major issues to be dealt with in future national and international implementation of the method. An attempt to model the effect was presented in [4]. This paper presented also the work performed for a new minimized modular hardware. The present hardware is a combination of custom-made and off-the-shelf products connected by external cables and requiring a vertical space of half a 19-inch instrumental rack. The new modular hardware is planned to be initially tested during the first half of 2010 and should reduce cost, space requirement, and power consumption, and be improved as to ease of installation and use. Important issues are to minimize error sources such as temperature dependence and improve the robustness and stability of the system.

## ACKNOWLEDGMENTS

This work is supported by the Swedish National Post and Telecom Agency (PTS). SP would like to thank SUNET for their support in this project by giving access to OPTOSunet. The authors would also like to thank National Resources Canada for the NRCan GPS PPP software.

## REFERENCES

- [1] S.-C. Ebenhag, P. Jarlemark, R. Emardson, P. O. Hedekvist, K. Jaldehag, and P. Löthberg, 2008, "Time transfer over a 560 km fiber link," in Proceedings of the 22<sup>nd</sup> European Frequency and Time Forum (EFTF), 23-25 April 2008, Toulouse, France.
- [2] R. Emardson, P. O. Hedekvist, M. Nilsson, S.-C. Ebenhag, K. Jaldehag, P. Jarlemark, C. Rieck, J. Johansson, L. Pendrill, P. Löthberg, and H. Nilsson, 2008, "Time Transfer by Passive Listening over a 10 Gb/s Optical Fiber," **IEEE Transactions on Instrumentation and Measurement**, **IM-57**, 2495-2501.
- [3] S.-C. Ebenhag, K. Jaldehag, P. O. Hedekvist, R. Emardson, P. Jarlemark, C. Rieck, M. Nilsson, J. Johansson, L. Pendrill, P. Löthberg, and H. Nilsson, 2007, "Time transfer using an asynchronous computer network: Results from three weeks of measurements," in Proceedings of the IEEE Intl. Frequency Control Symposium Jointly with the 21<sup>st</sup> European Frequency and Time Forum (EFTF), 29 May-1 June 2007, Geneva, Switzerland.
- [4] S.-C. Ebenhag, P. O. Hedekvist, P. Jarlemark, R. Emardson, K. Jaldehag, C. Rieck, and P. Löthberg, 2009, "Measurement and error sources in Time Transfer using Asynchronous Fiber Network," **IEEE Transactions on Instrumentation and Measurement**, in press.
- [5] S. R. Jefferts, M. Weiss, J. Levine, S. Dilla, and T. E Parker, 1996, "Two-Way Time Transfer through SDH and Sonet Systems," in Proceedings of the 10<sup>th</sup> European Frequency and Time Forum (EFTF), 5-7 March 1996, Brighton, UK, pp. 461-464.
- [6] M. Kihara, A. Imaoka, M. Imae, and K. Imamura, 2001, "Two-Way Time Transfer through 2.4 Gb/s Optical SDH Systems," **IEEE Transactions on Instrumentation and Measurement**, **IM-50**, 709-715.
- [7] J. Ray and K. Senior, 2005, "Geodetic Techniques for Time and Frequency Comparisons using GPS Phase and Code Measurements," **Metrologia**, **42**, 215-232.

- [8] D. Piester, A. Bauch, L. Breakiron, D. Matsakis, B. Blanzano, and O. Koudelka, 2008, “*Time Transfer with Nanosecond Accuracy for the Realization of International Atomic Time,*” **Metrologia**, **45**, 185-198.
- [9] Description of OPTOSunet: <http://basun.sunet.se/engelska.html>
- [10] D. Orgiazzi, P. Tavella, and F. Lahaye, 2005, “*Experimental Assessment of the Time Transfer Capability of Precise Point Positioning (PPP),*” in Proceedings of the Joint IEEE Intl. Frequency Control Symposium and the 36<sup>th</sup> Annual Precise Time and Time Interval (PTTI) Systems and Applications Meeting, Vancouver, British Columbia, Canada (IEEE 05CH37664C), pp. 337-345.
- [11] G. Petit and Z. Jiang, 2008, “*GPS All in View Time Transfer for TAI Computation,*” **Metrologia**, **45**, 35-45.
- [12] A. Andersson, H. Skoogh, S.-E. Ebenhag, and P. O. Hedekvist, 2009, “*Evaluation of Temperature Dependent Transit-Time in Dispersion Compensating Fiber,*” in Proceedings of OFMC Measurement of Optical Fibers and Optoelectronics, 16-18 September 2009, Teddington, UK.
- [13] IEEE Std. 1588TM-2002, SH95023, ISBN 0-7381-3369-8.
- [14] IEEE Std. 1588TM-2008, STDPD95773, ISBN 978-0-7381-5401-5.

