

# PROFICIENCY TESTING ACTIVITIES OF FREQUENCY CALIBRATION LABORATORIES IN TAIWAN, 2009

Huang-Tien Lin, Po-Cheng Chang, Jia-Lun Wang, and Chia-Shu Liao  
National Standard Time & Frequency Lab., TL,  
Chunghwa Telecom Co., Ltd., Taiwan  
12, Lane 551, Min-Tsu Road, Sec. 5, Yang-Mei, Taoyuan, Taiwan 326  
Tel: +886-3-424-4066, Fax: +886-3-424-5474, E-mail: [linht@cht.com.tw](mailto:linht@cht.com.tw)

## Abstract

*In order to meet the requirements of ISO 17025 and the demand of TAF (Taiwan Accreditation Foundation) for calibration inter-laboratory comparisons, the National Time and Frequency Standard Laboratory (TL) [1], playing the role of coordinating lab, has periodically organized the proficiency testing activities to provide opportunities for capability comparisons of domestic frequency calibration laboratories. The latest two activities were performed in 2006 [2] and this year (2009). The “Device under Test” (DUT), together with TL’s calibration system, was transferred to each participating laboratory according to a predetermined schedule. The DUT was measured by the participating lab’s and TL’s calibration systems simultaneously. The measured results from both systems were then analyzed and compared.*

*There were 12 and 15 participating labs joined the activities performed in 2006 and 2009, respectively. All of them were TAF-accredited laboratories. As usual, the  $E_n$  value was used to evaluate a lab’s capability of calibrating equipment within its accredited measurement uncertainty.*

*In these two activities, the absolute  $E_n$  values of all labs were smaller than “1,” which means their calibration ability was completely qualified. In this paper, the related details of these two activity and the result comparisons between activities in 2006 and 2009 are illustrated.*

## INTRODUCTION

The goal of performing the proficiency testing activity is to provide a chance for the domestic accredited laboratories to compare their calibration capability with one another. When performing on-site evaluation, an assessment team is organized to examine the technical competence of the labs and their compliance with the requirements of ISO/IEC 17025 *General requirements for the competence of testing and calibration laboratories*. The proficiency testing results are then important information for the technical assessment team to evaluate the ability of the laboratory.

In proficiency testing activities [3,4], the ability of each individual laboratory is supposed to be determined and able to achieve its accredited level of measurement uncertainty. In the case that the performance of the “Device under Test” (DUT) has good repeatability and stability, its reference value

will be assigned by the coordinating lab and then compared with measurement results of the participating labs, as shown in Fig 1. When the reference value is located within a lab's uncertainty range (e.g., lab 1, 2, and 3 in Fig.1), we say that this lab works within its capability and its accredited level of measurement uncertainty is suitable for the DUT being calibrated.

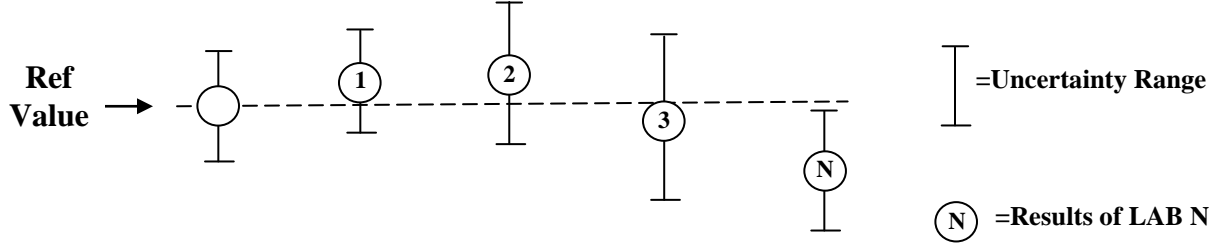

Fig. 1. Measurement results and uncertainty ranges of participating labs.

However, the characteristic of the DUT in the time/frequency area (such as a frequency oscillator) is non-stationary, so the reference value may change gradually. Therefore, together with the DUT, a calibration system of the coordinating lab is usually transferred to each participant laboratory to get the relative reference value simultaneously with the measurement. In other words, the DUT is measured by the participant's and the coordinating lab's calibration systems at the same time.

## EVALUATION OF RESULTS

In the proficiency test activities among calibration laboratories, the  $E_n$  value is adopted to indicate how well labs are within their particular measurement uncertainty, taking account of the measurement uncertainty of the reference value.  $E_n$  stands for Error normalized and is defined as:

$$E_n = \frac{X_i - X_{ref}}{\sqrt{U_{95}^2(X_i) + U_{95}^2(X_{ref})}} \quad (1)$$

where  $X_i$  is the participant laboratory's result

$X_{ref}$  is the coordinating laboratory's result

$U_{95}(X_i)$  is the participating laboratory's reported uncertainty (95%)

$U_{95}(X_{ref})$  is the coordinating laboratory's reported uncertainty (95%)

$|E_n| \leq 1$  indicates that the result and the reference value are in agreement

$|E_n| > 1$  indicates that the result is different from the reference value.

Note that the calculation of  $E_n$  value does not intend to indicate which lab's result is closest to the reference value, as high-level calibration labs may have their  $E_n$  values similar to that of some other labs with both larger measurement errors and uncertainties.

Besides, one should be aware that the reference value itself has a measurement uncertainty. The coordinating lab should have the capability to give a better measurement uncertainty than the participating lab's; otherwise, it will be difficult to evaluate each lab's performance. Consequently, the  $|E_n| \leq 1$  limit really only represents the cutoff, below which it is likely that the result is acceptable and above which it is

unlikely that the result is acceptable. So when considering any result with  $|E_n|$  greater than 1, all factors should be evaluated to see if there is a systematic bias that is consistently positive or consistently negative which causes the problem.

## PROFICIENCY TESTING ACTIVITY

TL, playing the role of coordinating lab, has periodically organized the proficiency testing activities every 3 years since 2003. The latest two activities were performed in 2006 and 2009, with HP8662A [5] and HP33250A frequency synthesizers as the DUT, respectively. Both HP8662A and HP33250A can offer 5/10 MHz output signals, so any laboratory with a calibration capability for either 5 MHz or 10 MHz can join these activities. The aging rate of HP8662A is smaller than  $5.0 \times 10^{-10}$ /day, which is lower than that of HP33250A, which is about  $5.5 \times 10^{-9}$ /day.

Since the properties of an oscillator's signal are non-stationary, TL's calibration system, consisting of a 5071A cesium clock, a SR620 time-interval counter, and a recording computer along with the DUT, were sent to each participating lab sequentially. The DUT's reference value can then be obtained during the measurement process in each lab. The above mentioned 5071A cesium clock is TL's portable frequency reference, which is traceable to the national frequency standard. To make sure that the HP5071A can satisfy the requirement of traceability, the performance of this Cs clock was measured in TL before and after every measurement trip to the participating labs. The block diagram of the related system for the proficiency testing activities is shown in Fig. 2.

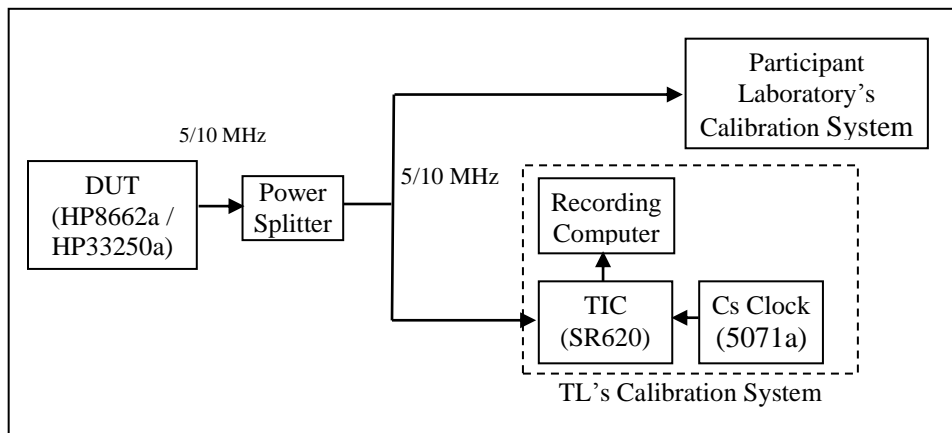

Fig. 2. The system arrangement in proficiency testing activities.

The number of participating labs that joined the proficiency testing activities was 12 in 2006 and increased to 15 in 2009, but the same procedure was followed. Before the measurement trips to the participating labs in each activity, an opening meeting was held in advance to discuss all details about the related activities. A consensus referring to the schedule for transferring the DUT and TL's calibration system, the measurement method, the uncertainty evaluation, the result expression, etc. was reached. Since 2006, TL has recommended that the participating labs include the best measurement capability of the individual lab, the DUT's aging rate and temperature effects, etc. in their uncertainty budgets.

Note that, in general calibration services, an uncertainty budget usually included the DUT's aging to assure the validity of the measurement result during the period that the DUT returned to its lab till the next time the DUT was sent for calibration. However, it isn't necessary to count the aging for a long period (for example, 1 year) in proficiency testing activities, because the DUT only serves as an intermediate for proficiency testing comparisons and the measurement time in each participating labs is not longer than 1 hour. Therefore, we announced DUT's aging rate for 1 day to each participating lab for their evaluation of measurement uncertainty. While finishing the measurement, each participating lab was required to send its test report, raw measurement data, and uncertainty budget to TL within 3 days.

After the measurement trips to the participating labs, collecting the measurement data and evaluating the capability of each laboratory, a meeting was held for final discussion and providing the chance for face-to-face communication with the participant labs.

## RESULTS ANALYSIS AND CONCLUSION

The proficiency testing results of 12 participating labs in 2006 and 15 participating labs in this year are shown in Tables 1 and 2, respectively.  $X_i$ ,  $X_{ref}$ ,  $U_{95}(X_i)$  and  $U_{95}(X_{ref})$  stand for the corresponding measurement results (frequency accuracy) and reported uncertainties from participating labs and TL. Using these four parameters, the  $E_n$  value of each participating lab could be obtained.

Considering a drifting frequency standard may influence the measurement result, it is reasonable for participant labs to include the latest calibrated accuracy of their individual frequency standards in the  $X_i$  measurements, or separately specify both of them in each participant lab's test report. Results of the latter are adopted in Table 1 and the mentioned calibrated accuracy  $\Delta X_i$  can be used for the  $E_n$  correction.

The corrected  $E_n$  value could be obtained using equation as below:

$$E_n = \frac{(X_i + \Delta X_i) - X_{ref}}{\sqrt{U_{95}^2(X_i) + U_{95}^2(X_{ref})}}. \quad (2)$$

Besides, adjustment of  $X_{ref}$  is negligible because the calibrated accuracy of TL's portable frequency reference can reach  $1.5 \times 10^{-13}$ , about 4 orders lower than the magnitude of  $X_{ref}$  itself.

For most of the participants in Table 1, the corrected  $|E_n|$  are smaller than or equal to the original ones. This shows that the  $E_n$  correction is meaningful, which gives more reasonable results for inter-laboratory comparisons. Equation (2) can also be considered as the corrected measurement difference between a participating lab and TL, divided by their combined uncertainty.

In general,  $U_{95}(X_i)$  is the dominant term in the combined uncertainty, so the corrected  $|E_n|$  is a good index to show how well a participating lab is within its accredited capability. All the corrected  $|E_n|$  of 12 participating labs in 2006 and 15 participating labs this year are smaller than "1," which indicates that the calibration capabilities of all the participants are qualified in these two activities.

Moreover, one may found that most of the corrected  $|E_n|$  values in Table 2 are smaller than those in Table 1. This is caused by the performances of different DUTs adopted in these two activities. The aging rate and temperature coefficient of an HP33520A (DUT of 2009) are larger than those of an HP8662A (DUT

of 2006), so the combined uncertainties are commonly larger and the correspondent  $|E_n|$  values become smaller. Generally speaking, a DUT with smaller aging and temperature coefficient would be more suitable for the proficiency testing application, and the capability of the participating labs can be more properly evaluated.

## REFERENCES

- [1] H. T. Lin, C. S. Liao, S. Y. Lin, W. H. Tseng, C. C. Lin, P. C. Chang, D. Wang, F. D. Chu, and H. Shyu, “Highlights of the 2008 activities of the National Time and Frequency Standard Laboratory of the Telecommunication Laboratories, CHT CO. LTD., Taiwan,” in Proceedings of the Asia-Pacific Workshop on Time and Frequency (ATF), 30 October-1 November 2008, Jakarta, Indonesia.
- [2] P. C. Chang, H. T. Lin, and C. S. Liao, “Proficiency testing activities of frequency calibration laboratories in Taiwan, 2006,” in Proceedings of the Asia-Pacific Workshop on Time and Frequency (ATF), December 2006, New Delhi, India.
- [3] NATA Proficiency Testing Training Course.
- [4] Guide to the Expression of Uncertainty in Measurement (ISO), 1995.
- [5] HP 8662A Synthesized Signal Generator Operating and Services Manual, Sec. 1 (Hewlett-Packard), pp. 4-9.

Table 1. Proficiency testing results of 12 participating labs.

Report No.	$X_i$	$X_{ref}$	$\Delta X_i$	$U_{95}(X_i)$	$U_{95}(X_{ref})$	$ E_n $	$ E_n (\text{corrected})$
TL-PT2-01	-3.0343E-09	-4.30E-09	-2.6E-10	1.19E-09	3.76E-10	1.01	0.81
TL-PT2-02	-3.8000E-09	-3.70E-09	6.4E-12	4.10E-10	4.68E-10	0.16	0.15
TL-PT2-03	2.5507E-09	3.00E-09	3.2E-10	7.32E-10	3.76E-10	0.55	0.16
TL-PT2-04	-1.0000E-08	-4.30E-09	3.3E-11	5.82E-09	6.83E-10	0.97	0.97
TL-PT2-05	-3.0800E-09	-2.90E-09	-1.9E-13	6.18E-09	3.08E-10	0.03	0.03
TL-PT2-06	-4.5250E-09	-5.50E-09	-1.0E-09	3.16E-09	3.76E-10	0.31	0.01
TL-PT2-07	-4.4500E-08	-1.40E-09	9.3E-09	8.96E-08	4.68E-10	0.48	0.38
TL-PT2-08	-4.6000E-09	-4.90E-09	1.3E-10	9.00E-10	3.76E-10	0.31	0.44
TL-PT2-09	-2.3400E-09	-1.60E-09	1.4E-10	9.13E-10	3.38E-10	0.76	0.62
TL-PT2-10	-3.6330E-09	-3.30E-09	1.5E-12	5.05E-10	3.76E-10	0.53	0.53
TL-PT2-11	-5.6900E-09	-4.74E-09	-7.6E-11	9.20E-08	3.76E-10	0.01	0.01
TL-PT2-12	-3.0000E-09	-2.10E-09	-3.2E-10	3.30E-07	3.76E-10	0.01	0.01

Table 2. Proficiency testing results of 15 participating labs.

Report No.	$X_i$	$X_{ref}$	$\Delta X_i$	$U_{95}(X_i)$	$U_{95}(X_{ref})$	En  (corrected)
TL-98FMPT-01	-4.918564E-07	-4.92345E-07	-1.70E-13	7.571E-08	6.93E-08	0.005
TL-98FMPT-02	-3.177987E-07	-3.17600E-07	-1.40E-11	1.500E-07	6.93E-08	0.001
TL-98FMPT-03	-3.841748E-07	-4.23000E-07	3.20E-08	1.500E-06	6.93E-08	0.005
TL-98FMPT-04	-4.115972E-07	-4.11000E-07	-2.40E-10	4.900E-07	6.93E-08	0.001
TL-98FMPT-05	-5.097840E-07	-5.10000E-07	1.45E-10	4.200E-07	6.93E-08	0.001
TL-98FMPT-06	-3.260692E-07	-3.20000E-07	3.70E-10	1.400E-07	6.93E-08	0.041
TL-98FMPT-07	-4.194414E-07	-4.21000E-07	8.10E-11	3.300E-07	6.93E-08	0.004
TL-98FMPT-08	1.112796E-08	1.11000E-08	-1.50E-13	4.300E-08	6.93E-08	0.001
TL-98FMPT-09	-5.255941E-07	-5.25000E-07	-5.00E-10	1.400E-07	6.93E-08	0.001
TL-98FMPT-10	-4.964631E-07	-4.96185E-07	1.50E-10	1.200E-06	6.93E-08	0.001
TL-98FMPT-11	-3.686349E-07	-3.68000E-07	-1.20E-09	1.390E-07	6.93E-08	0.004
TL-98FMPT-12	-3.432065E-07	-3.42923E-07	-1.00E-12	1.390E-07	6.93E-08	0.002
TL-98FMPT-13	-3.316300E-07	-3.37000E-07	6.50E-09	2.200E-07	6.93E-08	0.005
TL-98FMPT-14	-3.299086E-07	-3.30000E-07	9.90E-11	6.820E-08	6.93E-08	0.001
TL-98FMPT-15	-3.656232E-07	-3.94400E-07	6.00E-10	6.820E-08	6.93E-08	0.29