

TIME STABILITY AND ELECTRICAL DELAY COMPARISON OF DUAL- FREQUENCY GPS RECEIVERS

A. Proia^{1,2}, G. Cibiel¹, and L. Yaigre³

¹Centre National d'Etudes Spatiales

18 Avenue Edouard Belin, 31401 Toulouse, France

Tel: 0335.61.27.37.86.

E-mail: *amandine.proia@cnes.fr*

²Bureau International des Poids et Mesures, Sèvres, France

³Sogeti High-Tech, Toulouse, France

Abstract

Some dual-frequency GPS receivers have been used for time comparisons for several years. They are now standard equipment for operational units in time laboratories. Evaluation of these receivers is necessary to ensure accuracy and long-term stability of time links used in TAI and in precise time station (PTS) dedicated to GALILEO. Currently, the most widely approach used to determine the electrical delay and the time stability of these devices is the differential method developed by the BIPM.

Another solution is the calibration and the evaluation of receivers in using an artificial signal simulated by a GNSS signal simulator. This method was first defined and performed by Colorado University and put into operations by the Naval Research Laboratory (NRL). Since 2005, CNES (French Space Agency) has been developing this method with a similar approach.

CNES proposed an evaluation and a calibration of three types of these time receivers, Ashtech Z12-T, Septentrio PolaRx2, and Dicom GTR50, in using the simulated method.

I. INTRODUCTION

Global Navigation Satellite System (GNSS) time and frequency transfer is among the most useful tools for comparison of remote clocks. It represents the basis of the time laboratories contributions for the realization of Temps Atomique International (TAI) [1]. These comparisons are carried out with dual frequency P-code GPS receivers, which must be evaluated periodically to ensure the accuracy and long-term stability of time links. Presently, several receiver models are available and used in time laboratories, such as Ashtech Z12-T, Septentrio PolaRx2, Dicom GTR50, or TTS03.

The usual approach to evaluate or calibrate a receiver consists of working on natural reception, i.e. using a GNSS reception chain (antenna, cable antenna, and receiver). A widely used approach to perform this experiment is the differential calibration developed by BIPM [2]: GNSS equipment is designated as the reference and is in constant circulation among time laboratories. A relative calibration is performed between this piece of equipment and the laboratory equipment.

This paper proposes the alternative of replacing natural reception by artificial reception from a GNSS signal simulator (GSS). Up to now, this approach was only used to calibrate the receiver. This

calibration method was first defined and used by Colorado University and put into operations by the Naval Research Laboratory [3]. Since 2005, CNES has been developing this method with a similar approach [4].

This paper is focused on the evaluation and the calibration of some different receivers in using the artificial reception approach.

Section II presents geodetic receivers and describes their characteristics. Seven receivers, two Ashtech Z12-T receivers, two Septentrio PolaRx2 receivers, and three Dicom GTR50 receivers were investigated. The method used to evaluate and calibrate the receivers is described in Section III. The time stability measurement of the receivers is presented in Section IV. Finally, Section V is dedicated to receivers' electrical delay and their uncertainties.

II. RECEIVERS

Geodetic GPS receivers used for time transfer are characterized by two features:

- a. The receiver internal clock is driven by an external frequency provided by the laboratory
- b. The receiver has a 1 Pulse per Second (1PPS) input that allows to define an “internal reference” from the internal clock.

The precise definition of the internal reference depends on the receiver model. Ashtech Z12-T, Septentrio PolaRx2, or Dicom GTR50 receivers fulfill both criteria

The delay between the 1PPS input and the internal reference will be referred as $R_{X_{1PPS}}$. This value is specific to every kind of receiver and depends on the electronic architecture of the equipment and is generally defined by the supplier. The output data must be corrected for this bias to be referenced to the internal system clock.

1. ASHTECH Z12-T

The Ashtech Z12-T receiver performs pseudo-range and carrier-phase measurements that are referred to an “internal reference” derived from a 20-MHz external signal [5]. The 1PPS external signal allows the receiver to choose one particular cycle of the 20 MHz to form the internal reference. This operation allows one to guarantee the repeatability of this reference in case of interruption of the tracking or operation of the receiver. The internal reference is then defined as the first positive zero-crossing of the 20 MHz in following the rising tick of the 1PPS-in signal [6]. The delay between the 1PPS signal and the 20-MHz signal ($R_{X_{1PPS}} : TtP$) is measured with a digital oscilloscope. By direct measurement on the oscilloscope display, it is possible to determine the relative phase of the two signals.

The Ashtech Z12-T is no more commercially available since 2005.

2. SEPTENTRIO POLARX2

The Septentrio PolaRx2 receiver provides dual-frequency tracking of the GPS signal and simultaneous tracking of up to six Space-Based Augmentation System (SBAS) satellites [5]. The receiver accepts a 10-MHz external frequency and an associated 1PPS input. As for the Ashtech receiver, the Septentrio internal time scale is synchronized to the 1PPS signal, providing repeatability of this reference. The receiver synchronizes its measurement latching with the first low-to-high transition it detects on the 1PPS input connector. The delay between a low-to-high transition on the 1PPS input connector and the latching of the measurements in the receiver is between 221.7 and 255 ns (± 2 ns). The exact delay depends on the phase relationship between the 10-MHz frequency

reference and the 1PPS input signal ($R_{X_{1PPS}} : X_0$). This delay is constant and is insensitive to powering off and on the receiver. In order to measure the delay between the 1PPS input pulse and the measurement latching, it is possible to synchronize the 1PPS output signal from the receiver with the measurement-latching epoch. The constant offset between the 1PPS output and the measurement latching is indicated in Septentrio PolaRx2's documentation: "*measurement latching*" = "*Output 1PPS*" plus 8.7 ns (for firmware version 2.3 and higher). Thus, by measuring the delay from the 1PPS input to the 1PPS output, we have access to the internal reference that we have defined.

3. DICOM GTR50

The GTR50 receiver is a Linux PC with a GPS board and a time-interval counter all together in a 19" chassis. The time-interval counter and the GPS board are located in a thermostated box (a fan maintains air circulation in the box) to minimize their temperature drift. The temperature is 45°C with a maximum deviation of 1°C. The Javad GPS board supports both code and phase measurements. The internal quartz oscillator is the source of the 1PPS output synchronized to GPS Time. The time difference between the 1PPS external signal and this internal time base ($R_{X_{1PPS}}$) is collected like the receiver measurement data (pseudo-ranges and phase measurements to individual satellites) in hourly files. Contrary to the previous receivers, no 1 PPS internal delay is considered and all the output data (RINEX, CGGTTS, L3P, RAW) are referenced to the external 1PPS. Five calibration delays (antenna cable delay, 1PPS delay, C1 receiver delay, P1-C1 receiver differential delay, and P1-P2 receiver differential delay) are applied to all output data to keep data in all these formats fully consistent. The antenna cable delay and the 1PPS delay can be changed from the Web user interface. The receiver internal delay and the P1-C1 and P1-P2 differential delays can be cancelled contrary to the $R_{X_{1PPS}}$, of which the correction is automatically applied at each acquisition.

The current version of the GTR50 does not require an external 10-MHz reference. Indeed, the time-interval counter uses an internal frequency reference which is continuously calibrated with respect to GPS time.

In this present work, all bias corrections are equal to zero except the $R_{X_{1PPS}}$ value.

III. EVALUATION AND CALIBRATION METHOD

The CNES approach consists in an artificial reception free of delays, effects, and noises upstream at the output of antenna: atmospheric delays (troposphere and ionosphere), multipath effects or antenna delay, ... This condition can be conducted with a GNSS signal simulator (Figure 1). The GSS used is a Spirent STR4760. It generates pseudo-range code signals on both L1 and L2 frequencies (four channels in L1 and 4 channels in L2).

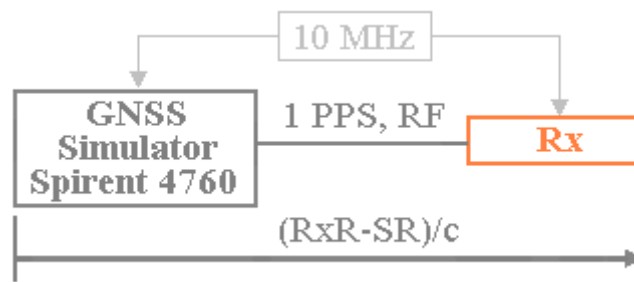

Figure 1. Schematic of artificial reception method.

The time deviation of the pseudo-distances between the simulator and the receiver allows the determination of the time stability of the receiver, i.e. the specific performance of the receiver.

Figure 2 presents a schematic of receiver absolute calibration. This calibration method was first defined and used by Colorado University and put into operation by the Naval Research Laboratory [3]. Since 2005, CNES has been developing this method with a similar approach [4].

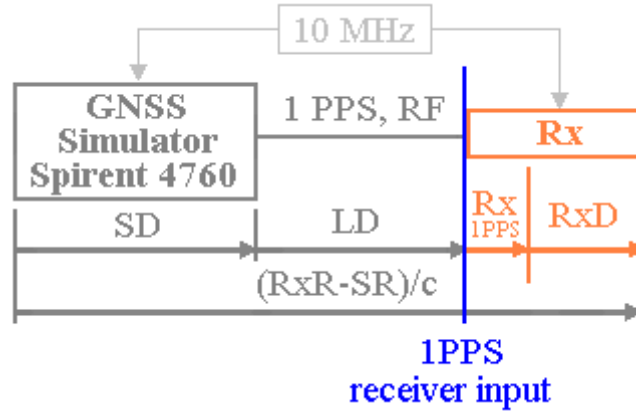

Figure 2. Schematic of receiver absolute calibration.

This fixed relationship allows the receiver delay calculation. The internal electrical time delay of the receiver is calculated thanks to Equation 1:

$$RxR - SR = c \cdot LD + c \cdot SD + Rx_{1PPS} + RxR - SR + RxR - SR \quad (\text{Eq. 1})$$

where:

- RxR-SR: Difference of receiver and simulator pseudo-ranges
- c: Light celerity
- LD: 1 PPS and RF links delays difference ($LD_{RF} - LD_{1PPS}$)
- SD: Simulator delay
- Rx_{1PPS} : Time delay between the receiver internal reference and the external 1 PPS.

During the calibration measurement, due to their temperature sensitivity [4], the simulator and the receivers were located in a temperature-regulated room at 20°C with a maximum deviation of ±1°C.

IV. TIME STABILITY

The receiver time stability is the time deviation of the pseudo-ranges acquisition in nanoseconds. Figure 3 shows the results obtained for the P1-code and P2-code of a Septentrio receiver.

A half-day term degrades the time deviation. Indeed, the Spirent simulator is very sensitive to the temperature fluctuations, and this phenomenon makes impossible the evaluation of the long-term stability of receivers. A pseudo-range scattering estimated to be up to 0.4 ns/°C was already noted [4].

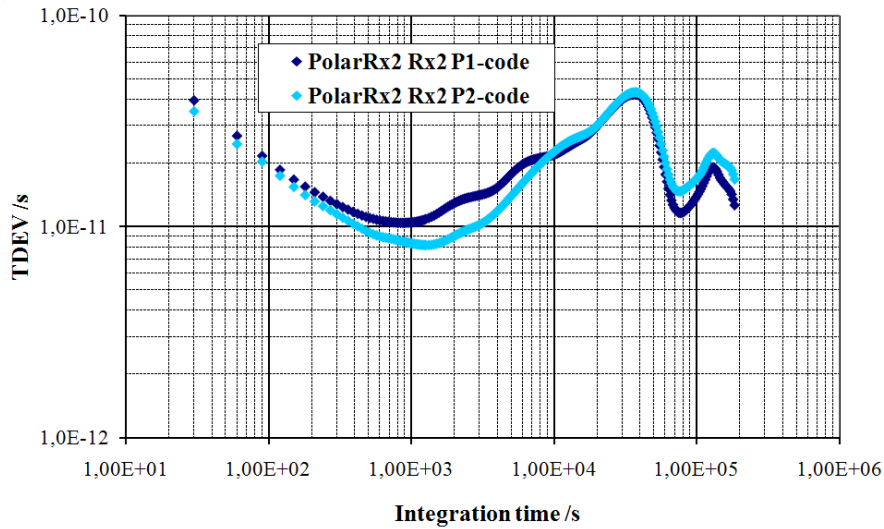

Figure 3. Tdev of the P1-code and P2-code of the PolaRx2 Rx2.

In order to take into account this problem, two similar receivers simultaneously get the simulator signal (Figure 4), so that the output data difference allows cancellation of the pseudo-range fluctuations.

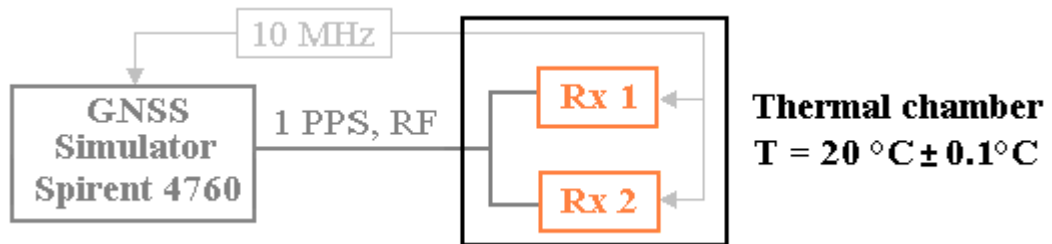

Figure 4. Schematic of time stability measurement with GSS thermal sensitivity cancellation.

The simulator was located in a temperature-regulated room at 20°C with a maximum deviation of 1°C and the receivers were placed in a thermal chamber where the temperature is regulated to 20°C ± 0.1°C. A pair of Ashtech and Septentrio receivers was placed in this configuration to be evaluated. The Dicom GTR50 receivers are too voluminous to be completely placed in the thermal chamber. The box was then not closed hermetically and the thermal regulation was less efficient.

At each acquisition, the pseudo-range average for all the satellites in view is calculated. This operation is performed for every receiver pair. The P1-code pseudo-ranges for the PolarRx2 Rx1 and the PolarRx2 Rx2 are presented in Figure 5.

It can be noted that the thermal sensitivity of the simulator is visible in the pseudo-ranges and is about 0.5 ns/°C at a temperature of 21°C, in agreement with [4].

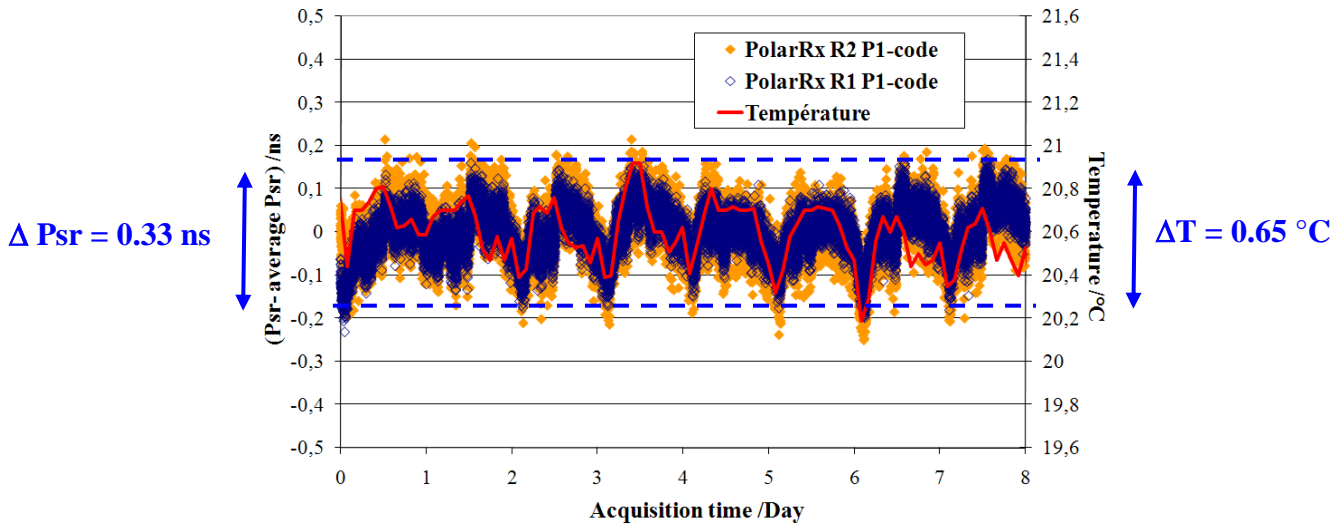

Figure 5. Pseudo-ranges of P1-code for the PolarRx2 Rx1 and the PolarRx R2.

The pseudo-range differencing of each receiver pair is performed to evaluate the time stability of the different equipment. Figure 6 illustrates the time deviation of the P1 and P2 code difference of each kind of receiver for a 6-day acquisition duration.

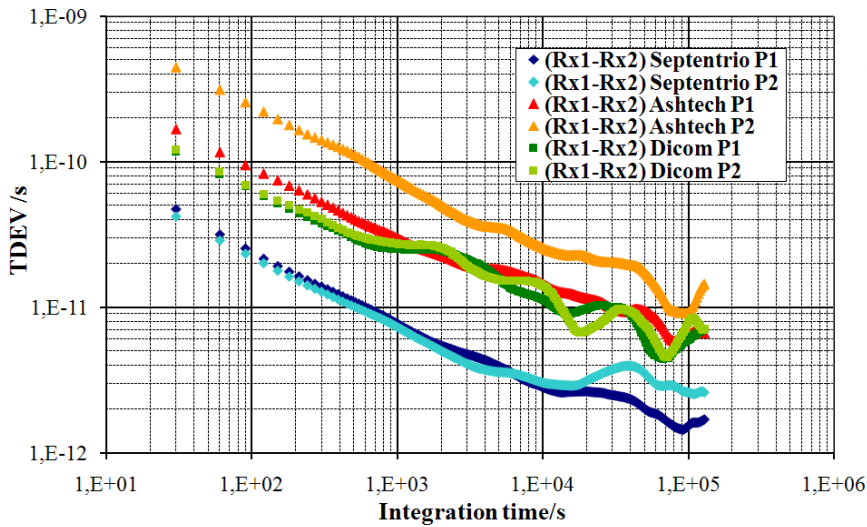

Figure 6. Time deviation of the P-code difference.

The Dicom receivers suffer from a periodic term. These devices also contain Linux PCs, which eject hot air. In this condition, the thermal chamber cannot regulate the temperature with precision and the pseudo-range acquisition differs with the temperature.

In this setup, the total time stabilities of the P-code difference presented in Figure 6 are the quadratic sum of the time stability of each receiver (Rx1 & Rx2). In the case of Ashtech receivers, the time stability of both receivers is equivalent and corresponds to the total stability divided by $\sqrt{2}$. In the case of Septentrio and Dicom receivers, the time stabilities of both receivers are not equivalent and the total time stability is imposed by the worst receiver time stability.

The table 1 resumes the short term (at 30 s) and long term (at one day) stability of the receivers:

Table 1. Receiver time stability.

Receiver	Short-term Stability 30s (ps)		Long-term Stability 1 day (ps)	
	L1	L2	L1	L2
Ashtech Z12-T	168.30	445.70	6.09	9.30
Septentrio PolaRx2	47.16	42.26	1.48	2.79
Dicom GTR50	118.30	121.80	5.42	6.08

The Septentrio receiver has the best stability: between 40 ps and 50 ps in the short term and below 3 ps in the long term. The short-term stability of P1 and P2 code are close for the Septentrio and Dicom receivers, contrary to the Ashtech, which shows an important difference of about 300 ps.

V. RECEIVER TIME DELAY

Six receivers have been absolute calibrated: two Dicom GTR50 receivers, two Ashtech Z12-T receivers, and two Septentrio PolaRx2 receivers. The GTR50 receiver measurements were performed to cancel all the bias corrections except the RX_{1PPS} . Table 2 presents L1 and L2 electrical delay of each receiver and their uncertainties for 1 sigma.

Table 2. L1 and L2 time delay of each receiver and uncertainties for $\sigma=1$.

Time Delay		P1 (ns)	P1 Uncertainty (ns) $\sigma=1$	P2 (ns)	P2 Uncertainty (ns) $\sigma=1$	[P2-P1] (ns)
Ashtech Z-12 T	<i>CNES Rx</i>	284.49	0.39	290.71	0.40	6.22
	<i>OP Rx</i>	286.11	0.41	302.58	0.40	16.47
Septentrio PolaRx2	<i>CNES Rx1</i>	192.12	0.43	190.92	0.43	-1.20
	<i>CNES Rx2</i>	192.72	0.43	193.26	0.43	0.54
Dicom GTR50	<i>BIPM Rx</i>	-96.66	0.37	-110.11	0.37	-13.45
	<i>PTB Rx</i>	-28.41	0.37	-34.91	0.37	-6.50

The only changing parameters according to the receiver used are the RX_{1PPS} measurement and the pseudo-range measurement. The calibration uncertainties are of the same order of magnitude: about 0.4 ns/°C, because the error budget is dominated by the pseudo-range error of the simulator (0.33 ns).

The [P2-P1] differential delays are not constant for the same kind of receiver. This difference is due to various manufactured versions of receivers.

The results of the Dicom receivers are negative because the RX_{1PPS} correction is systematically applied to the output data. Indeed, the RX_{1PPS} has an opposite sign to the internal receiver delays and the magnitude of this bias is more important than the P1 and P2 internal receiver delays.

Determination of Dicom GTR50 Receivers:

Dicom performs a differential calibration of GTR50 receivers to define the C1 delay, the P1-C1 differential delay, and the P1-P2 differential delay. These biases, the antenna delay, the 1PPS delay, and the Rx_{1PPS} value are corrected in all the output data by the receiver. The uncertainty of this Dicom calibration is unknown.

To compare the Dicom and CNES calibrations, the CNES measurements were performed to cancel all the bias corrections except the Rx_{1PPS} value.

The Table 3 presents the difference between the CNES calibration and the Dicom calibration for the CNES GTR50, the PTB GTR50, and the BIPM GTR50. The CNES calibration has an uncertainty below 0.4 ns ($k=1$).

Table 3. Dicom and CNES calibration of GTR50 receivers.

Receiver		CNES Rx		PTB Rx		BIPM Rx	
Delay		Values (ns)	Diff. (ns)	Values (ns)	Diff. (ns)	Values (ns)	Diff. (ns)
C1	DICOM	-33.60	0.20	-26.80	0.37	-95.37	0.33
	CNES	-33.40		-26.43		-95.04	
P1-C1	DICOM	-4.50	0.00	-2.00	0.01	-1.69	0.07
	CNES	-4.50		-1.99		-1.62	
P1-P2	DICOM	-14.80	0.10	-6.18	-0.29	-12.98	-0.47
	CNES	-14.70		-6.47		-13.45	

The CNES and Dicom calibrations of the GTR50 receivers give very close results: the difference is below 0.5 ns. This result is quite impressive, but for the moment Dicom did not give more information on this subject.

V. CONCLUSION

A method that uses a GNSS hardware simulator is now proven. It allows one to determine the electrical delay of most of geodetic receivers used in time laboratories: Ashtech Z12-T, Septentrio PolaRx2, and Dicom GTR50, with an uncertainty of about 0.4 ns. This error budget could be reduced if the simulator uncertainty was not the dominant element.

The comparison between the CNES and Dicom calibrations of the GTR50 receivers shows a very weak difference of the same order of magnitude to the absolute calibration uncertainty.

A performance comparison of three receivers was also performed. The simulator is very sensitive to the temperature fluctuations (about 0.4 ns/°C). In order to limit this problem, two similar receivers simultaneously get the simulator signal. The output data difference allows the cancellation of the pseudo-range fluctuations. At each acquisition, the pseudo-range average for all the satellites in view is calculated.

It also allows one to define the true time stability of the receiver by calculating the time deviation of the pseudo-range difference. The daily stabilities of receivers for L1 and L2 are:

- Ashtech Z12-T: L1 = 6.09 ps, L2 = 9.30 ps

- Septentrio PolaRx2: L1 = 1.48 ps, L2 = 2.79 ps
- Dicom GRT50: L1 = 3 ps, L2 = 3 ps.

The Septentrio receiver has the best short- and long-term stability. The short-term stability of P1 and P2 code is of the same order of magnitude for the Septentrio and Dicom receivers when the Ashtech shows an important difference of about 300 ps.

In the future, the aim will be to extend this investigation as whole the GNSS reception chain, the receiver but also the antenna cable and the antenna.

VI. ACKNOWLEDGMENTS

The authors particularly thank G. Petit from BIPM and A. Bauch and T. Feldmann from PTB for helpful discussions, and the OP time transfer department and the T2L2 CNES mission for lending equipment. They also thank Dicom for technical support.

VII. REFERENCES

- [1] C. Bruyninx, P. Defraigne, J.-M. Sleewaegen, and P. Paquet, 1999, “*Frequency Transfer using GPS: A Comparative Study of Code and Carrier Phase Analysis Results*,” in Proceedings of the 30th Annual Precise Time and Time Interval (PTTI) Systems and Applications Meeting, 1-3 December 1998, Reston, Virginia, USA (U.S. Naval Observatory, Washington, D.C.), pp. 307-314.
- [2] G. Petit, Z. Jiang, P. Uhlich, and F. Taris, 2000, “*Differential calibration of Ashtech Z-12T receiver for accurate time comparisons*,” in Proceedings of the 14th European Frequency and Time Forum (EFTF), 14-16 March 2000, Turin, Italy, pp. 40-44.
- [3] J. White, R. Beard, G. Landis, G. Petit, and E. Powers, 2001, “*Dual frequency absolute calibration of a geodetic GPS receiver for time transfer*,” in Proceedings of the 15th European Frequency and Time Forum (EFTF), March 2001, Neuchâtel, Switzerland, pp. 167-172.
- [4] G. Cibiél, A. Proia, L. Yaigre, J.-F. Dutrey, A. de Latour., and J. Dantepal, 2008, “*Absolute calibration of geodetic receivers for time transfer: Electrical delay measurement, uncertainties and sensitivities*,” in Proceedings of the 22nd European Frequency and Time Forum (EFTF)/European Navigation Conference (ENC), 23-25 April 2008, Toulouse, France.
- [5] G. Petit, P. Defraigne, B. Warrington, and P. Uhlich, 2006, “*Calibration of dual frequency GPS receivers for TAI*,” in Proceedings of the 20th European Frequency and Time Forum (EFTF)/European Navigation Conference (ENC), 27-30 March 2006, Geneva, Switzerland, pp. 455-459.
- [6] J. Plumb, 2003, “*Carrier phase time-transfer using global positioning system*,” Ph.D. thesis, University of Colorado.
- [7] A. de Latour., G. Cibiél, J. Dantepal, J.-F. Dutrey, M. Brunet, L. Ries, and J.-L. Issler, 2005, “*Dual-frequency absolute calibration of GPS receiver for time transfer*,” in Proceedings of the 19th European Frequency and Time Forum (EFTF), 21-24 March 2005, Besançon, France, pp. 360-365.

