

## **PTB'S TIME AND FREQUENCY ACTIVITIES IN 2008 AND 2009**

**M. Rost, A. Bauch, J. Becker, T. Feldmann, D. Piester, T. Polewka,  
D. Sibold, and E. Staliuniene**

**Physikalisch-Technische Bundesanstalt  
Bundesallee 100, 38116 Braunschweig, Germany**

**E-mail: *michael.rost@ptb.de***

**Tel: +49 531 592 4471, Fax: +49 531 592 4479**

### **Abstract**

*The Physikalisch-Technische Bundesanstalt (PTB) maintains the German national time scale, disseminates time and frequency for both business and general public, and undertakes research to improve its facilities. This report covers the activities of PTB's Time Dissemination Working Group during 2008 and 2009.*

*PTB's time scale UTC (PTB) is based on the primary clock CS2 and an associated phase micro-stepper to keep the time scale in reasonable agreement with UTC. CS2 and the other primary standards, CS1, CSF1, and CSF2, are part of PTB's ensemble of atomic clocks whose data are provided for the computation of TAI. During 2009, the commercial clocks have been moved step by step to a new clock room with improved operational conditions and state-of-the-art cabling.*

*A broad range of satellite time-transfer equipment is being operated to enable time scale comparisons with other institutes all over the world. Single/multi-channel GPS receivers as well as so-called geodetic receivers enable frequency and time transfer with the state-of-the-art evaluation techniques (C/A code, P3, carrier phase, PPP). Two-way satellite time and frequency transfer (TWSTFT) is made routinely with several stations in Europe, the US, and Asia. Several calibration campaigns have been performed, partly with substantial support of USNO and BIPM, which allowed verification of the time-transfer uncertainty using PTB's current equipment.*

*PTB provides services to disseminate time and frequency within Germany. The most prominent example is the low-frequency transmitter DCF77, which is widely used. In 2009, PTB looks back on 50 years operation of this service. Other time services are the NTP-servers as well as the telephone time service to synchronize computer via Internet or modem connection, respectively. The capability of the NTP infrastructure was enhanced by the introduction of an additional NTP server.*

*PTB acts as one of the four so-called UTC (k) laboratories cooperating with the future Galileo Time Service Provider. In this framework, its clock-monitoring and measurement systems have been refurbished and upgraded, looking forward to a long-term involvement in this activity. PTB has also supported the realization of one of Galileo's Precise Timing Facilities, and a status of this activity will be provided.*

## **INTRODUCTION**

The Physikalisch-Technische Bundesanstalt (PTB) maintains the German national time scale, disseminates time and frequency for both business and general public use, and undertakes research to improve its capabilities. PTB's time scale UTC (PTB) is based on the primary clock CS2 and an associated phase micro-stepper to keep the time scale in reasonable agreement with UTC. CS2 and the other primary frequency standards CS1 [1], CSF1 [2], and CSF2 [3] are part of PTB's group of atomic clocks whose data are provided for the computation of TAI.

A broad range of satellite time-transfer equipment is operated to enable time scale comparisons with other institutes all over the world. Single- and multi-channel GPS receivers, as well as so-called geodetic receivers, enable redundant frequency and time transfer with state-of-the-art evaluation techniques (C/A code, P3, carrier phase). Two-way satellite time and frequency transfer (TWSTFT) is routinely performed with several European and US stations.

PTB provides services to disseminate time and frequency within Germany, among which the low frequency transmitter DCF77 is the most prominent example. This service has been started 50 years ago in January 1959 with the beginning of transmission of time and frequency signals. Other time services are the NTP servers as well as the telephone time service to synchronize computer via Internet or modem connection, respectively. During 2008 and 2009 a new additional NTP server has been installed.

PTB contributes with its know-how and equipment to the design of the European Satellite Navigation System Galileo by building parts of the timing systems of a ground station and the so-called Time Service Provider.

In this paper, the time and frequency activities performed by PTB in the years 2008 and 2009 are presented.

## **TWSTT AND GPS ACTIVITIES**

PTB uses TWSTFT and GPS Time Transfer to compare the local time scale UTC (PTB) to various other time scales of laboratories spread all over the world, e.g. in Europe, USA, and Asia. The following paragraphs summarize the activities of PTB concerning these time transfer links. The results of most of these comparisons are used by the BIPM to compute TAI [4].

### **TWSTFT LINK CALIBRATIONS**

Since the last laboratory report presented at the PTTI Meeting in 2006 [5], PTB has participated regularly in TWSTFT calibration campaigns between the USNO and PTB and between European institutes. While, for the USNO-PTB link, the portable TWSTFT station from USNO was used, the links between the European stations have been calibrated by using the portable station of Joanneum Research/Technical University Graz (TUG, Austria). Here, we only focus on the PTB activities in Europe. Following the procedure as described in [6], the TWSTFT link between METAS (Bern-Wabern, Switzerland) and PTB was calibrated in 2006 [7]. One year later, the TUG portable station was transported to BEV (Vienna, Austria), establishing a temporary TWSTFT link to PTB. The parallel GPS link regularly used for the production of TAI could be calibrated with the smallest accepted uncertainty for a GPS link so far [8]. In 2008, the TWSTFT stations of seven European institutes were calibrated in an extensive campaign in the

framework of Fidelity project, delivering the Galileo Time Service Provider Prototype [9]. This campaign comprised the four so-called core UTC (k) laboratories INRIM (Torino, Italy), NPL (Teddington, UK), OP (Paris, France), and PTB, and, in addition, VSL (Delft, The Netherlands) and METAS [10]. In all these campaigns, the TWSTFT station of TUG was also calibrated. In Table 1, the estimated uncertainties of the reported TWSTFT link calibrations are summarized and the differential corrections to previous calibrations are stated. The results of the latest campaigns between ROA (San Fernando, Spain) and METAS and PTB using a portable GPS receiver (Nos. EG1 [11] and EG2 [12], respectively) have been added. The three calibrations of the link UTC (METAS) – UTC (PTB) illustrate the very good achieved reproducibility (see also subsection “GPS Link Calibration to METAS” below).

Table 1. Uncertainties achieved during recent TWSTFT calibration exercises between European laboratories and PTB. The results of the latest GPS-based link calibrations have been added (see Nos. EG1 and EG2). The listed absolute values of the differential corrections to previous calibrations are a measure of the reproducibility of repeated TWSTFT calibrations. For details, see the text.

Campaign No.	Year	Calibration technique	Link lab - PTB	Link technique	Uncertainty (ns)	Abs. differential correction (ns)
E5	2006	TWSTFT	METAS	TWSTFT	0.8	n/a
E6	2007	TWSTFT	BEV	GPS	1.93	n/a
EG1	2008	GPS	ROA	TWSTFT	1.7	< 1
E7	2008	TWSTFT	INRIM	TWSTFT	1.2	0.21
			METAS	TWSTFT	1.0	1.15
			NPL	TWSTFT	1.2	n/a
			OP	TWSTFT	1.1	0.47
			VSL	TWSTFT	2.1 <sup>1</sup>	16.73 <sup>1</sup>
EG2	2009	GPS	METAS	TWSTFT	1.4	1.17

<sup>1</sup>At VSL a significant larger statistical uncertainty was observed, accompanied with a significant large offset of the result, which might be attributed to data computation errors. These results were discarded and not implemented into the operational link

## TWSTFT SATELLITE CHANGE

Due to the limited lifetime of the Intelsat IS-707 satellite, which was used until January 2008 for Ku-band TWSTFT to Europe and USA, the community had to switch over to Intelsat IS-3R at the beginning of 2008. This satellite was operational until the mid of 2009, resulting in the need to switch over to another satellite. Since July 2009, the Ku-band TWSTFT link to other European and American laboratories has been made via Telstar T-11N.

The use of IS-3R satellite during 2008 and 2009 required modifications of transmitting hardware, as the transponders to Europe and the USA required signals at different polarization. Automatic switching components were implemented, adding the possibility to change polarization between measurements.

To save the calibration status, the gap in operations during satellite changes was bridged by using GPS PPP links and, in the case of the PTB-USNO link, by using the redundant TWSTFT X-band link. Consequences and results of the satellite changes have been discussed in [13].

## GPS LINK CALIBRATION TO METAS

During June and July 2009, the time links between METAS and PTB have been calibrated using a traveling GPS time and frequency transfer receiver (TR, type Dicom GTR50) [12]. First, the TR was operated at PTB and compared to a second fixed GTR50 receiver (PTB07) in a quasi zero-baseline common-clock experiment. The delay of the reference 1PPS signal for the TR with respect to UTC (PTB) was measured with a time-interval counter (TIC). Then, the TR was shipped to METAS and operated there connected to a 1PPS signal derived from the local UTC (CH). The 1PPS delay was also measured with a TIC of the same type. After the TR came back to PTB, a closure comparison with respect to PTB07 was performed, in order to verify that the TR internal delay during the calibration trip was unaffected.

While the TR was at PTB, a calibration value  $C_1$  was derived from the mean value of the common-clock difference (CCD) TR-PTB07. While the device was at METAS, it was compared to a stationary receiver located there (WAB2, Ashtech Z12-T) to get a second calibration value  $C_2$ . The calibration value for the GPS link UTC (PTB) – UTC (CH) with the stationary receivers can be computed from  $C_{\text{GPS}} = C_1 - C_2$ . Additionally, the temporary link between the PTB07 and the TR (at METAS) was compared to the operational TWSTFT link in parallel. Subtracting the difference GPS-TWSTFT including  $C_1$ , the calibration value for the TWSTFT link  $C_{\text{TW}}$  is given by the mean value of this difference. At first, the results of the calibration of the TW link using the GPS C/A code and then the results of the calibration of the PPP link between PTB07 and WAB2 are presented.

In Figure 1, the CCDs for C/A-code and PPP at PTB are depicted. A mean value -1.674 ns before the calibration trip and -1.579 ns thereafter is obtained for the C/A code, and -3.703 ns and -4.092 ns for the PPP method, respectively. The computation of calibration values results in  $C_{1,C/A} = -1.636$  ns and  $C_{1,PPP} = -3.898$  ns as the mean values of the two respective values before and after the trip.

In Figure 2, the corrected difference between the C/A code link and the previously calibrated TWSTFT link is shown while the TR was at METAS. The mean value directly corresponds to the calibration value for the TW link  $C_{\text{TW}} = -1.166$  ns. The visible instabilities for the PPP solutions in Figure 1 and the diurnal variations in Figure 2 may be due to lightning conductors mounted at some PTB antenna sites by the local authorities during the calibration period.

In Figure 3, the PPP CCD at METAS is depicted. The operation of the receivers is less noisy, but some of the data from MJD 55016-18 and 55021 are missing and a drift over the observed period is visible. Such drifts have also been observed in long-term comparisons between the PTB07 and the PTBB (Ashtech Z12-T), which are the same types of receivers as used for the data in Figure 3. The observed delay changes go up to 1 ns. The computation of the mean value results in  $C_{2,PPP} = -461.242$  ns and the calibration value for the PPP link is  $C_{\text{GPS,PPP}} = 457.344$  ns. For the uncertainties,  $U_{\text{TW}} = 1.4$  ns and  $U_{\text{GPS,PPP}} = 1.6$  ns were determined [12].

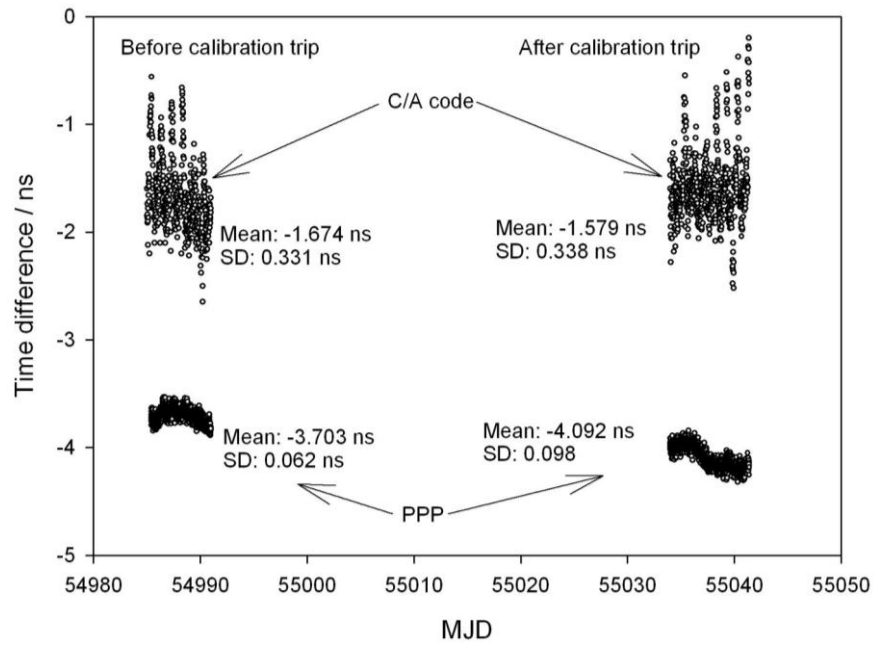

Figure 1. Common clock differences at PTB (TR-PTB07).

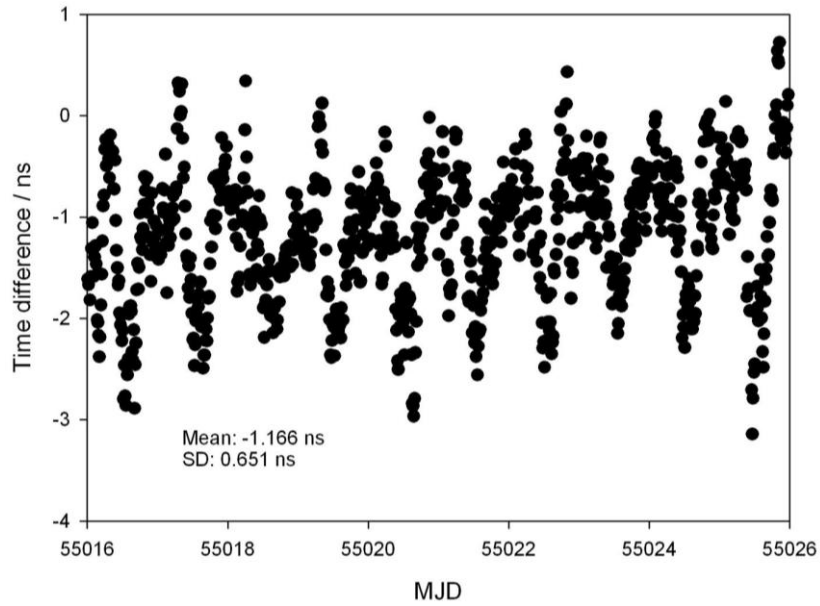

Figure 2. GPS C/A code – TWSTFT + 1.636 ns.

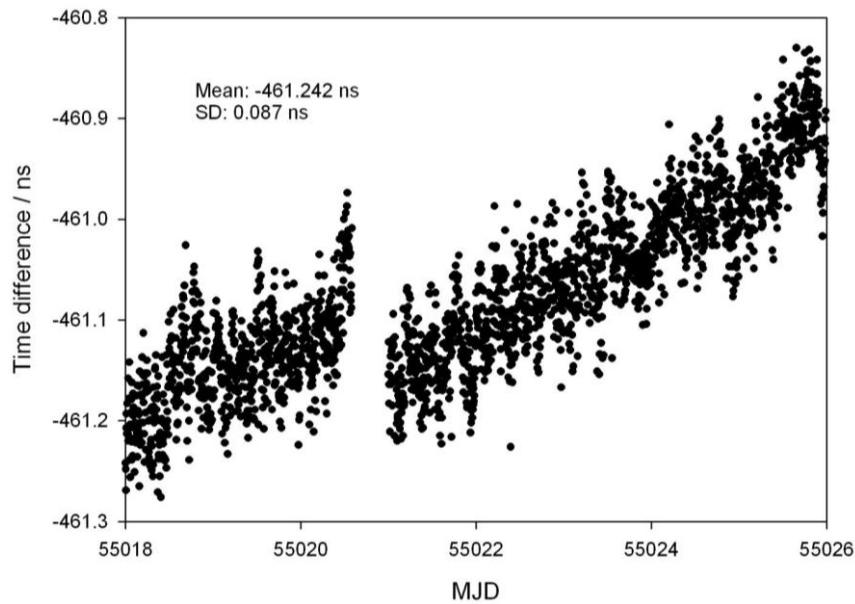

Figure 3. Common clock difference at METAS (TR-WAB2).

## DCF77 50<sup>TH</sup> ANNIVERSARY

DCF77 is the German time-transfer transmitter located near Frankfurt in the center of Germany providing German legal time and standard frequency over long wave at 77.5 kHz. Fifty years have passed since the service started its operation in 1959 by transmitting standard frequency and time measurement marks. It was originally used to support the telecommunications network of the Deutsche Bundespost (German Federal Postal Service, operating the German telecommunications network until beginning of the 1990s).

In 1973, a BCD scheme was added to the signal to transmit epoch information for the users, realized first by amplitude modulation. The code uses 60 bits per minute to transfer this information. Starting at second 21, the next full minute, followed by the hour, the day, the weekday, the month, and the last two digits of the year are transmitted (see Figure 4 for encoding scheme). Bits 1 to 14 are not used by PTB for the transmission of timing information, but are available for other services like disaster warnings and weather forecasts under the responsibility of the German Bundesamt für Bevölkerungsschutz und Katastrophenwarung (Federal Office of Civil Protection and Disaster Relief, BBK) and Meteo Time GmbH, respectively [14].

In Europe, there are estimated 100 Million receivers using DCF77. The signal covers all parts of Middle Europe, ranging approximately 1500-2000 km (see Figure 4). Not only private receivers, but thousands of official clocks in Germany use the service.

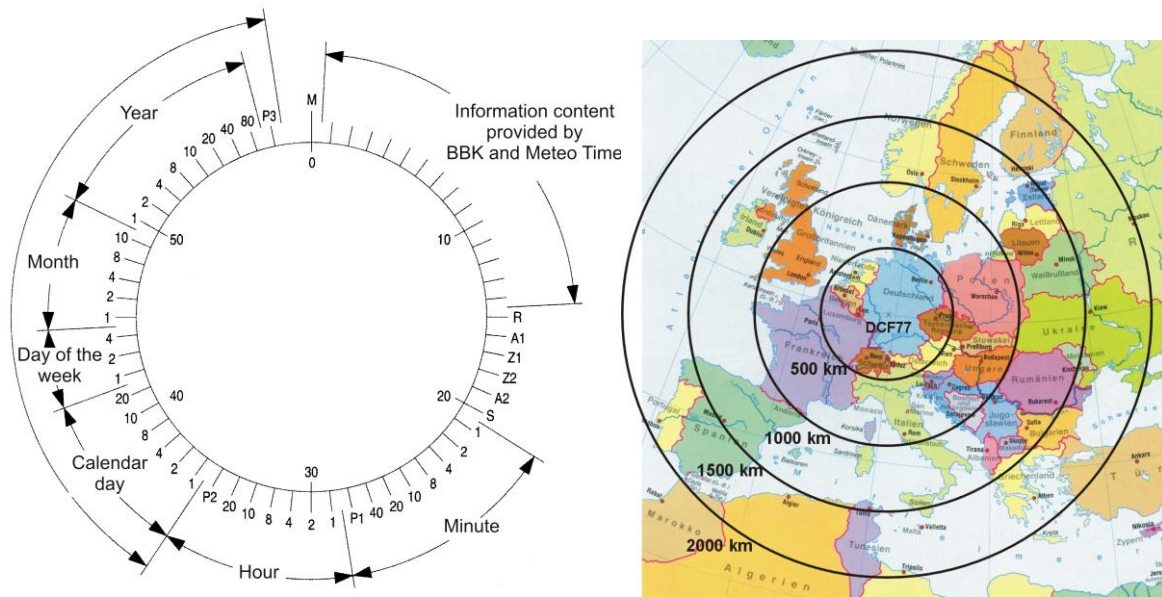

Figure 4. Left: DCF77 encoding scheme; for detailed description, refer to [15]. Right: Coverage of DCF77 signal in Europe; very schematic.

## NEW CLOCK ROOM

In August 2009, PTB started to use a new clock room by moving the hydrogen masers out of the clock hall, the place where traditionally PTB's operational atomic clocks have been located. The new room combines high temperature stability with the prevention of frequent personnel trespassing (as it has been unavoidably the case at the old maser location at PTB's clock hall). It provides space for at least four hydrogen masers (which are not isolated from each other) and a rack holding PTB's 5071A cesium clocks. In Figure 5, the actual ensemble of commercial atomic clocks of PTB is shown inside the new clock room.



Figure 5. PTB's new clock room hosting four masers and 5071A cesium clocks.

Before starting to use the new room, the environmental conditions inside have been carefully monitored over some weeks. The following Figure 6 shows the temperature at rack position (right side in Figure 5) over 3 days in September 2009; the temperature variations have been less than 0.1 K. The time constant of the probe is about 5 minutes.

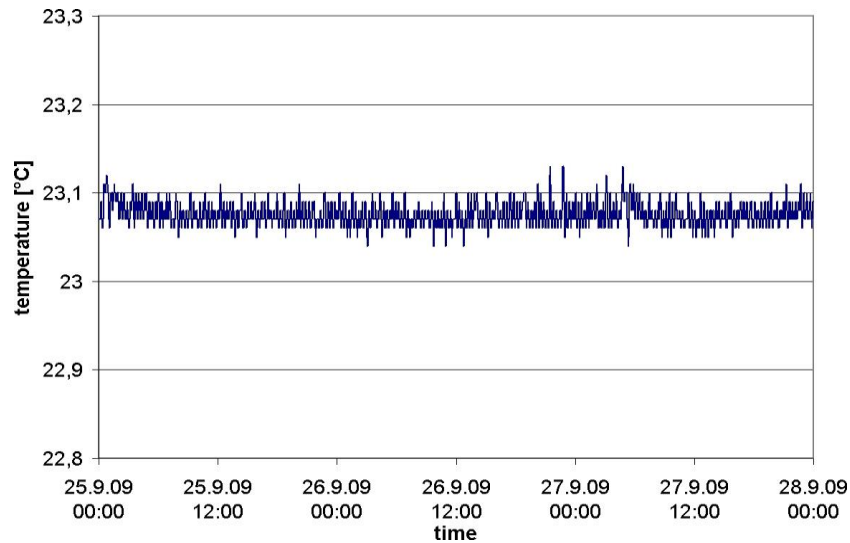

Figure 6. Temperature inside the maser room during 3 days in September 2009.

## NTP SERVER STATUS

### INTRODUCTION OF PTBTIME3.PTB.DE

During the last 2 years, the NTP request rate increased from 700 to 2100 requests per second; the number of requests received over the “time”-protocol rose as well, resulting in a high load on the time servers. To avoid bad NTP performance, the maximum request rate for the “time”-protocol was limited to 50 and 25 requests per second for the time servers *ptbtime1.ptb.de* and *ptbtime2.ptb.de*, respectively.

In order to comply with the increasing demands a third NTP server named *ptbtime3.ptb.de* was introduced. In contrast to *ptbtime1(2).ptb.de*, this NTP-server does not use a permanent 1PPS connection as the primary time signal; instead, it reads time from PCI-based time code generators which are synchronized to UTC (PTB) by means of IRIG-B protocol and initialized once by a 1PPS connection with UTC (PTB). This IRIG generation is permanently monitored against UTC (PTB).

This configuration allows the use of standard and powerful server hardware with a standard operating system for the setup of the time servers. The NTP performance obtained with regard to stability is not as good as obtained with a 1PPS signal, as displayed in Figure 7 in which the TDEV of *ptbtime1.ptb.de* and *ptbtime3.ptb.de* are compared. Figure 7 shows that the TDEV of *ptbtime3.ptb.de* always is smaller than  $2 \times 10^{-5}$  seconds, hence sufficient for the purpose of Internet time service [5].



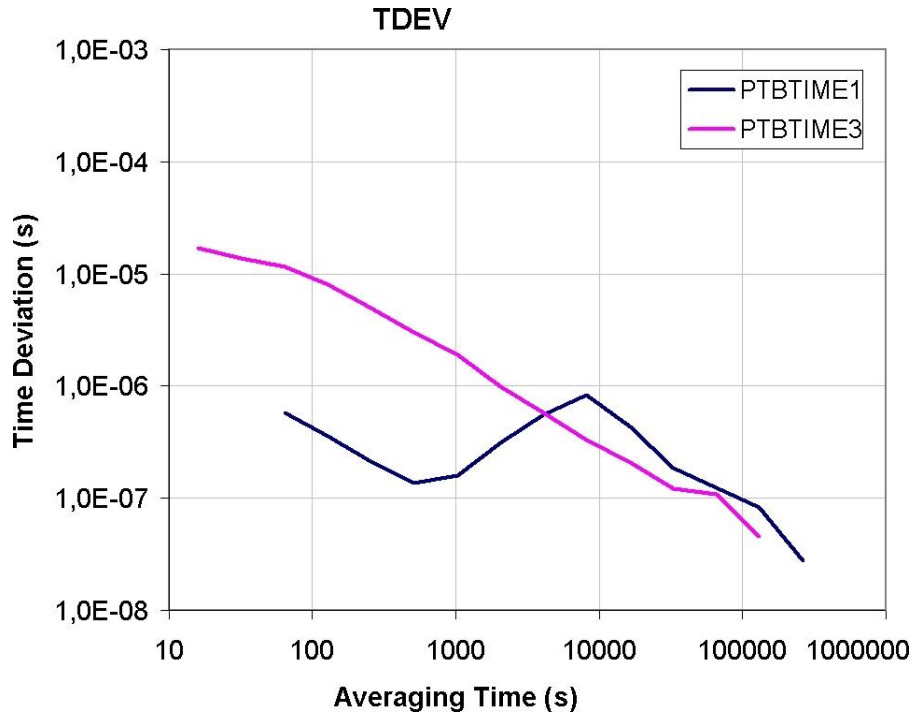

Figure 7. TDEV for PTB’s NTP servers *ptbtime1* and *ptbtime3*. Due to the synchronization of the new NTP server *ptbtime3* via IRIG-B, its stability at short time scales is worse than those of *ptbtime1*, which is directly connected to UTC (PTB) via 1PPS signal.

### NTP TIME SERVICE FOR A FEDERAL GOVERNMENT NETWORK

Due to IT security regulations, German government agencies which obtain data network services from the closed German Government Network IVBV are not allowed to use PTB’s open accessible time servers. In order to provide an IT security-compliant time service for these agencies, PTB’s NTP time service infrastructure was supplemented by two virtualized NTP time servers which are connected via an IPsec tunnel to the IVBV. Consequently, the IVBV and dependent Government agencies are now able to receive time synchronization under secure conditions from PTB at Stratum-level 2.

### DENIAL-OF-SERVICE ATTACK DECEMBER 2008

Due to misbehavior of the time keeping software “chrony,” which is frequently used in Linux/Debian systems, a denial-of-service attack against our NTP servers *ptbtime1(2).ptb.de* was generated in 2008, which resulted temporarily in a partially breakdown of PTB’s NTP time service. To be now prepared for such accidental or malicious clogging attacks, we configured the NTP processes of our time service in such a way that only NTP requests which comply to best practices will be answered by the servers [16]. This policy was activated 18 November 2008. The effect can be immediately observed in Figure 8.

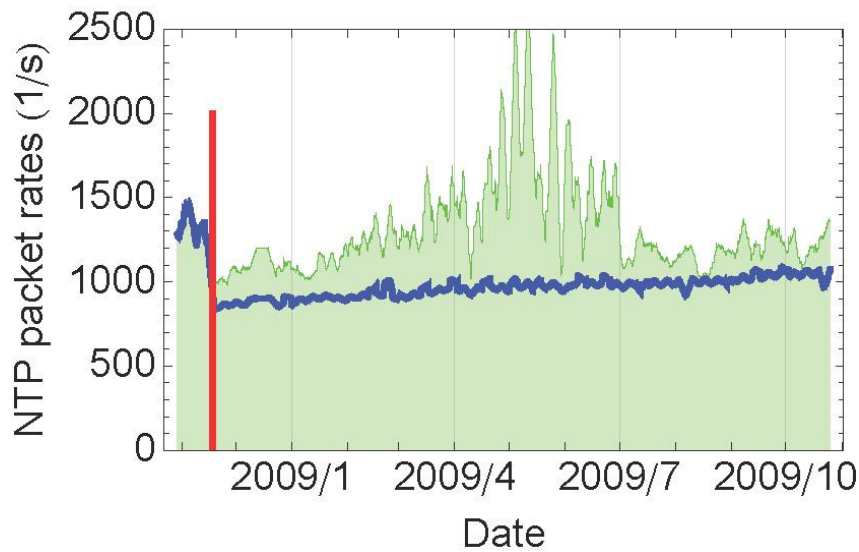

Figure 8. NTP traffic load: Until November 2008 all NTP requests have been answered (blue graph). After the reconfiguration on 18 Nov 2008 (red line), only requests complying with best practices have been answered, resulting in an unanswered overhead of requests (green area above blue graph).

## GALILEO

PTB's contribution to the IOV-phase infrastructure of the European Satellite Navigation System GALILEO during the last 2 years consists of three parts for the timing facilities of the Galileo Ground Segment. Two of these are subsystems designed and assembled by PTB and will be located in one of the two Precise Timing Facilities (PTF) of Galileo, maintaining the Galileo System Time (GST). The third contribution of PTB is the participation on the development of the time comparison and steering system of Galileo (Galileo Time Service Provider, GTSP [9]). The following sections are focused on the PTF systems and do not go into detail with the GTSP activities.

### GALILEO PTF

The two PTFs will be located at the Galileo Control Centers (GCC). Figure 9 shows a basic configuration of the Galileo timing system. The main part of the PTF are: the Master Clock Ensemble (MCE), consisting of two active hydrogen masers (AHM), that acts as the main reference for GST, which is generated by the GST Realization Subsystem (GRS). The GRS achieves correction commands from the Galileo Time Service Provider (GTSP), which is an external facility processing TWSTFT and GPS/Galileo time comparison data and delivering steering corrections to the Galileo core system. The time transfer is performed between the PTF (using the Time and Frequency Transfer Subsystem (TFSS)) and the participating core time laboratories (INRiM, NPL, OP, and PTB for prototype implementation of TSP). The PTF internal data are recorded and provided by the local measurement system (LMS). If the link to the GTSP is broken or no valid correction signal is received, the Reference Clock Ensemble (RCE) ensures long-term stability of the PTF in autonomous operation mode.

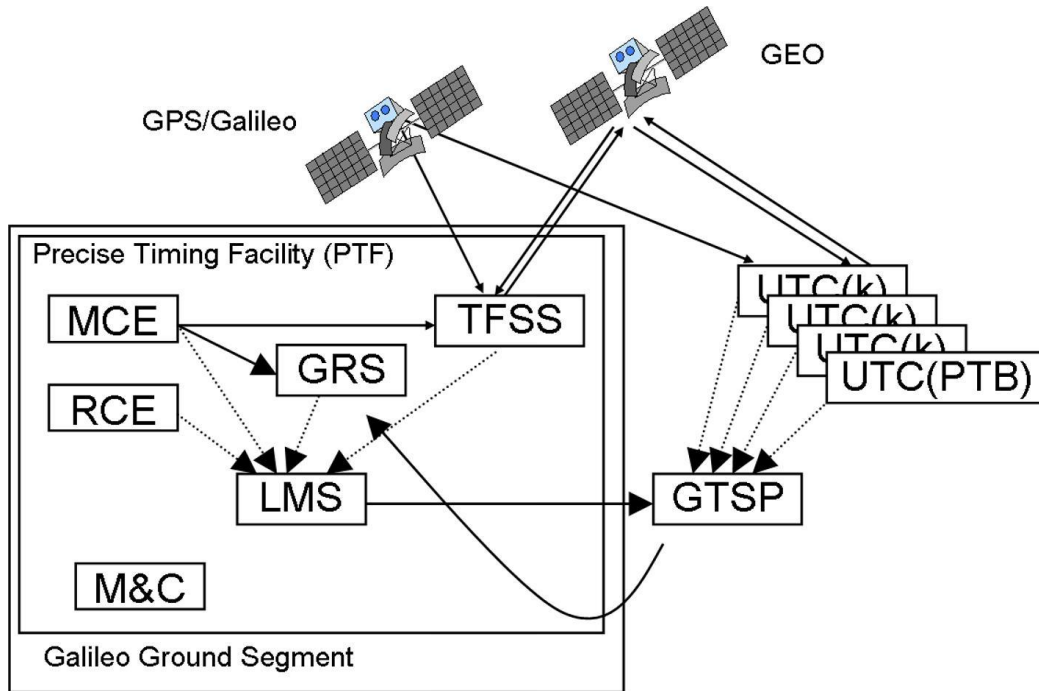

Figure 9. Galileo Precise Timing Facility (PTF); schematic view.

The following section focuses on the RCE and the GRS for the PTF located in Oberpfaffenhofen near Munich (PTFK).

### REFERENCE CLOCK ENSEMBLE - RCE

The Reference Clock Ensemble (RCE) is the part of the Galileo PTF, which ensures the long-term stability of GST during periods when the GTSP is not available. For these purposes, the RCE is equipped with four Symmetricom 5071A cesium Clocks (see Figure 10).

The cesium clocks are connected to uninterruptible power supply units, each in a doubly redundant way. Each uninterruptible power supply serves one cesium clock via AC and a different one via DC, protecting the clocks from powering down on failure of a single power supply. The stability of the cesium clocks has been checked against specification using the PTB primary clock CS2 as a common reference (see Figure 11).

### GST REALIZATION SUBSYSTEM – GRS

One of the active hydrogen masers (AHM) is selected as the PTF master clock by the GRS. Galileo System Time is generated from the master AHM signal and the slave AHM is tracked to the master AHM by using a phase micro-stepper (PMS). The master PMS is steered via the Monitoring and Control Subsystem (M&C) by applying steering commands received from the Galileo Time Service Provider.



Figure 10. Reference Clock Ensemble (RCE) and GST Realization Subsystem (GRS): The left cabinet contains the uninterruptible power supply, while the Symmetricom 5071A cesium clocks are located in the center cabinet. The cabinet on the right side contains the components of the GRS (see text below for further details on GRS).

The steered signal from the master AHM is distributed inside the Galileo Ground Segment by various techniques: 10 Mhz and 1PPS signals are available for direct use as well as computer NTP servers and analog IRIG-B time signals. All these signals are generated and distributed by the GRS. The power supply of the GRS is supported by uninterruptible power supplies, which serve both branches of the signal generation and distribution – master and slave – in a redundant way.

The complete RCE system has been designed and built at PTB. All the devices have been checked against specification at PTB. The following sample in Figure 12 shows the frequency instability contribution of both PMS, comparing the input and output frequency using a high-resolution phase comparator.

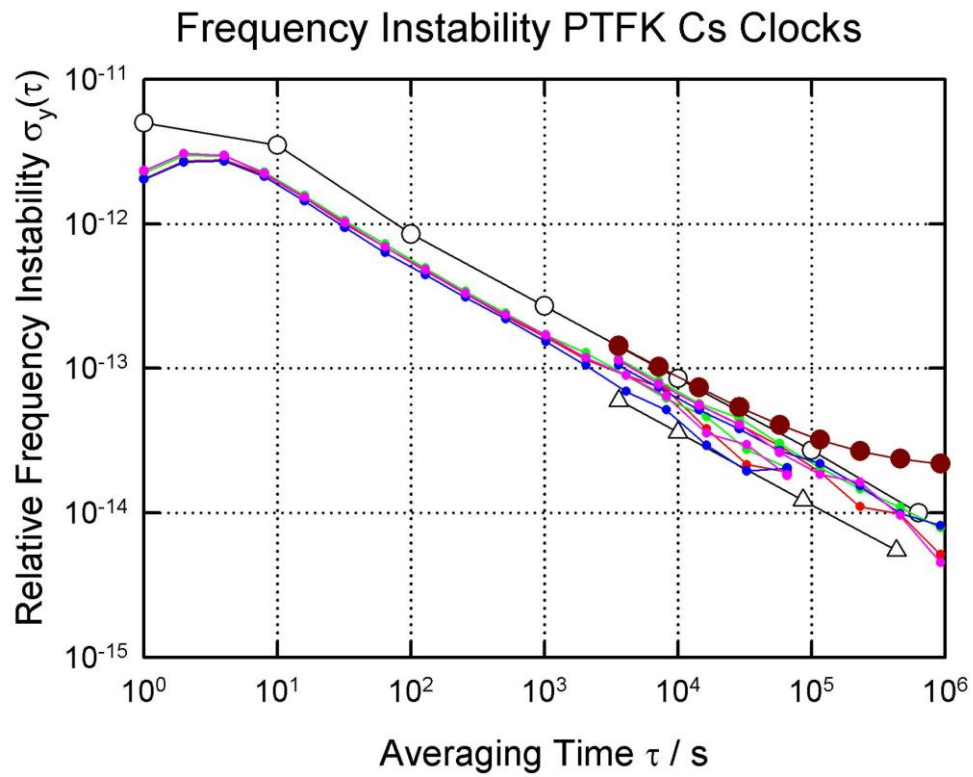

Figure 11. Instability of RCE cesium clocks. Large white circles: specification of 5071A clock type; large dark red circles: requirement for RCE system; white triangles: PTB's primary frequency standard CS2 (used as reference); small red, magenta, blue, and green circles: four RCE cesium clocks under test. The 5071A cesium clocks meet the manufacturer specifications; the  $\sigma_y(\tau)$  values lie between the primary clock CS2 and the RCE requirement.

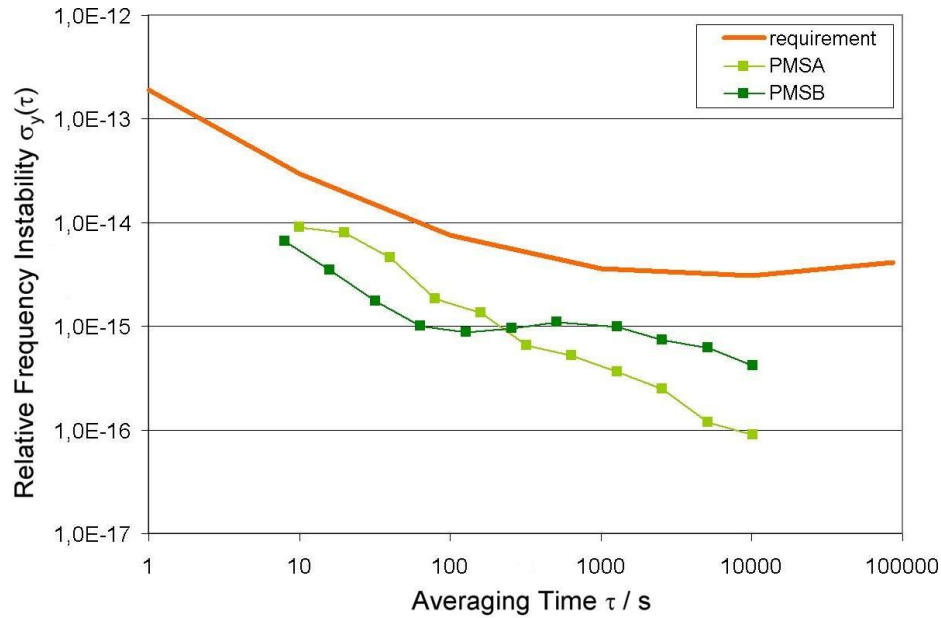

Figure 12. Instability of the two phase micro-steppers of the GRS: The orange line represents the GST instability requirement; the green lines represent the instability contribution of the phase micro-steppers. It does not exceed the required stability and does not degrade the maser's signal performance.

## OUTLOOK AND CONCLUSION

In the near future there are some upcoming tasks:

Transfer of Galileo equipment. It is expected that the GCC location will be finished in the first half of 2010. Then, the Galileo components developed and built by PTB will be transferred to Oberpfaffenhofen.

PTB plans to move their TWSTFT equipment to a common location. Until now, the TWSTFT stations for the European, Asian, and USA links have been spread over the PTB campus, due to the need of free sight to the satellite positions. From 2010 onwards, PTB will concentrate the stations on the top of a high building, where free sight to all directions is available (see Figure 13 for details). It is also planned to set up ACES hardware at this location, when it becomes available. Especially for this project, it is necessary to establish a time scale in well known relation to UTC (PTB) for calibration and monitoring issues in a new laboratory next to the time transfer equipment. For this purpose, PTB is working on concepts for Time Transfer through Optical Fibers (TTTOF) that shall connect the new TWSTFT location to PTB's time laboratory. This topic is dealt in detail with in [17].

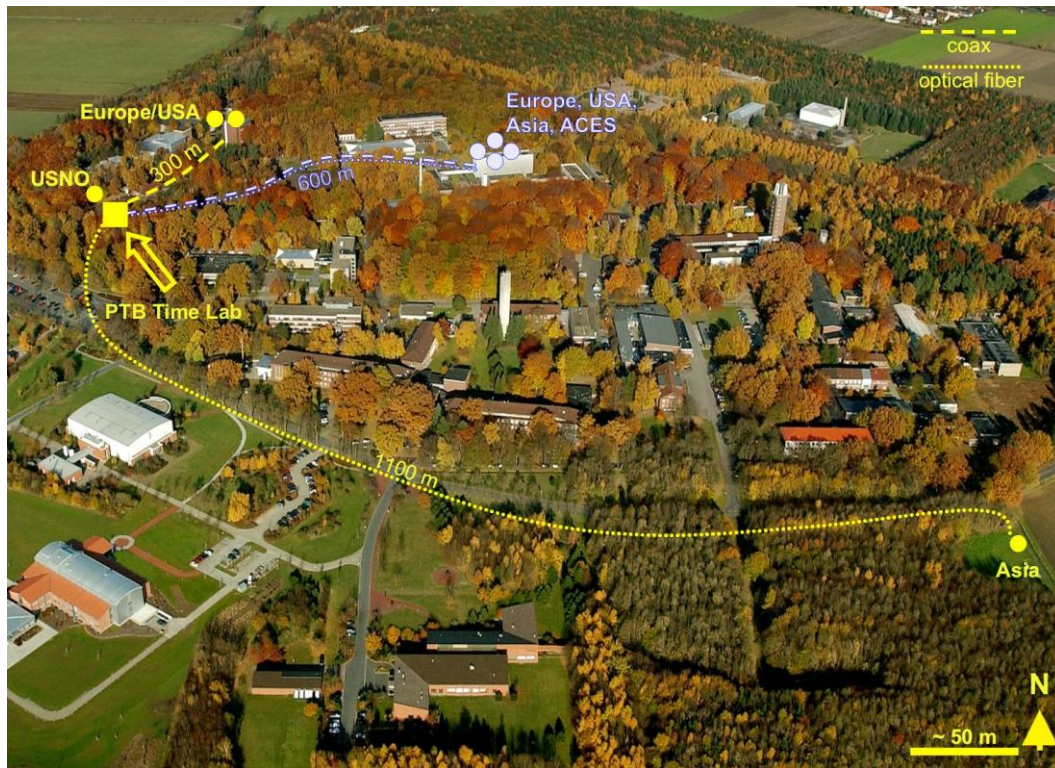

Figure 13. Facilities and signal connections for the TWSTFT links to Europe, USA, and Asia (yellow) and planned transfer of the equipment to another building (light blue).

## ACKNOWLEDGMENT

The results presented in this report are part of the fruitful collaboration between PTB and the following time laboratories: BEV, INRiM, METAS, NICT, NPL, OP, ROA, TUG, USNO, and VSL. The authors appreciate the support of METAS during the GPS calibration campaign, especially Christian Schlunegger, Laurent-Guy Bernier, and André Stefanov. We take the opportunity in this laboratory report to provide the latest results to a broader interested community.

GALILEO is a program sponsored by the European Space Agency and the European Union.

## DISCLAIMER

The Physikalisch-Technische Bundesanstalt as a matter of policy does not endorse any commercial product. The mentioning of brands and individual models seems justified here, because all information provided is based on publicly available material or data taken at PTB and it will help the reader to make comparisons with own observations.

## REFERENCES

- [1] A. Bauch, 2005, “*The PTB primary clocks CS1 and CS2*,” **Metrologia**, **42**, S43-S54.
- [2] R. Wynands and S. Weyers, 2005, “*Atomic fountain clocks*,” **Metrologia**, **42**, S64-S79.
- [3] V. Gerginov, N. Nemitz, S. Weyers, R. Schröder, D. Griebisch, and R. Wynands, 2010, “*Uncertainty evaluation of the caesium fountain clock PTB-CSF2*,” **Metrologia**, **47**, 65-79.
- [4] W. Lewandowski, G. Panfilo, A. Harmegnies, and F. Arias, 2010, “*BIPM time section update*,” in Proceedings of the 41st Annual Precise Time and Time Interval (PTTI) Systems and Applications Meeting, 16-19 November 2009, Santa Ana Pueblo, New Mexico, USA (U.S. Naval Observatory, Washington, D.C.), pp. 183-188.
- [5] D. Piester, A. Bauch, J. Becker, T. Polewka, M. Rost, D. Sibold, and E. Staliuniene, 2006, “*PTB’s Time and Frequency Activities in 2006: New DCF77 Electronics, New NTP Servers, and Calibration Activities*,” in Proceedings of the 38th Annual Precise Time and Time Interval (PTTI) Systems and Applications Meeting, 5-7 December 2006, Reston, Virginia, USA (U.S. Naval Observatory, Washington, D.C.), pp. 37-47.
- [6] D. Piester, A. Bauch, L. Breakiron, D. Matsakis, B. Blanzano, and O. Koudelka, 2008, “*Time transfer with nanosecond accuracy for the realization of International Atomic Time*,” **Metrologia**, **45**, 185-198.
- [7] C. Schlunegger, G. Dudle, L.-G. Bernier, D. Piester, J. Becker, and B. Blanzano, 2007, “*Description of the TWSTFT Station at METAS and Presentation of the Calibration Campaign 2006*,” in Proceedings of the IEEE International Frequency Control Symposium (FCS) Jointly with the 21st European Frequency and Time Forum (EFTF), 29 May-1 Jun 2007, Geneva, Switzerland (IEEE 07CH37839), pp. 918-922.
- [8] A. Niessner, W. Mache, B. Blanzano, O. Koudelka, J. Becker, D. Piester, Z. Jiang, and F. Arias, 2009, “*Calibration of the BEV GPS receiver by using TWSTFT*,” in Proceedings of the 40th Annual Precise Time and Time Interval (PTTI) Systems and Applications Meeting, 1-4 December 2008, Reston, Virginia, USA (U.S. Naval Observatory, Washington, D.C.), pp. 543-548.
- [9] J. Achkar, P. Tuckey, P. Urich, D. Valat, A. Batchelor, G. Burden, A. Bauch, D. Piester, F. Cordara, P. Tavella, J. Davis, J. Delparte, R. Jones, T. Levin, G. Staton, J. Nawrocki, and J.-M. Piéplu, 2007, “*Fidelity – Progress Report on Delivering the Prototype Galileo Time Service Provider*,” in Proceedings of the IEEE International Frequency Control Symposium (FCS) Jointly with the 21st European Frequency and Time Forum (EFTF), 29 May-1 Jun 2007, Geneva, Switzerland (IEEE 07CH37839), pp. 446-451.
- [10] A. Bauch, D. Piester, B. Blanzano, O. Koudelka, E. Kroon, E. Dierikx, P. Whibberley, J. Achkar, D. Rovera, L. Lorini, F. Cordara, and C. Schlunegger, 2009, “*Results of the 2008 TWSTFT Calibration of Seven European Stations*,” in Proceedings of the European Frequency and Time Forum (EFTF) Jointly with the IEEE Frequency Control Symposium (FCS), 20-24 April 2009, Besançon, France, pp. 1209-1215.



- [11] H. Esteban, J. Palacio, F. J. Galindo, T. Feldmann, A. Bauch, and D. Piester, 2010, “*Improved GPS-based time link calibration involving ROA and PTB,*” **IEEE Transactions on Ultrasonics, Ferroelectric, and Frequency Control**, in press.
- [12] T. Feldmann, A. Bauch, and D. Piester, 2009, “*Study on the GPS Calibration Accuracy and Code Free Carrier-Phase GPS Time and Frequency Transfer,*” in Proceedings of the 2nd International Colloquium Scientific and Fundamental Aspects of the Galileo Programme, 14-16 October 2009, Padua, Italy.
- [13] V. Zhang, T. E. Parker, J. Achkar, A. Bauch, L. Lorini, D. Matsakis, D. Piester, and D. Rovera, 2010, “*Two-way time and frequency transfer using 1 MChip/s codes,*” in Proceedings of the 41st Annual Precise Time and Time Interval (PTTI) Systems and Applications Meeting, 16-19 November 2009, Santa Ana Pueblo, New Mexico, USA (U.S. Naval Observatory, Washington, D.C.), pp. 371-382.
- [14] [www.meteotime.ch](http://www.meteotime.ch)
- [15] F. Riehle, 2004, **Frequency Standards; Basics and Applications** (Wiley-VCH, Weinheim).
- [16] D. L. Mills, 2006, **Computer Network Time Synchronization** (CRC Press, Taylor & Francis Group, LLC).
- [17] D. Piester, M. Fujieda, M. Rost, and A. Bauch, 2010, “*Time Transfer Through Optical Fibers: First Results for Calibrated Clock Comparisons,*” in Proceedings of the 41st Annual Precise Time and Time Interval (PTTI) Systems and Applications Meeting, 16-19 November 2009, Santa Ana Pueblo, New Mexico, USA (U.S. Naval Observatory, Washington, D.C.), pp. 89-100.

