

# ULTRASTABLE OSCILLATORS FOR SPACE APPLICATIONS

**Peter Cash, Don Emmons, and Johan Welgemoed  
Symmetricom, Inc.**

## Abstract

*The requirements for high-stability ovenized quartz oscillators have been increasing in space applications. These devices provide attractive size, weight, power, and reliability for use in space missions; they also exhibit short-term frequency stability that rivals that of the best atomic-based signal sources.*

*Symmetricom has delivered flight oscillators for the Lunar Reconnaissance Orbiter and other military programs that have demonstrated  $1 \times 10^{-13}$  Allan deviation for time intervals of 10 to 100 seconds and sub  $2 \times 10^{-13}$  stability to 10,000 seconds. The oscillator, the model 9500, which was developed in 1995, has undergone improvements, including the use of higher stability glass-encapsulated quartz resonators to increase performance for current scientific and military applications. Our presentation will describe the oscillator, the measured performance of various units, and data from the Lunar Reconnaissance Orbiter.*

## INTRODUCTION

Quartz oscillators have been a critical part of the timing and frequency generation architecture of satellites since the beginning of the space program. The levels of performance of the crystal oscillators are highly dependent on the application and mission environments. In critical applications for timing or spectral purity, Ultrastable Oscillators are necessary to achieve system performance requirements. Symmetricom defines such an oscillator as capable of producing frequency stability on the order of  $2 \times 10^{-13}$  or less for time periods of 1-100 seconds. Inherent in this type of performance are equivalent phase noise, temperature stability, minimal incidence of frequency jumps and long-term frequency accuracy. This paper will describe the parameters that define an Ultrastable Oscillator, discuss the critical aspects of the design and analyses, and describe a recent application on the Lunar Reconnaissance Orbiter.

## KEY CHARACTERISTICS AND DATA

Phase noise and Allan deviation are the best performance parameters to delineate an Ultrastable Oscillator from more modest ovenized oscillators. Ultrastable Oscillators typically have frequency stabilities on the order of  $1 \times 10^{-13}$  for time intervals of 1 to 100 seconds and maintain similar stability to time durations of 1000 to 10,000 seconds. This level of performance is indicative of excellent phase noise close to the carrier on the order of -127 dBc/Hz at a 1-Hz offset frequency. Ultrastable Oscillators optimized for this

level of performance rely on lower crystal drive currents and a trade-off the phase noise floor. The table below shows representative measured frequency stability of the Symmetricom model 9500 oscillator measured against a second Ultrastable Oscillator.

	Typical Performance
<b>T=1 second</b>	<b><math>1.1 \times 10^{-13}</math></b>
<b>T=10 seconds</b>	<b><math>1.3 \times 10^{-13}</math></b>
<b>T=100 seconds</b>	<b><math>1.5 \times 10^{-13}</math></b>

Longer-term stability measured against an active hydrogen maser is shown on the following page. This oscillator, which was delivered to the Goddard Space Flight Center for the Moon Reconnaissance Orbiter, shows exceptional long-term stability for a quartz frequency source. Symmetricom has show similar performance on other space programs.

The capability to achieve these stabilities is a product of a low-noise crystal and oscillator electronics for the 1- to 10-second time interval and by thermal stability for long time periods. The intrinsic temperature of stability of Ultrastable Oscillators is typically  $1\text{-}3 \times 10^{-12}$  per °C. A measurement of a production oscillator appears in Figure 2. These data were taken in thermal vacuum with a temperature change of -20°C to 50°C.

Frequency jumps are also an important consideration in Ultrastable Oscillators. All crystal oscillators exhibit frequency jumps of varying magnitudes. The jumps are a result of stress relaxation of the crystal resonator over time and are a function of the quality of the crystal design and manufacturing processes. Critical to the crystal manufacturing process are blank preparation and surface finish, uniformity of the plating process, and contamination within the crystal envelope. The magnitude of the frequency jumps in Ultrastable Oscillators is expected to be less than  $2 \times 10^{-12}$  and occur infrequently. In addition to selecting a crystal supplier capable of such design and processing, crystals must be screened for frequency jumps in an oscillator.

The final key characteristic of Ultrastable Oscillators is frequency accuracy. The frequency accuracy of oscillators is a product of multiple factors, including aging, radiation exposure, shock and vibration, and environmental sensitivities. The largest factor is the drift rate of the crystal. Precision crystals have demonstrated aging performance of less than  $3 \times 10^{-11}$  per day prior to shipment, with ultimate drift rates of less than  $1 \times 10^{-11}$ . These result in accuracy on the order of  $1 \times 10^{-7}$  for a typical 10- to 15-year mission. Radiation effects are typically a second-order effect, with a total sensitivity of less than  $1 \times 10^{-8}$ .

## CRYSTAL SELECTION

The quartz crystal is the most important component in an oscillator. Symmetricom has used Bliley Technologies crystals for the majority of its Ultrastable Oscillators. Recently, the use of the BG61 crystal has shown further improvements in frequency stability. The crystals used have been 5.0 MHz and 5.115 MHz 3<sup>rd</sup>-overtone SC-cut crystals. The BG61 crystal has several unique design and manufacturing properties that have advanced the state-of-the-art performance in quartz oscillators. The first unique aspect of the crystal is the use of brazed attachment of the quartz blank to the mounting structure. The removal of epoxy from the manufacturing processing eliminates a potential contaminant and allows for

higher-temperature bake out of the crystal prior to sealing. The second aspect is the use of an intermediate platform of ceramic that increases the thermal and mechanical isolation throughout the enclosure. The Biley crystals have shown stabilities as low as  $7 \times 10^{-14}$  in oscillators manufactured at Symmetricom and The Johns Hopkins University Applied Physics Laboratory.

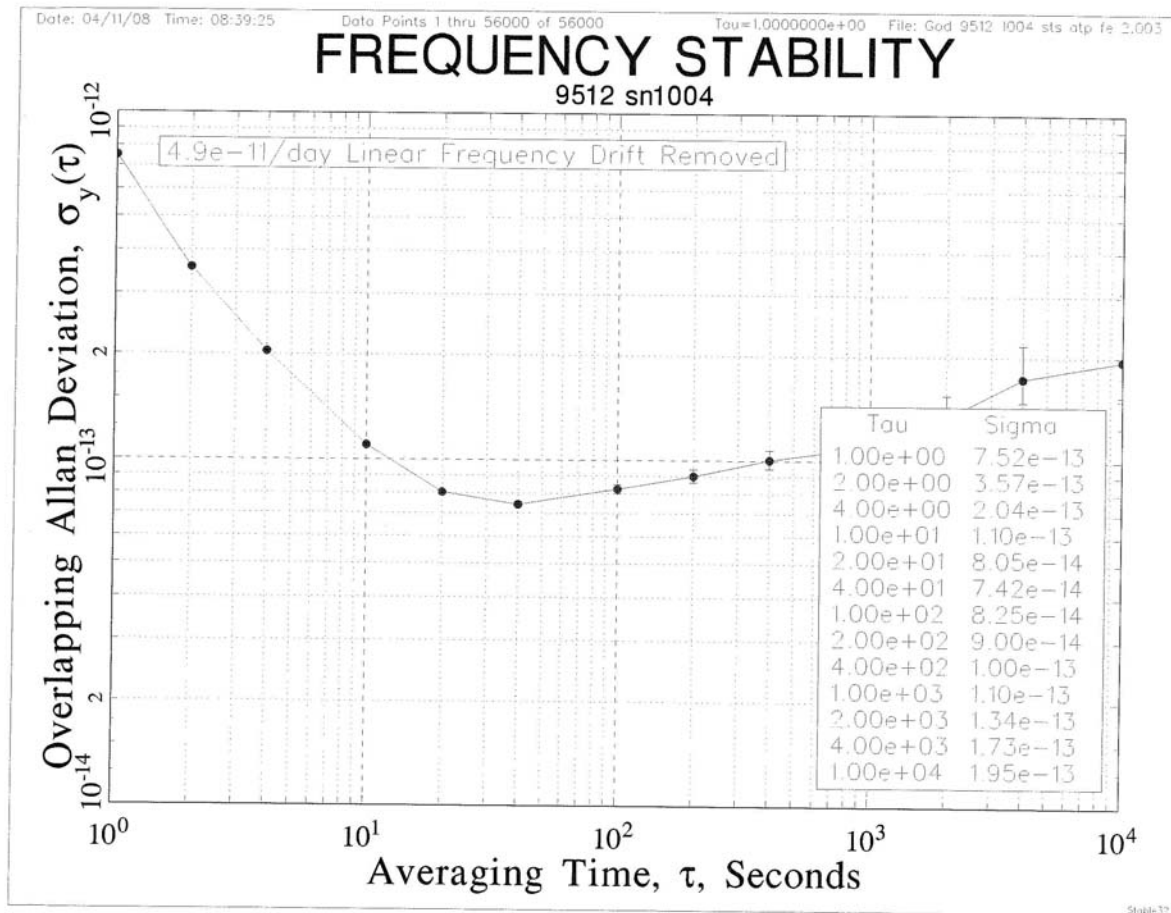

Figure 1. Long-term frequency stability of the Symmetricom 9512 Ultrastable Oscillator.

## OSCILLATOR DESIGN CONSIDERATIONS

Symmetricom's ovenized oscillator designs are based upon a heritage modified Colpitts configuration. In the case of Ultrastable Oscillators, the performance is maximized by special selection of low-noise active components and optimization of the performance in vacuum by careful selection of the operating temperature of the crystal. A key element in the oscillator design is a high-gain proportional controlled oven. The model 9500 exhibits a thermal gain in excess of 1000 with a carefully designed spherically isothermal construction. All components which exhibit temperature sensitivities that impact the output frequency are maintained within the oven assembly. These circuits include the oscillator sustaining section, the oven control and voltage regulator, and the optional digital frequency control functions. The block diagram below represents a cross section of the standard design.

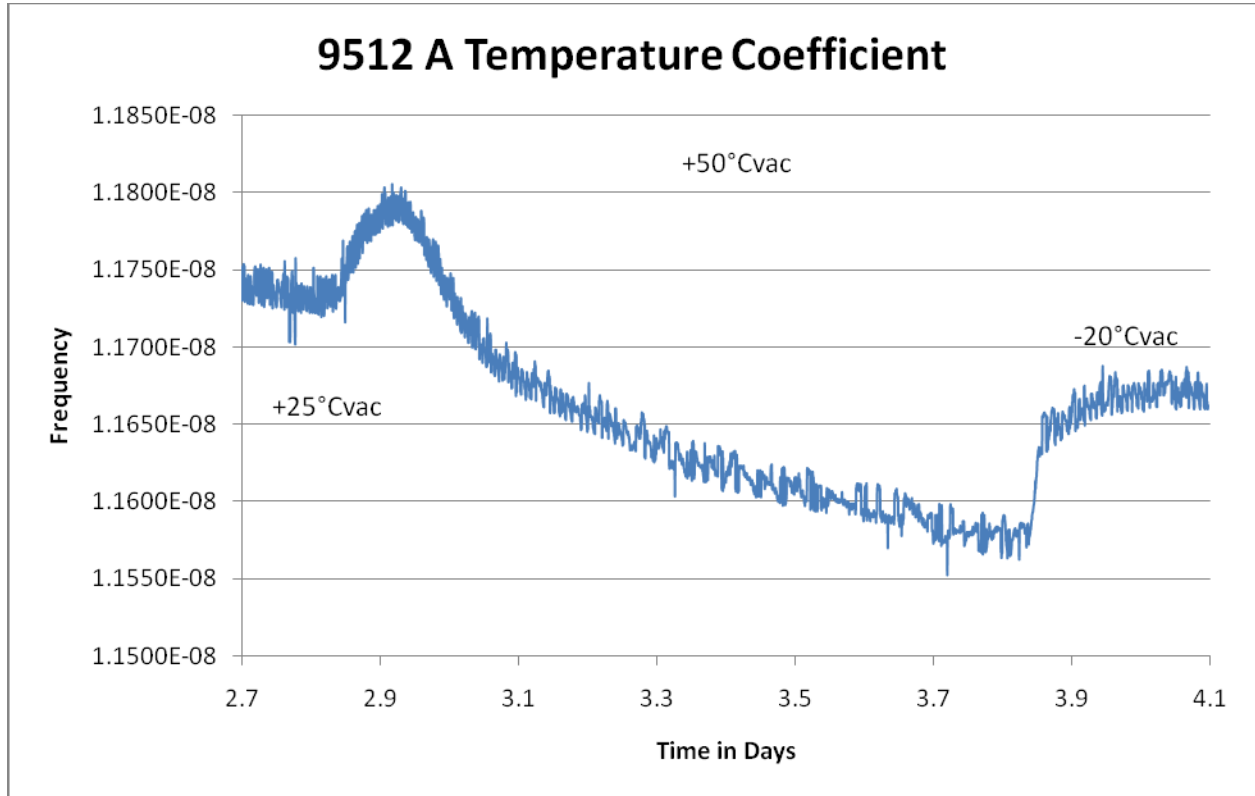

Figure 2. Model 9512 measured temperature stability.

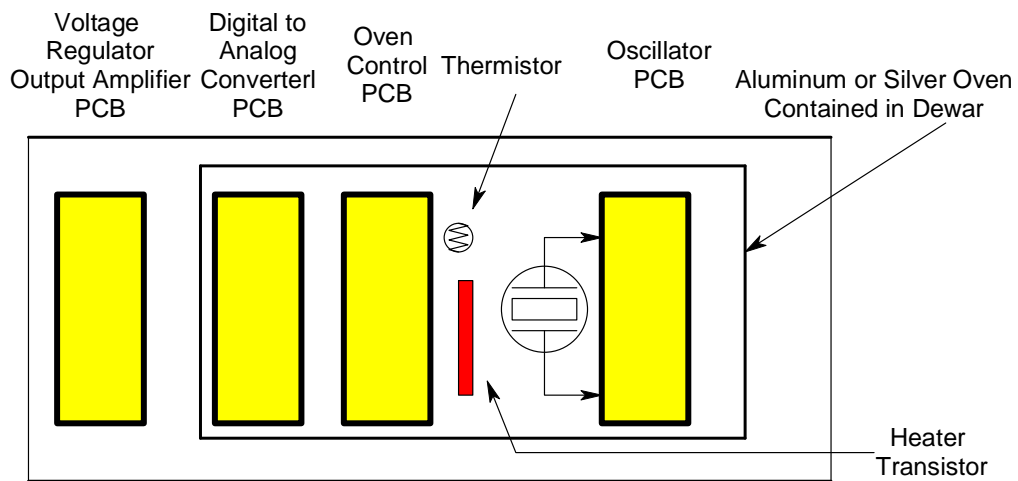

Figure 3. Model 9500 cross section.

## ENVIRONMENTAL CONSIDERATIONS

The space environment represents design challenges to enable the successful launch of an oscillator and continued performance. Although the mechanical durability is less critical in operation, the vibration and pyrotechnic shock exposure during the satellite liftoff is capable of damaging or compromising the performance of the oscillator. Typical vibration levels exceed 20 grms with pyroshock inputs exceeding 3000g's. Mitigation of the risk to the oscillator is accomplished by the utilization of a shock and vibration isolation system. The system can be external to the oscillator or in cases where envelop is critical the isolation is accomplished internally. Symmetricom's isolation systems have a mechanical resonance frequency of approximately 100 Hz, which attenuates the vibration and shock input to a level of 10 times less at the critical 2-3 kHz resonant frequencies of the quartz crystals.

The radiation environment, both natural and manmade, is an important consideration in Ultrastable Oscillator design. Traditional total dose exposures are well understood and all Symmetricom ovenized oscillators are designed to withstand exposure to greater than 300 krad (Si). The response to extremely low dose radiation (ELDRS) is a critical consideration because the ELDRS environment is more representative of the radiation environment than the oscillator. Electronic components and crystals need to be selected for optimum performance under low dose rates. The space environment includes several additional radiation exposure concerns. These include single event effects (SEE), neutron exposure, high dose rates and electron charging. Military space programs contain unique requirements that will guarantee performance under manmade nuclear events. Design techniques include provision that maintain output frequency and amplitude stability in prompt dose environments.

## ULTRASTABLE OSCILLATOR FOR THE LUNAR RECONNAISSANCE ORBITER (LRO)

Symmetricom has recently delivered Ultrastable oscillators for the LRO program. The LRO program's goals are to characterize the Moon's environment for future planned landings. The Symmetricom 9512 oscillator is the principal timekeeping instrument on the payload. The signal generated by the oscillator is used by the Lunar Orbiter Laser Altimeter (LOLA) and the Laser Ranger (LR). The laser altimeter will provide data to generate an extremely accurate geodetic topographically map of the Moon. The laser ranger will determine the position of the lunar orbiter with accuracies that enable mapping of the Moon's gravitational fields. Shown below are photographs of the 9512 LRO Master Oscillator.



## **CONCLUSIONS**

Ultrastable Oscillators are a critical component of satellite timing and communications systems. Continued improvements in performance have shown the ability to generate sub  $10^{-13}$  frequency stabilities and long-term accuracies of less than  $10^{-7}$ . Future missions for Ultrastable Oscillators will likely require improvement in performance. Symmetricom and other organizations in the community will continue seek refinements to our designs to deliver the highest-performance quartz oscillators possible.