

OPTO-ELECTRONIC OSCILLATOR STABILIZED BY A HYPERFINE ATOMIC TRANSITION

Dmitry Strekalov, David Aveline, Andrey B. Matsko
Robert Thompson, Nan Yu, and Lute Maleki
Jet Propulsion Laboratory, California Institute of Technology
4800 Oak Grove Drive, Pasadena, CA 91109-8099, USA

Abstract

Opto-electronic oscillator (OEO) is a closed-loop system with gain, in which part of the loop is implemented by an optical beam, and the rest by RF circuitry. The technological advantage of this approach over traditional all-RF loops in the gigahertz range comes from the fact that frequency filtering can be done far more efficiently in the optical range with respect to the RF modulation, than in the RF range. As a result, OEO can be made very compact, low power, and have superior stability. In this work, we report our preliminary results on using the phenomenon of coherent population trapping in ^{87}Rb vapor as an optical filter. Such a filter allows us to stabilize the OEO at the hyperfine splitting frequency of rubidium, thus implementing a novel type of frequency standard.

1 INTRODUCTION: OPTO-ELECTRONIC OSCILLATOR

Microwave oscillators capable of generating spectrally pure signals at gigahertz frequencies are important for communications, navigation, radar, precise tests and measurements, and other applications. Performance of these oscillators is limited by the achievable quality factor Q of their resonance elements and by their sensitivity to environmental perturbations.

High purity signals can also be obtained using techniques of photonics, which is free of some of the intrinsic limitations of ultra-high frequency electronics mentioned above. In particular, the opto-electronic oscillator (OEO) is a photonic device that can produce spectrally pure signals at many tens of GHz [1-7].

A generic scheme of the OEO is shown in Figure 1. Light from a laser is amplitude-modulated by an electro-optical modulator (EOM) and then is sent into a fiber delay line followed by a photonic filter and a photodiode. The microwave signal of frequency ω from the photo detector output is amplified and fed back into the EOM. This system oscillates if the amplification in the closed loop exceeds the loss. The microwave amplifier may be unnecessary if the EOM efficiency and the photodiode RF output are sufficiently high.

The function of the optical delay in an OEO is to store the microwave energy, in which sense it is equivalent to a microwave cavity in the usual high frequency oscillators. It determines both the free spectral range (FSR) Ω_{FSR} of the resonator modes and their frequency width $\Delta\omega$. The longer is the fiber, the higher is the quality factor $Q = \frac{\omega}{\Delta\omega}$. However, a long optical delay line has a small FSR and supports many microwave frequencies carried by the optical beam. A narrow bandpass photonic filter following the delay line allows for selecting a single RF frequency and helps to achieve a stable single mode operation, as illustrated in Figure 2(a). In this case, the spectral purity and the stability of the oscillations are determined by the resonator linewidth, but they also may be determined by the filter, if the latter has narrower width than the resonator mode; see Figure 2(b).

Previously, we have implemented the case (a) of Figure 2 with an RF filter used instead of a photonic filter, and measured stability of such an OEO. The results of those measurements are shown in Figure 3. Although we have achieved relatively high spectral purity of the signal, it nevertheless is limited by high sensitivity of the long fiber delay line to the environment, so the OEO in this configuration does not have very good long-term stability. It is typically phase-locked to a stable reference.

To further improve the OEO performance, we now propose using a photonic filter based on the effect of Electromagnetically Induced Transparency (EIT) [8-10]. The steep frequency dispersion near a narrow EIT resonance has been used to produce ultraslow group velocity of light [11,12] in atomic vapors [13-15] as well as in doped solids [16,17]. The narrow EIT resonances also have proved useful for construction of all-optical miniature atomic clocks [18]. Now we will show that they could also be useful for OEO stabilization. To make the most efficient use of EIT for OEO, we notice that the EIT resonances can be as narrow as the resonator modes with many kilometers of fiber. However, unlike the modes of a resonator with a long fiber, the EIT resonance frequency is not affected by environmental changes. Moreover, when the EIT is based on the $m_F = 0 \rightarrow m_{F'} = 0$ transition of different hyperfine states F and F' (the so-called clock transition), its resonance provides a natural frequency reference that can be used as an etalon. To take advantage of this, we have demonstrated a realization of case (b) of Figure 2. In this case, the spectral properties of the oscillations will be primarily determined by the atomic filter, and long optical delay will be unnecessary.

2 OUR EXPERIMENT

The experimental setup of the EIT-stabilized OEO is shown in Figure 4. We use the $5S_{1/2}, F=2 \rightarrow 5P_{1/2}, F=1$ and $5S_{1/2}, F=1 \rightarrow 5P_{1/2}, F=1$ transitions of ^{87}Rb to form the “ Λ -system.” This is a configuration of two ground states coupled to an excited state, which is known to exhibit the EIT phenomenon. The transition frequencies differ by 6.83468 GHz, which is going to be the RF frequency ω of our oscillator.

The dual-pass acousto-optical modulator (AOM) and a standard saturation spectroscopy setup allow us to lock the pump laser with approximately 300 MHz offset to the red from the $F = 2 \rightarrow F = 1$ transition. This detuning turned out to be optimal for the OEO operation of our system. Most likely, it is determined by the off-resonance absorption of the ^{85}Rb isotope that suppresses the EIT as we tune the laser wavelength close to the transition.

The laser light passes through an electro-optical phase modulator (EOM), a set of waveplates, and a polarizer to produce amplitude modulation. Having amplitude modulation is important, because in case of pure phase modulation, the beat signal carrier produced with one sideband cancels the beat signal it produces with the other sideband. The amplitude-modulated light then passes through a rubidium cell. The cell is 2 inches long and contains a natural mixture of rubidium isotopes. In these experiments, the cell temperature was set to about 105°C. The cell is placed inside of a solenoid, which is used to create a magnetic field along the propagation direction of the optical beam. The solenoid and the cell are enclosed in a three-layer μ -metal shield.

Light that passes through the cell is detected by a fast photodiode, whose RF output is coupled to the EOM through an amplifier and a phase shifter. Part of the microwave signal is directed to a spectrum analyzer to monitor the oscillation amplitude and frequency.

Before setting up the OEO oscillation, we obtained the frequency response functions of our system by driving the EOM with an external sweeping RF synthesizer. The response signal is obtained by mixing the photodiode signal with the local oscillator signal, i.e. by a heterodyne measurement. During this measurement, we can apply DC magnetic field along the cell. The Zeeman shifts of magnetic sublevels m_F have opposite signs for $F = 1$ and $F = 2$, and all transitions from $F = 1$ manifold to $F = 2$ manifold are therefore detuned from the two-photon resonance, except for the clock transition $m_1 = 0 \rightarrow m_2 = 0$.

The measurement results are shown in Figure 5. On the left part of the Figure, the magnetic field is small, and in addition to the central peak $m_1 = 0 \rightarrow m_2 = 0$ we see two other peaks. On the right part, the field is several Gauss strong, and the side peaks are outside the sweep range. Such a strong magnetic field is on in all the experiments described below. Fitting the single peak to a Lorentzian, we find its width to be approximately 230 kHz.

Next, we remove the synthesizer and connect the photodiode to the amplifiers, closing the feedback loop that gives rise to self-sustaining oscillation. When the EIT is achieved, the oscillation frequency is locked to the atomic hyperfine transition.

The EIT-stabilized regime can be achieved only within a fairly narrow range of the laser wavelength, confirming that the atoms perform the function of a photonics filter. To illustrate the effect of laser wavelength tuning on the OEO operation, we slowly scanned the wavelength while measuring the integrated photodiode signal. The result is given in Figure 6, which represents the red slope of Doppler absorption profile. We see two wavelength ranges where oscillations occur: the one on the red side corresponds to stable oscillation and is accompanied by a higher transmission (due to EIT); the one on the blue side corresponds to unstable oscillations and is accompanied by higher noise.

The stable oscillations spectrum is shown in Figure 7. We see that its width is approximately 1 kHz, which is much narrower than the EIT filter width. The peak in Figure 7 can drift within approximately ± 500 kHz before the oscillations become unstable and disappear. This range is consistent with the EIT width. This regime of operation is similar to that of the CPT clocks [18], and the situation can be improved by obtaining a narrower EIT signal.

3 DISCUSSION AND CONCLUSION

Using an atomic cell instead of an optical fiber delay or a cavity for stabilizing an OEO is advantageous for construction of frequency references. This is because, in the latter case, the frequency of the OEO depends on the external conditions while the splitting of the atomic ground state is fixed, and has less sensitivity to the same influences that perturb a fiber. Furthermore, an atomic cell is more tolerant to the absolute pump laser stability than, e.g., an optical cavity. If light with a broad linewidth propagates through a high-Q cavity, the phase fluctuations of the input light are converted to the amplitude fluctuations at the output. This conversion affects the stability of oscillations. In turn, the acceptable linewidth of the pump light used in an OEO with an atomic cell is determined by the width of atomic spectral line and is often much wider than the width of the two-photon resonance, which is used for OEO stabilization.

On the other hand, unlike an ideal cavity where transmission does not depend on the cavity quality factor, the atomic cell absorbs light. The maximum transmission (achieved when the modulation frequency of the light is equal to the frequency of the ground state splitting of the atoms) is related to the width of the two-photon resonance.

In this paper, we have shown that the OEO with an atomic cell filter is capable of generating stable microwave signals at a frequency determined by the filter. We report an experimental demonstration of an OEO stabilized with a Rb atomic vapor cell. Because such a device can be miniaturized and has a potentially high stability, the present study is a step toward the creation of a miniature atomic frequency reference based on the OEO architecture.

4 ACKNOWLEDGMENTS

The research described in this paper was carried out by the Jet Propulsion Laboratory, California Institute of Technology, under a contract with the National Aeronautics and Space Administration, with support from the DARPA CSAC Program.

5 REFERENCES

- [1] X. S. Yao and L. Maleki, 1996, "Optoelectronic microwave oscillator," **Journal of the Optical Society of America**, **B 13**, 1725-1735.
- [2] Y. Ji, X. S. Yao, and L. Maleki, 1999, "Compact optoelectronic oscillator with ultralow phase noise performance," **Electronics Letters**, **35**, 1554-1555.
- [3] T. Davidson, P. Goldgeier, G. Eisenstein, and M. Orenstein, 1999, "High spectral purity CW oscillation and pulse generation in optoelectronic microwave oscillator," **Electronics Letters**, **35**, 1260-1261.

- [4] S. Romisch, J. Kitching, E. Ferre-Pikal, L. Hollberg, and F. L. Walls, 2000, “*Performance evaluation of an optoelectronic oscillator*,” **IEEE Transactions on Ultrasonics, Ferroelectrics, and Frequency Control**, **47**, 1159-1165.
- [5] X. S. Yao and L. Maleki, 2000, “*Multiloop optoelectronic oscillator*,” **IEEE Journal of Quantum Electronics**, **36**, 79-84.
- [6] S. Poinot, H. Porte, J. P. Goedgebuer, W. T. Rhodes, and B. Boussert, 2002, “*Continuous radio-frequency tuning of an optoelectronic oscillator with dispersive feedback*,” **Optical Letters**, **27**, 1300-1302.
- [7] D. H. Chang, H. R. Fetterman, H. Erlig, H. Zhang, M. C. Oh, C. Zhang, and W. H. Steier, 2002, “*39-GHz optoelectronic oscillator using broad-band polymer electrooptic modulator*,” **IEEE Photonic Technology Letters**, **14**, 191-193; *ibid.*, **14**, 579-579.
- [8] E. Arimondo, 1996, “*Coherent population trapping in laser spectroscopy*,” **Progress in Optics**, **35**, 257-354.
- [9] S. E. Harris, 1997, “*Electromagnetically induced transparency*,” **Physics Today**, **50**, 36-42.
- [10] J. P. Marangos, 1998, “*Topical review on electromagnetically induced transparency*,” **Journal of Modern Optics**, **45**, 471-503.
- [11] A. B. Matsko, O. Kocharovskaya, Y. Rostovtsev, G. R. Welch, A. S. Zibrov, and M. O. Scully, 2001, “*Slow, ultraslow, stored, and frozen light*,” **Advances in Atomic, Molecular, and Optical Physics**, **46**, 191.
- [12] R. W. Boyd and D. J. Gauthier, 2002, “*Slow and Fast Light*,” **Progress Optics**, **43**, 497-530.
- [13] L. V. Hau, S. E. Harris, Z. Dutton, and C. H. Behroozi, 1999, “*Light speed reduction to 17 metres per second in an ultracold atomic gas*,” **Nature**, **397**, 594-598.
- [14] M. M. Kash, V. A. Sautenkov, A. S. Zibrov, L. Hollberg, G. R. Welch, M. D. Lukin, Y. Rostovtsev, E. S. Fry, and M. O. Scully, 1999, “*Ultraslow group velocity and enhanced nonlinear optical effects in a coherently driven hot atomic gas*,” **Physical Review Letters**, **82**, 5229-5232.
- [15] D. Budker, D. Kimball, S. Rochester, and V. Yashchuk, 1999, “*Nonlinear magneto-optics and reduced group velocity of light in atomic vapor with slow ground state relaxation*,” **Physical Review Letters**, **83**, 1767-1770.
- [16] A. V. Turukhin, V. S. Sudarshanam, M. S. Shahriar, J. A. Musser, B. S. Ham, and P. R. Hemmer, 2002, “*Observation of ultraslow and stored light pulses in a solid*,” **Physical Review Letters**, **88**, 023602.
- [17] M. S. Bigelow, N. N. Lepeshkin, and R. W. Boyd, 2003, “*Observation of ultraslow light propagation in a ruby crystal at room temperature*,” **Physical Review Letters**, **90**, 113903.
- [18] J. Kitching, S. Knappe, and L. Hollberg, 2002, “*Miniature vapor-cell atomic-frequency references*,” **Applied Physics Letters**, **81**, 553-555.

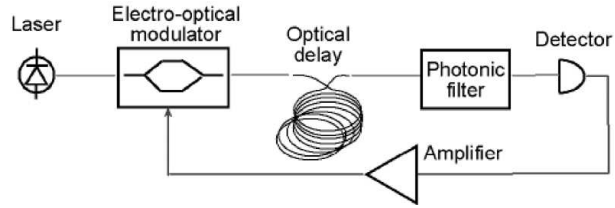

Figure 1: Conceptual drawing of the OEO.

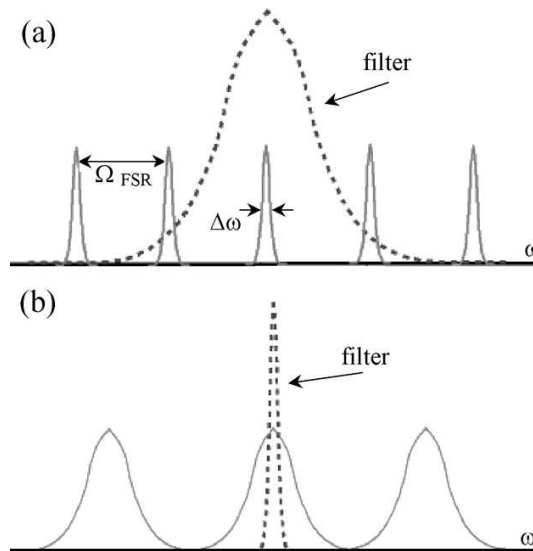

Figure 2: Illustration of the frequency selection in the OEO. Solid lines are the resonator modes, dashed line is the filter function which can be either broader (a), or narrower (b) than a resonator mode.

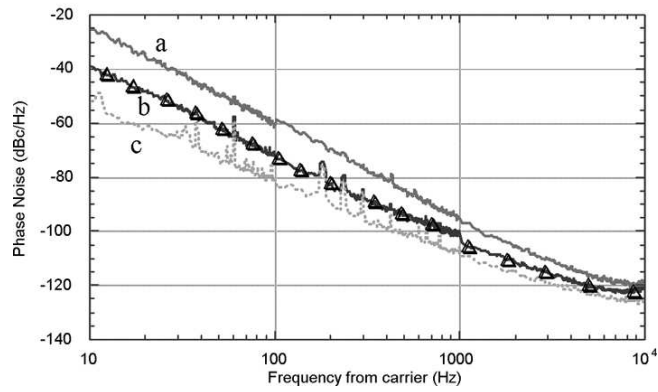

Figure 3: Phase noise of an OEO with RF filter and 2 km of fiber (a); 4 km of fiber (b); and 6 km of fiber (c).

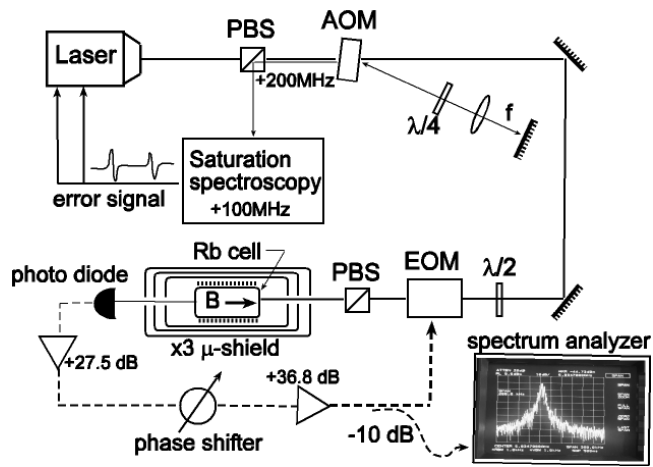

Figure 4: Experimental setup for demonstration of the EIT-stabilized OEO.

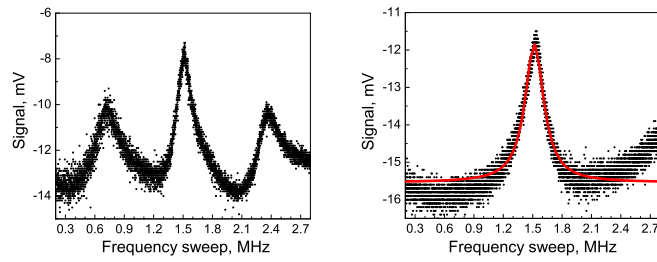

Figure 5: Frequency response of the EIT filter obtained by heterodyne measurement technique. On the left: for a weak magnetic field, peaks corresponding to transitions between different Zeeman levels are visible; on the right: for a strong field, only the $m_1 = 0 \rightarrow m_2 = 0$ peak is present.

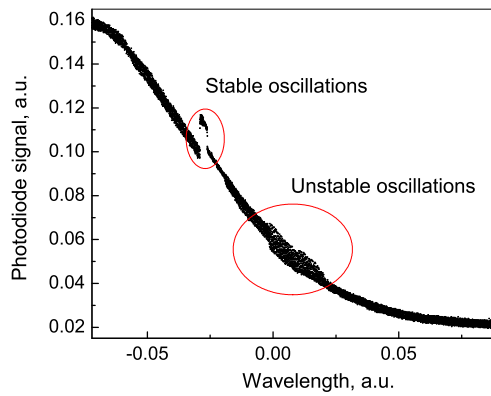

Figure 6: Rubidium cell transmission signal on the red wing of Doppler broadened line (the entire scan is approximately 700 to 800 MHz wide). Irregular segments indicate the ranges of OEO oscillations.

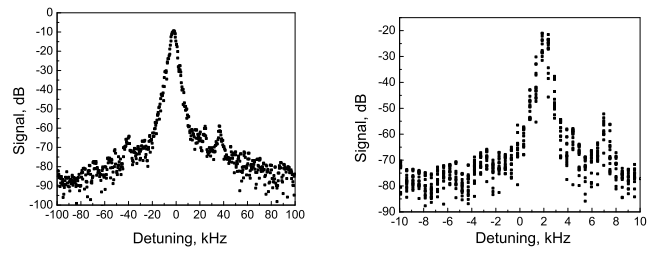

Figure 7: On the left: the RF spectrum with a resolution limited by the spectrum analyzer bandwidth. On the right: the same with higher resolution, yielding the RF spectral width of approximately 1 kHz. The zero detuning corresponds to the hyperfine transition frequency $\omega_M \approx 6.8$ GHz.

QUESTIONS AND ANSWERS

JIM CAMPARO (The Aerospace Corporation): Did I see on one of the charts that you showed a phase diffusion coefficient. Then underneath the chart it said “50 times larger than anticipated.”

LUTE MALEKI: Actually, it isn't. Again, I apologize because this particular talk is several months old. At the time, we got a number of different things that we were wondering what they were. It turns out that it can all be traced to the fact that we had sort of a mixture of isotopes and a mixture of laser and everything else.

CAMPARO: So it really wasn't real?

MALEKI: No.