

# THE EXPERIMENTAL PRECISE TIMING STATION (E-PTS) FOR THE GALILEO SYSTEM TEST BED (PHASE V1): ARCHITECTURAL DESIGN AND EXPERIMENTAL GOALS

**E. Detoma, S. Facioni, M. Gotta, G. Graglia**  
Alenia Spazio S.p.A., Italy

**F. Cordara, L. Lorini, V. Pettiti, P. Tavella**  
Istituto Elettrotecnico Nazionale (IEN) “G. Ferraris,” Italy

**J. Hahn**  
ESA/ESTEC, The Netherlands

## Abstract

*The Galileo System Test Bed (GSTB) V1 has two main objectives:*

- *conduct experimentation as soon as possible in order to provide feedback to the definition of critical algorithms (Orbit Determination and System Time Synchronization [OD&TS], integrity, etc.) in the Galileo Design and Development Phase;*
- *set up the core infrastructure required to conduct the experimentation.*

*In the framework of the GSTB V1, the implementation of the Experimental Precise Timing Station (or E-PTS for short) is important, since it will allow the realization of the Experimental Galileo System Time (E-GST) and the test of different algorithms to ensure stability and accuracy of the resulting time scale.*

*The E-PTS will be implemented at the Istituto Elettrotecnico Nazionale (IEN), Turin, Italy using the facilities and personnel of the Time & Frequency laboratory, under the responsibility of Alenia Spazio for the Galileo Industries, which is prime contractor for the GSTB V1 phase under an ESA contract. The work will be carried on with the direct participation of two major European national laboratories, the Physikalisch Technische Bundesanstalt (PTB - Germany) and the National Physical Laboratory (NPL - UK).*

*The authors provide an overview of the GSTB V1 phase, the architecture of the E-PTS and the main experiments supported by the facility for the development of the Galileo navigation system.*

## THE GALILEO SYSTEM TEST BED (GSTB) V1

During the GalileoSat Definition Phase, a Galileo System Test Bed (GSTB) has been defined as an integral part of the Galileo Design Development and Validation Phase in order to mitigate program risks.

The GSTB is subdivided in two main development steps, Version 1 (V1) and Version 2 (V2), with the following aims:

### GSTB V1

Measurements from the GPS system are collected to verify the Galileo concepts for Orbit Determination & Time Synchronization and Integrity. During GSTB V1 development, collaboration with the International GPS Service (IGS) community and UTC Time Community is established. Furthermore, interfaces with the EGNOS System Test Bed (ESTB) and other GPS-related national infrastructures are foreseen.

### GSTB V2

GSTB V2 will consist of an experimental Galileo satellite to be launched by the end of 2004 and an extension of GSTB V1, including Galileo receivers and real-time processing algorithms [1].

The GSTB V1 primary objective is to conduct experimentation as soon as possible in order to provide feedback to the definition of the critical algorithms in the Galileo Design Development and Validation Phase. The fulfillment of this primary objective requires as a secondary objective setting up the core infrastructure required to conduct the experimentation. The European Space Agency has specified a list of experiments (so-called Test Cases) to be performed in GSTB V1, addressing:

- Orbit Determination and Time Synchronization (OD&TS) algorithms performance assessment and comparison of alternative methods;
- E-PTS infrastructure setup;
- E-GST steering to Universal Time Coordinated (UTC)/ International Atomic Time (TAI);
- User Equivalent Range Error (UERE) budget characterization;
- Signal in Space Accuracy (SISA) computation algorithm and Integrity Flag (IF) computation performance assessment.

Based on the above Test Case requirements, a ground-segment Core Infrastructure is developed and deployed in order to conduct the experimentation in a suitable environment to fulfill the test case objectives using GPS measurements and simulators to extrapolate results to Galileo.

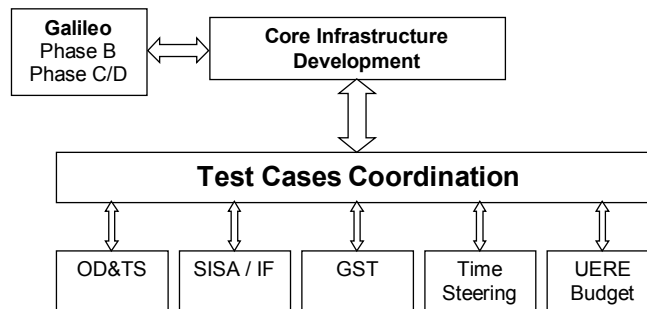

Figure 1. Test Case coordination.

The GSTB V1 Core Infrastructure is not intended to be used in the final Galileo system, but as one of several means to bring added value in terms of confidence, design consolidation, and accelerated schedule. The GSTB V1 experimentation will demonstrate the validity and feasibility of some of the important assumptions and performance objectives of the final Galileo system.

The GSTB V1 Core Infrastructure is made up of a ground segment providing the environment for test case experimentation, in particular providing the input data to the algorithms under test and storing the

output core products. It guarantees a consistent approach between the OD&TS, the timing, and the integrity tests, managing the configuration so that all test case data sets and results are conveniently traceable and can be disseminated to external users on request.

The GSTB V1 Core Infrastructure implements the following functions (Figure 2):

- GPS raw measurements and navigation data acquisition for OD&TS and SISA/IF experimentation;
- Data communication from the sensor stations to the GSTB V1 Processing Center (GPC);
- Data formatting, archiving, and distribution in the GPC, with the objective of achieving a consistent process for OD&TS, GST, and integrity;
- Data processing in the GPC, generating most of the core products;
- Precision timing, including in particular the generation and maintenance of an Experimental Galileo System Time (E-GST). This function includes the E-GST steering to UTC/TAI (k).

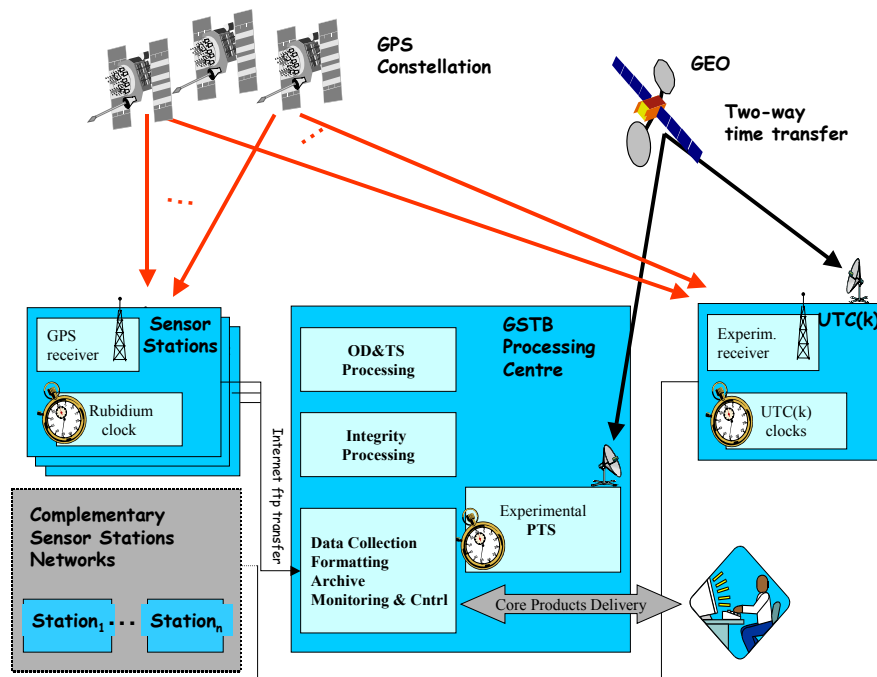

Figure 2. The GSTB V1 Core Infrastructure.

## THE EXPERIMENTAL PRECISE TIMING STATION (E-PTS)

The E-PTS is intended to provide a physical realization of the Experimental Galileo System Time (E-GST) and to exercise the algorithms to generate, synchronize, and steer the resulting E-GST time scale to TAI. The E-GST will be provided as a time reference for the OD&TS process. The E-PTS will be in charge of:

- the operations of the atomic clock ensemble, by verifying the correct functioning of all the elements;
- the setup, calibration, and operation of the local measurement systems aiming at measuring the clock differences;
- the use of the above measures in a time scale algorithm to calculate the ensemble time scale E-GST and to check the correct behavior of each clock;
- the installation, verification, and calibration of the remote measurement systems, ensuring the link of E-GST versus the external UTC (k) labs and the GPC. The time transfer links are comprised of:
  - GPS geodetic measurements;
  - GPS Common-View (CV) timing measurements;
  - Two-Way Satellite Time and Frequency Transfer (TWSTFT) measurements.
- the operation of the above remote measurement systems to obtain the measurements of UTC(k) – E-GST, where k stands for PTB and NPL;
- the processing of the comparison measurements to estimate the offset of E-GST versus UTC and TAI and to identify the proper steering corrections;
- physically steering the output of a H-maser to realize E-GST;
- the collection, verification, and processing of all the experimental data to evaluate the performance of E-GST;
- sending of raw data, intermediate data, and final test result data to Galileo Processing Centre (GPC) for other experimentation use and archiving.

In order to accomplish all these tasks and in addition to allow experimental activities to take place, a suitable architecture has been devised and shown in Figure 3. The aim is to maximize the reuse of existing equipment whenever possible, i.e.: when the E-PTS operations do not conflict with the routine IEN Time and Frequency Laboratory activities.

The proposed architecture fulfills the following purposes:

- provide a redundant clock ensemble for the generation of the E-GST reference;
- provide a state-of-the-art measurement and data acquisition system capable of monitoring in real time the clock performance and of feeding the relevant data to the algorithms that will be used to construct E-GST;
- provide a physical realization of E-GST by controlling the output of one of the available clocks via a precision phase micro-stepper (the auxiliary offset generator or AOG);
- provide high-accuracy synchronization links to external laboratories (IEN, PTB, NPL) to allow steering the E-GST to TAI. Synchronization links to remote laboratories are provided by state-of-the-art two-way and common-view GPS time transfer receivers;
- provide a direct reference of E-GST to the OD&TS functions via a dedicated GPS geodetic receiver (feeding ranging data to the OD&TS) driven by the physical realization of E-GST;
- provide a convenient framework for algorithms and experiments debugging and testing.

The setting up and operation of a “local measurement system,” inside the E-PTS, has the double aim of providing clock data for the computation of E-GST and for the monitoring of the clocks as described above.

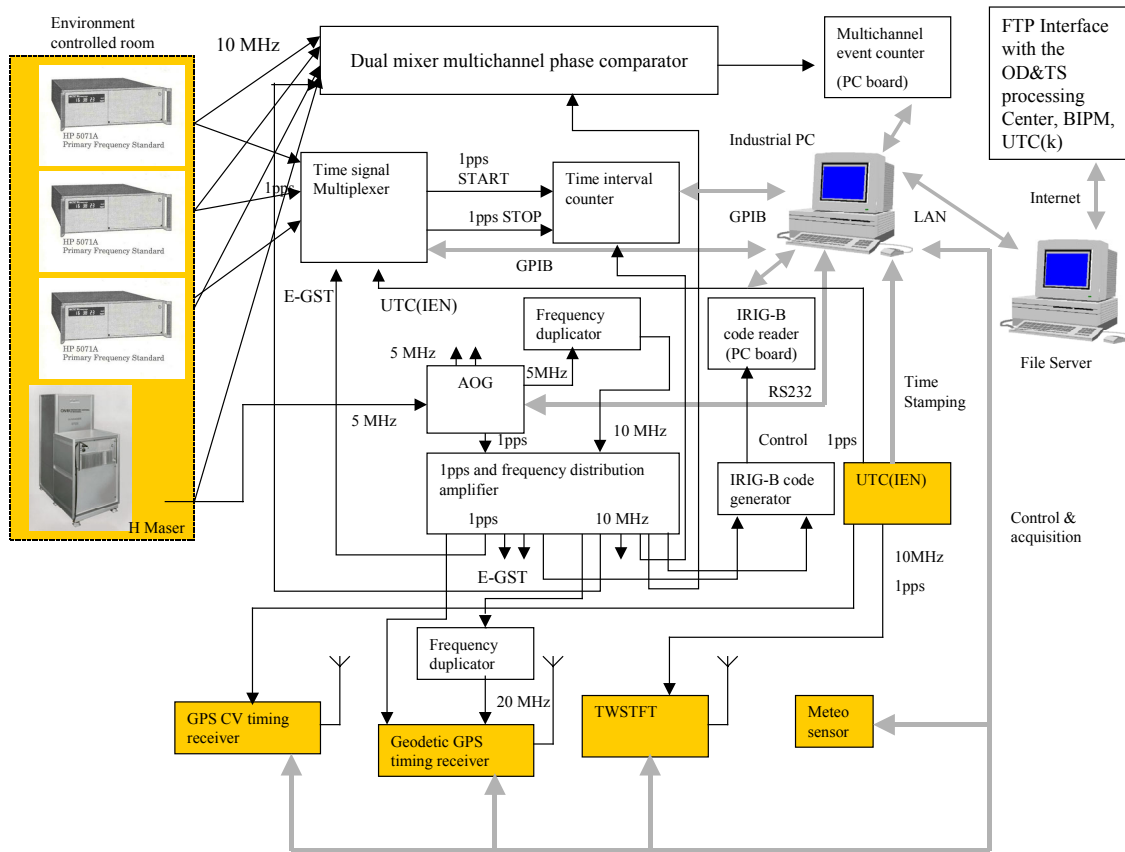

Figure 3. E-PTS architecture.

The local measurement system consists of two parallel systems:

1. a primary system, based on a 1 pps signal multiplexer followed by a high-resolution time interval counter. Since the measurements are performed on the 1 pps signals, which are generated by the local clocks; this system allows one to compare the clocks in sequence with a measurement resolution of 25 ps. The accuracy depends also on other factors as the trigger instant, the quantization error, and the time base error, and it may amount to a few hundreds of picoseconds.
2. a secondary system, based on a dual mixer multi-channel phase comparator, that allows one to compare all the clocks *simultaneously*, with a resolution of 1 to 10 ps and with a *noise floor* of around  $5 \cdot 10^{-13}$  at 1 second. The simultaneity of the measurements and the continuity of the data acquisition at a relatively high data rate make it an ideal tool for real-time monitoring of the clock ensemble, frequency stability computations, and anomalies detection.

The E-GST generation and clock monitoring functions will be performed by a local computer, an industrial PC, fed with measurements both from the multiplexed time interval counter (TIC) and from the multi-channel phase comparator.

The physical implementation of E-GST will be realized by feeding the appropriate corrections to the auxiliary offset generator (or AOG, which is a precision phase micro-stepper) driven by the active H-maser. The resulting 1 pps and 5 MHz signals represent E-GST. The 5 MHz is frequency doubled to 10 MHz prior to distribution to the user via suitable distribution amplifiers designed to ensure the integrity of the signals. An IRIG-B code generator will provide a coded-representation of E-GST to the PC, allowing

the time tagging of the data in the E-GST time scale. The UTC steering will be realized using the measurement system based on the multiplexer and the time-interval counter.

The core products and E-PTS status will be made available to the GPC via an Internet connection supported by a local server; the same connection will allow exchange of messages from the GPC to the E-PTS operators via e-mail or ftp.

## THE TEST CASES

The *Experimental Galileo System Time* is generated according to the scheme in Figure 4 and it is divided into two steps:

1. The ensemble of the E-PTS cesium clocks is evaluated according to a stability algorithm studied in the Galileo Phase B2. From such ensemble the drift of the H-maser is estimated. From the comparison versus UTC, the correction to be given to the H-maser to match TAI is also estimated;
2. From the above-estimated corrections, a frequency steering is imposed to the H-maser through the AOG and the therefore corrected output of the H-maser is the physical implementation of E-GST.

At a second stage, the number of clocks in the ensemble is augmented by using also additional IEN, PTB, and NPL clocks. This test has the aim of evaluating the benefit/drawback of using more clocks available from external laboratories that could collaborate with the operative Galileo system.

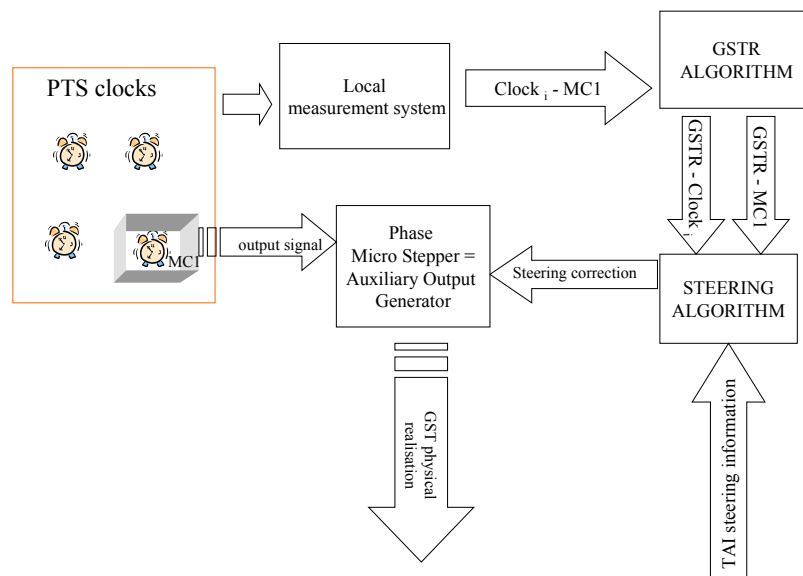

Figure 4. Scheme of the generation of E-GST.

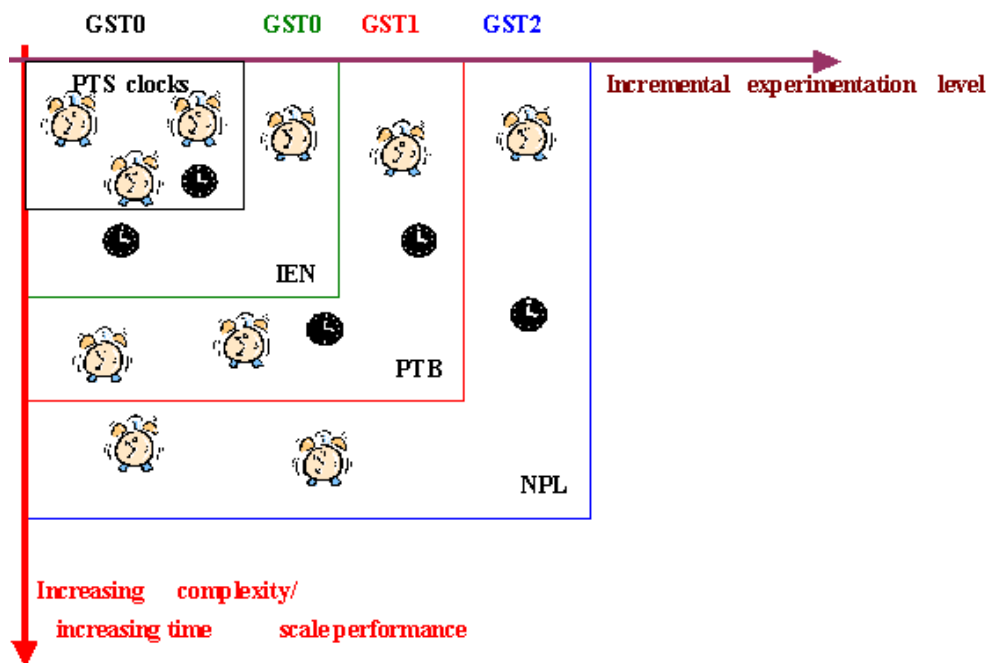

Figure 5. Addition of external clocks.

In addition, to assess the characteristics of the E-GST generation algorithm, two different alternative algorithms will be implemented and tested on the same clock data. These are the:

1. the NIST AT1 algorithm;
2. GPS-like Composite Clock algorithm.

These two alternative algorithms are based on different approaches, and the three algorithms so far identified and tested cover to a good extent all the different time scale algorithms in use today.

As a second Test Case, *the steering to TAI* has to be accomplished and to this aim a connection to the UTC community is necessary. This is done by linking E-GST to UTC (PTB) and UTC (NPL) by means of GPS Common View and TWSTFT as depicted in Figure 6. By the results of BIPM Circular T linking UTC to UTC (k), the link of E-GST to TAI is thus ensured.

This test has the double aim of testing the one-way versus two-way synchronization techniques and also of evaluating the capability of predicting the international TAI to steer the E-GST H-maser.

The TAI prediction will be performed by means of a linear extrapolation of past BIPM data, but it has been also proposed, as a research activity, to use the IEN cesium fountain to steer the E-GST. In fact, TAI is the international reference time scale whose frequency is adjusted to be in agreement with the best realizations of the *second* of the *Système International* (SI). The best realization of the second is provided by the primary frequency standards that are operated in the different national metrological laboratories and that, presently, can reach a relative accuracy of a few units in  $10^{-15}$  with a vertical setup called “cesium fountain” (Figure 7).

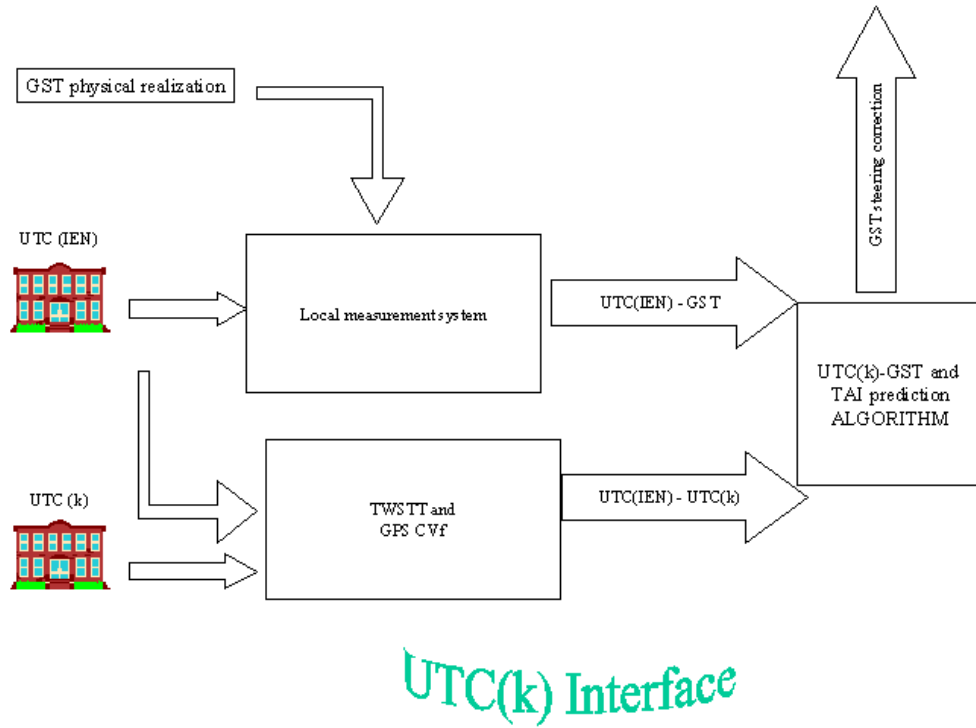

Figure 6. Scheme of the connection of E-GST to UTC.

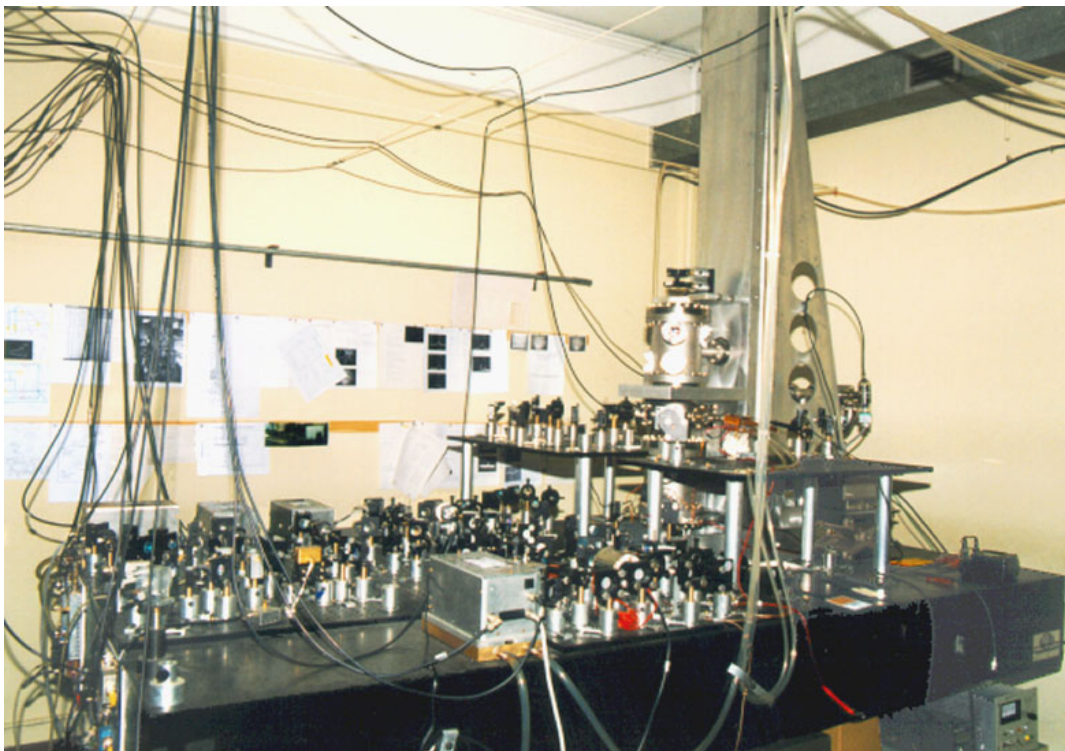

Figure 7. The IEN cesium fountain.



The primary standards provide the “standard” frequency corresponding to the frequency of any time scale based on the SI second; therefore, a frequency standard can help in calibrating the frequency of GST and in keeping it in agreement with TAI frequency. The link with a UTC (k) time scale is necessary for knowing and compensating the offset in time between TAI and E-GST, while a frequency standard can help in maintaining the correct time synchronization by keeping the frequency at the correct value.

By means of an appropriate statistical treatment, the stability and accuracy of the resulting E-GST together with all its different versions will be accomplished.

## **RELATIONSHIP BETWEEN GALILEO AND GSTB V1**

A focal point to be highlighted is that Galileo and GSTB V1 run in parallel. On the one hand, the Galileo program supplies the critical concepts to be verified within the GSTB V1 framework. On the other hand, GSTB V1 returns the demonstrated data and the processed concepts to the Galileo definition phase.

GSTB V1 is a program that aims at verifying the critical concepts of Galileo and returns feedback to the Galileo definition phase. In this view, a correct synchronization between the two programs is paramount. As a consequence, a big effort in optimizing the GSTB V1 schedule was made in order to have the data when necessary for Galileo, and vice versa. In the E-PTS development, the significant features are:

- maximum reuse of existing facilities and components;
- reuse of methodologies and software components already in use in an operational environment (the IEN time and frequency laboratory; see Figure 8) with final requirements very similar to those envisaged for the E-PTS;
- availability of qualified personnel skilled in the development of state-of-the-art timing equipment and timekeeping operations.

In addition to the attempts undertaken to ensure a harmonization between the two programs, a tight collaboration must be ensured in order to have a correct and bilateral information flow.

According to the present schedule, the E-PTS will supply raw data [based on UTC (IEN)] starting from April 2003, and will become fully operative from August-September 2003.

## **THE INDUSTRIAL CONSORTIUM**

GSTB V1 is an ESA program, and the prime contractor is Galileo Industries (GAIN); Galileo Industries is a joint company between Alenia Spazio, Alcatel Industries, Astrium GmbH, Astrium Ltd., and a consortium of Spanish companies (GMV, Indra, ...).

The E-PTS, one of the GSTB V1 elements, is under the responsibility of Alenia Spazio. The companies and institutions involved in the E-PTS development are: Alenia Spazio, Istituto Nazionale “Galileo Ferraris” (IEN - Italy), the National Physical Laboratory (NPL, U.K.), and the Physikalisch Technische Bundesanstalt (PTB – Germany).



Figure 8. The IEN Time and Frequency Laboratory.

## CONCLUSIONS

The GSTB V1 is the first experimental test on the Galileo system. The architecture and Test Cases are designed in order to evaluate the criticality of the algorithms for the Galileo system. Nevertheless, concerning PTTI activities, the timing test cases in the GSTB may give interesting results on the use of different clocks, primary standards, measurement systems, and algorithms that may hopefully have some value to the PTTI community.

## ACKNOWLEDGMENTS

The authors wish to thank Mr. Marco Falcone of ESA/ESTEC and all the colleagues from ESA, GaIn, Alenia, and IEN for the invaluable help that they are receiving every day in setting up this project.

## REFERENCES

- [1] M. Falcone, F. Amarillo-Fernandez, J. Hahn, and H. Favin-Leveque, 2003, "*The GALILEO System Test Bed for Early Prototyping and Experimentation of GALILEO Algorithms*," in Proceedings of the ION GPS 2002 Meeting, 24-27 September 2002, Portland, Oregon, USA (Institute of Navigation, Alexandria, Virginia), pp. 2148-2159.
- [2] M. Falcone, R. Lucas Rodriguez, F. Emma, and J. Hahn, "*The GALILEO System Test Bed (GSTB)*," in Proceedings of the GNSS 2001 Conference, 8-11 May 2001, Seville, Spain.

- [3] E. Breeuwer, R. Franco, M. Falcone, J. C. De Mateo, P. Erhard, and N. M. Hollreiser, 2002, “*Simulation and Experimentation in the GALILEO System Design and Verification,*” in Proceedings of the GNSS 2002 Conference, 27-30 May 2002, Copenhagen, Denmark.

## QUESTIONS AND ANSWERS

**DEMETRIOS MATSAKIS (U.S. Naval Observatory):** This is a little after, but I had this discussion with several people and not with you. And I wonder what you think. Is there any consideration in the algorithms being given to having the European timing labs become the Galileo monitor stations, at least in Europe? So if they are one in the same and there is no Galileo monitor station in Europe, that is not a timing lab.

**EDOARDO DETOMA:** Yes, there have been a lot of discussions about this possibility. And currently the opinions are changing rapidly, so I hope to give you the last stages. Basically, what ESA wants is to keep the control of the navigation capabilities of the system. That means the generation of the system time for navigation purposes only. The idea is to subcontract outside the steering of the navigation time scale to UTC or TAI for timing purposes. And at this point, possibly a national laboratory or some other organization can act in this way. From the point of view of navigation, there is absolutely no reason to steer a navigation time scale or to keep a navigation time scale synchronized to anything else. Except the only concern is to keep it uniform and stable.

It is debatable whether subcontracting this function to somebody else is a useful procedure or not. But certainly, the timing function can be delegated to some other organization and not be kept in the charge of whoever, ESA or a private subcontractor, will be operating the Galileo system.