

FAST “DIRECT-P(Y)” GPS SIGNAL ACQUISITION USING A SPECIAL PORTABLE CLOCK

Hugo Fruehauf
Zyfer Inc., an Odetics Company
1585 S. Manchester Ave.
Anaheim, CA 92802-2907, USA
Tel: 714-926-5134; E-mail: hxf@zyfer.com

Abstract

“What goes around comes around,” we have heard it said, and it seems that this is the case for precision Portable Clocks as well. Twenty years ago, the only effective way to transfer Universal Coordinated Time (UTC) from one geographic location to another was with a Portable Clock. Since the advent of GPS however, UTC dissemination is done via satellites, virtually eliminating Portable Clocks. But now a new element is looming on the horizon, which may breathe new life into applications of such devices. This relates to the GPS P(Y)-Code, which is the secure military crypto-keyed signal providing what is referred to as the “Precise Positioning Service” (PPS). More specifically, however, is what a Portable Clock can do to enhance the new functionality of the P(Y)-Code signal acquisition called “Direct-P(Y)”, in an environment where the civil C/A-Code signal is not available. Direct-P(Y) refers to the ability for the military receiver to come online without the aid of the civil (in the clear) C/A-Code signal.

The Portable Clock can play an important role in quick acquisition of the P(Y)-Code signal, a significant crew safety consideration for our soldiers in the field. No matter what the operational scenario may be, the Portable Clock proves to be an invaluable tool for Direct-P(Y) terminals. For those about to enter hostile territory, “no-one should leave home without one.”

THE NEW WARFARE REALITIES

With the civil GPS market fully entrenched and fast becoming a multi-billion dollar commercial business, the government recently turned off SA. SA (Selective Availability) is a deliberate degradation of accuracy of the civil C/A signal. SA, which can be set to any level desired by U.S. military planners, had been set to approximately 100 meters navigation uncertainty and 1 microsecond time error for the past 20 years. With SA set to zero, the full civil navigation and time accuracy can now be realized, being about 10 meters or less and 100 nanoseconds or less most of the time. In the unlikely event of a strategic conflict, SA helps to protect our forces against the use of commercial GPS receivers by our enemies. In such a conflict, military planners would simply crank-up the SA to 500 meters or more. This makes the C/A signal useless for commercial navigation, but still available to aid in the acquisition process of the military crypto P(Y)-Code signal.

Today, however, strategic conflicts are less likely, but tactical ones are high on the probability list. In such conflicts, it is simpler to jam the civil C/A signal in the local area, affecting only local commercial GPS receivers. This is a very effective way of dealing with the problem, because activating SA (in place

of local jamming) would deny civil navigation worldwide. The issues with strategic and tactical warfare scenarios are illustrated in Figure 1.

There is one problem, however; the military P(Y) signal acquisition requires that the C/A signal is available to give the receiver an approximate 100 nanoseconds UTC time reference. So, how does local

Figure-1, The New Warfare Realities

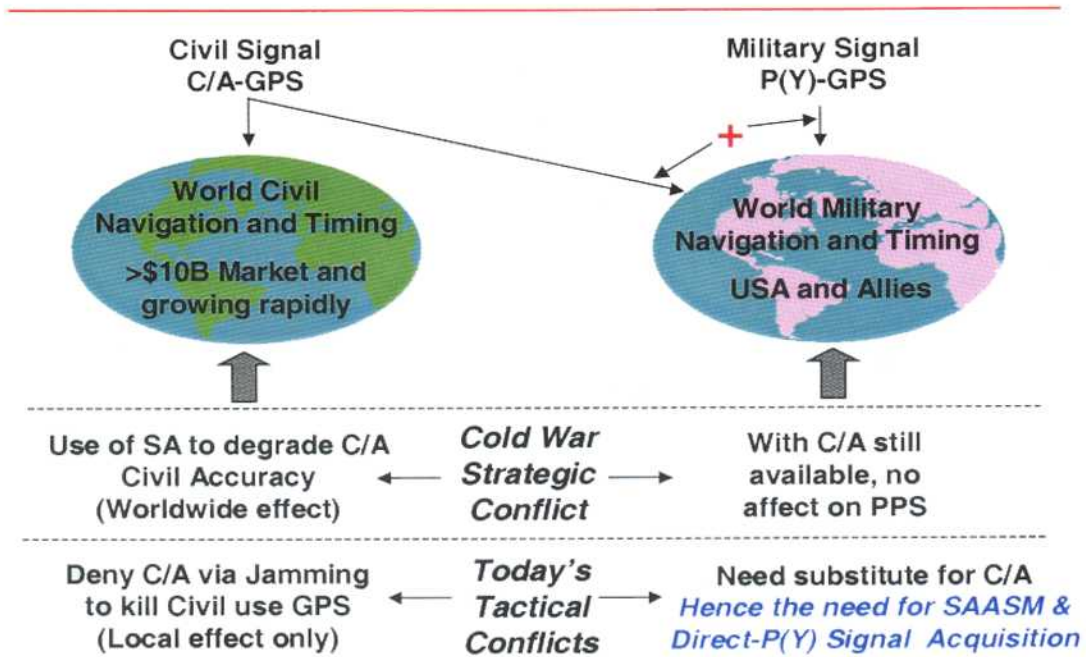

jamming work for the military? Simple—it requires the new generation military GPS receiver technology called “SAASM” with a unique capability to do “Direct-P(Y)-Code” signal acquisition. As stated before, “Direct” means that the receiver can acquire the military signal without the aid of the C/A-Code signal that gives it the needed time-tick. This is made possible by massive parallel signal processing and bit correlation to compensate for the lack of accurate time, as illustrated in Figure 2.

Figure-2, Direct P(Y) Signal Acquisition Correlator

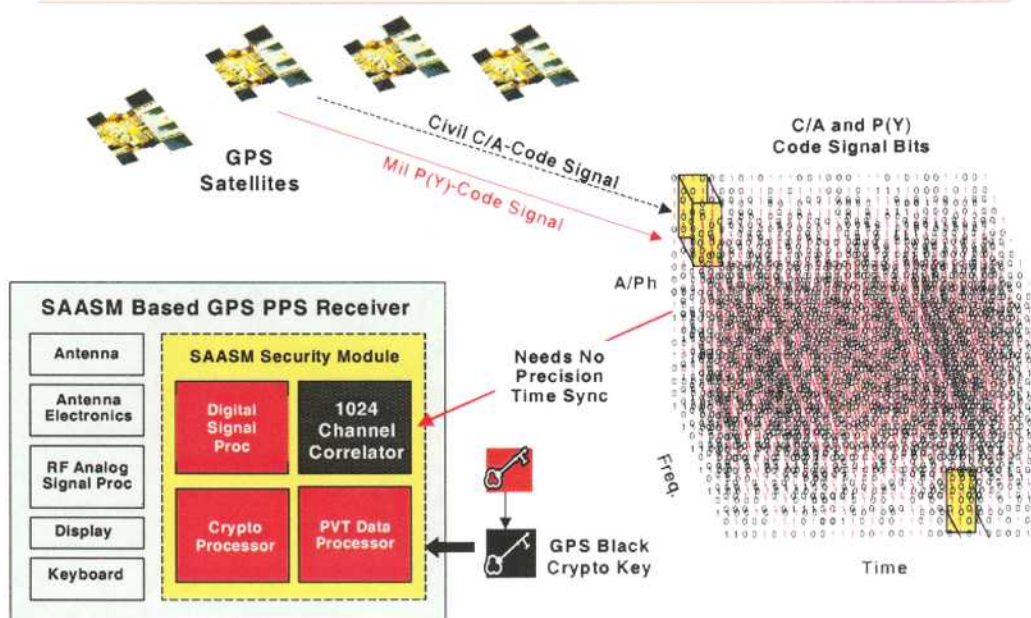

DIRECT-P(Y)-CODE SIGNAL ACQUISITION

This new capability, part of most SAASM receivers, is the glue that makes the military GPS operational scenarios concerning the civil C/A and military P(Y) signals hold together. How does the USA economy reap the benefits from a lucrative worldwide civil GPS market, while at the same time GPS is protecting our forces from adversaries using the civil signal during a conflict? The answer lies in the new GPS strategy emerging from our military planners. Until recently it was: “provide the ‘in-the-clear’ civil signal to all, but not at full capability, and during certain military operations, degrade the signal even more.” This accuracy degradation is carried out by using SA (Selective Availability), the intentional distortion of the civil C/A satellite signals.¹ During military conflicts, for example, the government may choose to set the civil navigation accuracy to 100s, even 1000s, of meters, rendering GPS useless to our adversaries using commercial receivers.

Last year (September 2000), the long-awaited removal of the distortion on the civil signal of about 100 meters and 1 microsecond was finally realized. The availability of this full-strength civil signal is the result of the new philosophy from our military planners: “provide full civil capability, even with future enhancements and augmentations, and surgically deny the civil C/A signal through local jamming in times of conflict.” The scope of this shift of thinking is actually quite profound. Previously, the military planners relied on SA to make the civil signal unusable in case of a conflict. Implementing SA, however,

¹ The navigation and timing accuracy provided by the civil signal can be set by the satellite controllers to any level desired. With no distortion, the navigation accuracy will yield about 10 meters CEP (Circular Error Probability). The corresponding UTC time accuracy is 100 nanoseconds or better most of the time. UTC-Universal Coordinated Time is derived by the GPS constellation by taking atomic time and adding the required leap seconds. For the past 20 years till recently, the civil signal was semi-distorted, giving the commercial world a signal a factor of about 10 worse than the full capability mentioned above.

is always universal and worldwide, since the satellites cannot selectively choose a specific geographic area for signal degradation. In the cold war days, this of course was a reasonable approach in terms of potential strategic conflicts. Now, with GPS integrated in almost every corner of our lives, SA changes are undesirable because they will be felt worldwide. On the other hand, the new local jamming scenario to deny the civil signal is very desirable because it affects only the targeted area. It also reflects the new political and military realities—tactical, localized warfare rather than strategic ones.

Local jamming instead of SA has its drawback, however—and this is where SAASM Direct-P(Y) signal acquisition comes in. It means that the authorized users must be equipped with SAASM receivers so that they stay online and the bad guys don't. Unknown to most, the conventional PPS receiver must have the civil signal available to obtain an accurate time-tick in order to acquire the military crypto P(Y) signal. With the conventional SA scenario, the civil signal is still present, distorted as it may be. With no civil signal, a SAASM receiver is the only practical option. The less desirable alternative is to have a precision clock in the user equipment to provide the time tick, atomic in nature, capable of time accuracies of several hundred nanoseconds. It is unlikely such would be available to most users. The SAASM receiver Direct-P(Y) signal acquisition process is illustrated by Figure 3.

Figure-3, The Direct P(Y) Signal Acquisition Process

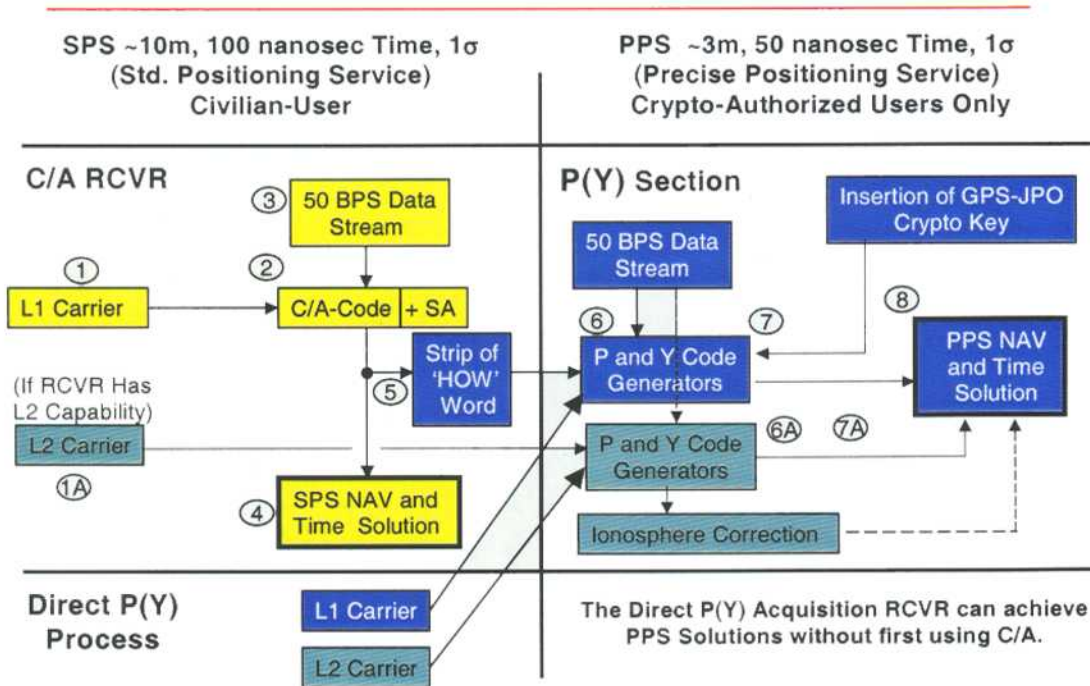

Direct acquisition of the military signal without a very accurate clock was not practical or even possible until recently. The advances in signal processing speed and micro-miniaturization now allow for massive parallel data processing and bit correlation to compensate for the lack of accurate time. As can be seen by Figure 4, 1024 or even 2048 correlator bins search for a code match, allowing for a less accurate clock to initialize the search. This compares to only one bin for the traditional C/A code search. Depending on

Figure-4, Massive Parallel Processing for Direct-P(Y) Signal Acquisition

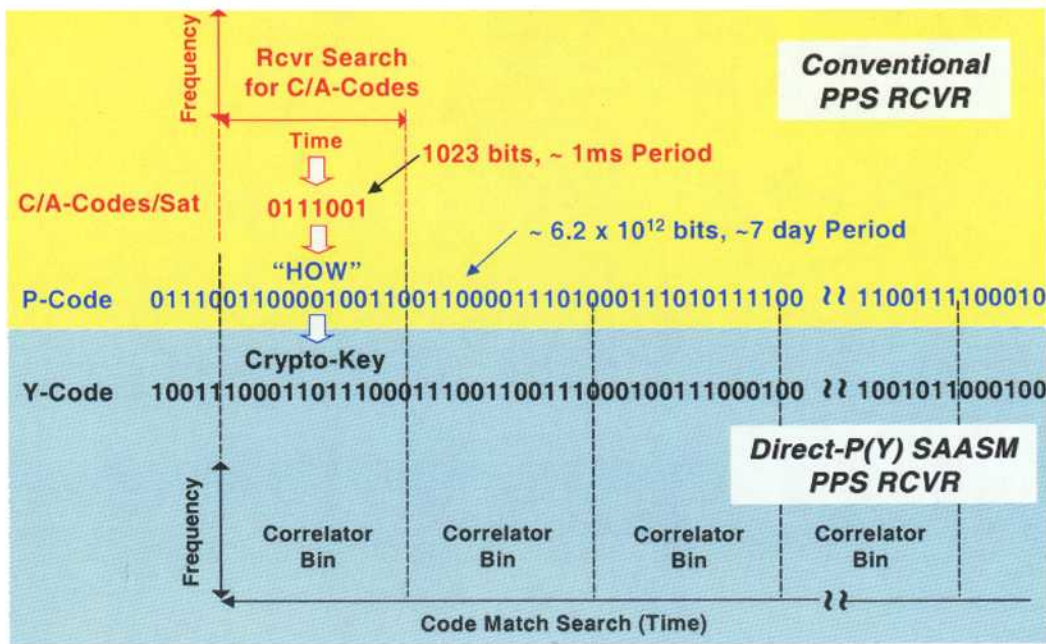

11-01

the receiver design, its UTC² time reference can be off as much as ± 1.5 seconds instead of the previous 100 or so nanoseconds, a factor of more than a million. The receiver’s signal acquisition time, generally referred to as the “time to first fix” (TTFF), is mainly a function of how well the initialization time reference is known and the signal jamming environment the receiver finds itself in. For example, a well-designed SAASM Direct-P(Y)-Code receiver with 1024 parallel correlator channels will come online within the time approximated in Figure 5, influenced by the jamming environment shown.

SAASM AND THE TELECOM TIME/FREQUENCY TERMINAL

In addition to a host of advantages for SAASM GPS navigation and weapons targeting, the time and frequency community benefits as well. Civil and P-Code equipped GPS time and frequency systems play a major role in both ground and space-based communications and command/control operations. There are essentially three categories of GPS-equipped telecom terminals today: (a) The conventional “C/A-only” SPS terminal. With the civil C/A signal jammed, the terminal goes on what is called “hold-over” using its internal oscillators and eventually goes down if the C/A signal is not restored. Unfortunately, this category is by far the most widely deployed terminal for commercial and agency applications. (b) The conventional military “C/A-P(Y)” PPS terminal. Here, the situation is improved somewhat. If the terminal is operating on the P(Y) signal at the time the C/A signal is jammed, the receiver will stay

² Throughout this paper, the reference to UTC time is done for convenience. There is actually a time difference between UTC (Universal Coordinated Time) and GPS satellite constellation atomic time. This is due to the fact that UTC is maintained using “Leap-Second” updates, whereas GPS time is purely atomic time, unencumbered by celestial happenings. The GPS system tracks leap seconds separately so the user can choose GPS time or UTC. In either case, it is not germane to the discussions in this paper.

Figure-5, Approximation of TFFF vs. Time Error

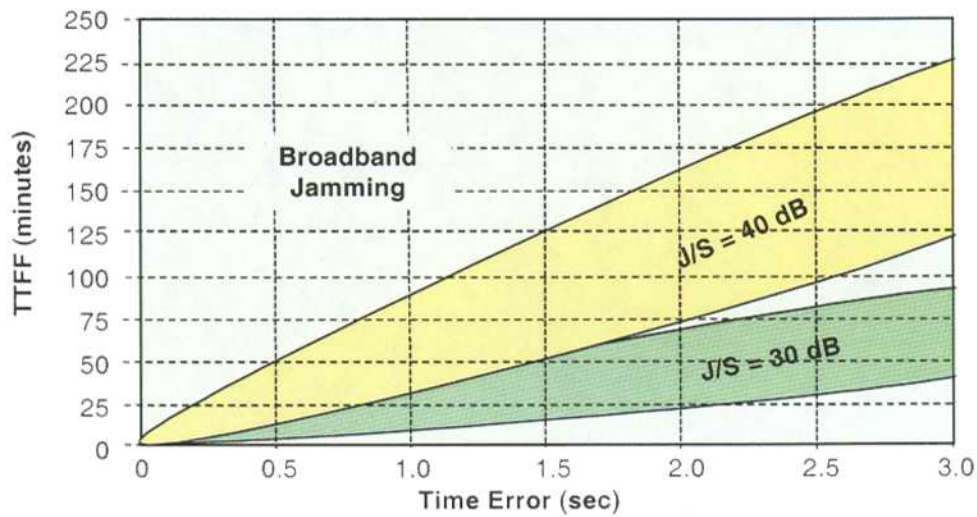

J/S ~ 25 dB from a BB Jammer, C/A acquisition difficult, may track up to 40 dB
 J/S ~ 40 dB from a BB Jammer is considered a moderate jamming level

11-01

online. However, if anything happens to this P(Y) signal or there is a power failure, the system cannot restart cold in the absence of C/A; that is, a communications or command and control link cannot be reestablished. (c) The new SAASM “Direct-P(Y)” PPS terminal. This is the optimum solution. Not only will it stay online when the C/A signal is jammed or not available for whatever reason, but it can also start cold without it. In the world of terrorism threats, it behooves the nation to implement SAASM terminals not only in the military and agency infrastructures, but also in the high-value commercial sector as well. SAASM goes a long way towards protecting the terminals against hostile jamming and spoofing.

There are actually two categories of Direct-P(Y) SAASM receivers: the weapons targeting receiver and the telecom, time and frequency receiver, as illustrated in Figure 6. The *weapons receiver* must have the capability to acquire the P(Y) signal very rapidly in the absence of C/A, because its host weapon may only have a flight-time of a minute or so. To facilitate this scenario, a Host-Platform GPS system provides a very accurate position as the projectile leaves the launch tube or barrel and an initialization clock in the 10s of microseconds. As a result of all the requirements and the Host-Platform support structure, the weapons receiver can deal with a time uncertainty in milliseconds and a position uncertainty as shown in Figure 6. Only several hundred parallel correlator channels are needed to satisfy these requirements. The *telecom time and frequency receiver*, on the other hand, generally needs not to acquire as rapidly as its weapons system counterpart. It will also not have the benefit of a Host-Platform GPS system—in other words, it has to be on its own. Since the acquisition time is generally not a driver, the initialization parameters can be loose, with uncertainty in seconds. As a result, this receiver is correlator-intensive, requiring at least 1000 channels to handle the relatively large time uncertainty.

Figure-6, Direct-P(Y) Receiver Applications
 (No C/A available to provide the ~100ns clock for std. P(Y) acq.)

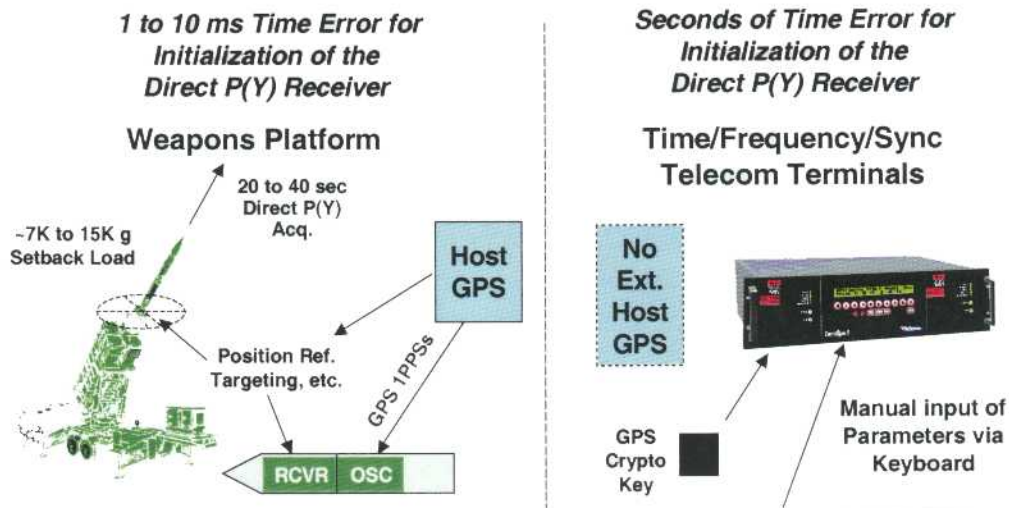

Typical Initialization Parameters needed for Direct P(Y) Acquisition

Position Uncert.	a few meters SEP	< 100 Km Radius
Velocity Uncert.	N/A	< 100 Km/h
Time Uncert.	± 10s of microseconds	± 1.5 seconds

11-01

INITIALIZATION PARAMETERS FOR THE SAASM TELECOM TERMINAL

The Direct-P(Y) SAASM-equipped telecom and time/frequency terminal needs several parameters to be initialized to facilitate P(Y) acquisition in the absence of the C/A signal. As shown in Figure 5, the TTFF is mainly a function of the size of the P(Y)-code signal bit field to be searched, which in turn is a function of how accurately the initialization parameters can be specified, especially time.

POSITION

The terminal's position should be known to within a 100 km radius, easily determined from a map of the area. The longitude and latitude is then transferred to the terminal via the keypad as shown in item (1) of Figure 7. Again, the more accurately the position is known, the less time it takes for the TTFF.

VELOCITY

Contrary to a weapons/projectile application, the Telecom Terminal is assumed to be stationary or at most moving 100 km/hour. Moving much faster than this will make Direct-P(Y) difficult. No keyboard inputs are required for this parameter.

TIME

A robust Direct-P(Y) SAASM receiver for telecom applications can handle an initialization time uncertainty of as much as ± 1 to 2 seconds. This is designed specifically to allow wristwatch initialization. Jamming and initialization time accuracy are the major contributors for TTFF (Figure 5).

Figure-7, Manual Interactions with a SAASM Equipped Telecom Terminal

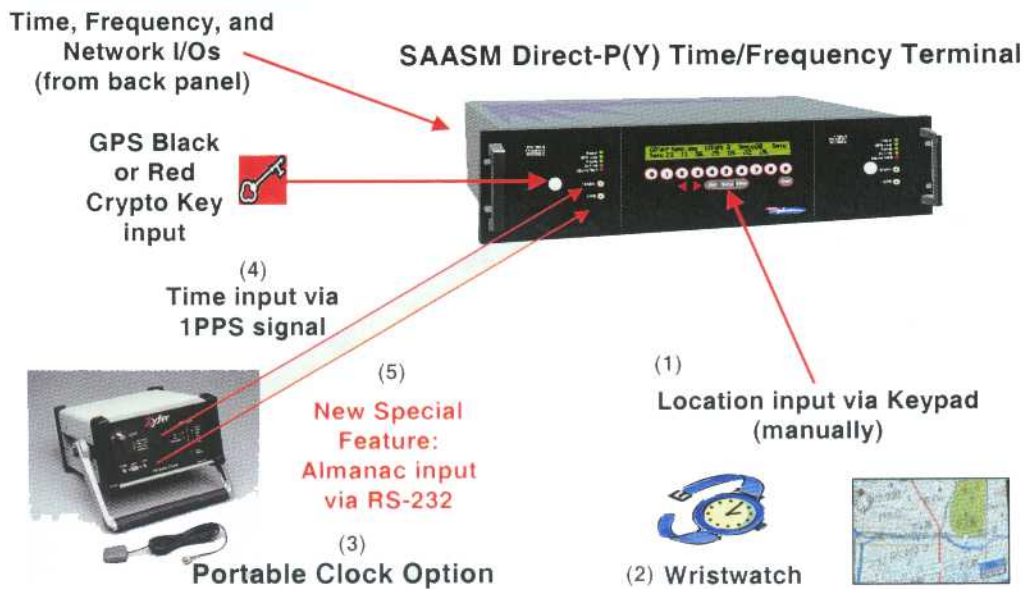

11-01

As with position data, the wristwatch time is transferred to the terminal using the keypad as shown in item (2) of Figure 7. An alternate way to transfer time is via a Special Portable Clock, as shown in item (3), details of which will be described in the next section.

THE ALMANAC

This parameter has not been mentioned thus far but is an important element in the initialization process. The Almanac³ that the receiver has loaded in its memory should not be older than a week. Since C/A is not available and the receiver is making a cold start, the ephemerides of the satellites it is attempting to acquire is not known to the receiver. As a result, it uses its stored library (the Almanac) to determine satellite positions. Since the GPS constellation is relatively stable, a week-old Almanac should do the job, but a younger data set will be better and speed up the TTFF process. For the wristwatch initialization, the receiver will use the latest Almanac in its memory; the one loaded during the last time

³ The Almanac is a library of satellite information, pertinent to signal acquisition and subsequent positioning and timing accuracy. From it, it can be estimated when and where satellites will appear over the horizon, including an estimate of relevant satellite ephemerides (positions) and a host of other parameters needed for the receiver to figure out where it is. Once position is accurately known, the receiver will determine accurate UTC time.

the receiver was online. Using a Portable Clock for initialization brings the added advantage of the latest Almanac it has in its memory. Its dataset will most likely be only a day or so old, again, as recent as the last time the Portable Clock was in the standby mode receiving the C/A signal. Therefore, the Portable Clock loads accurate time via 1 PPS (Item #4 of Figure 7) and the Almanac via RS232 (Item #5).

THE SPECIAL PORTABLE CLOCK

For the Terminal activator and operator in a hurry, a special Portable Clock will certainly come in handy—a clock that can hold UTC time accuracy to within 1 millisecond in a 24-hour period. As can be seen in Figure 5, with time errors in the millisecond range, Direct-P(Y) acquisition is virtually instantaneous. With time errors in the seconds range, TTFF may take dozens of minutes, even an hour or more, depending on jamming levels. The Portable Clock, therefore, is an indispensable crew safety tool, in that a terminal being erected in hostile territory will cold-start instantly, even in a heavy jamming environment and with no civil C/A signal present. In order for the receiver to come online quickly, the Portable Clock also loads the most recent GPS Almanac. If the Direct-P(Y) receiver's Almanac data are more recent, it will reject the input from the Portable Clock.

To put things in perspective, for the purpose of this paper, "Special Portable Clock" is defined as a low-cost unit that can easily be carried; 20 pounds or less, with a precision quartz-crystal oscillator as the source for frequency and time generation. This is in contrast to the original cesium-beam (Cs) Portable Clocks that existed in years past, weighing over 100 pounds and cost in excess of \$40,000 dollars. Although highly accurate for several hours after calibration, the sheer mass and volume of these original Cs units made them impractical for field operations then, and certainly for today as well. Also, the time accuracy requirements for a Portable Clock serving SAASM Direct-P(Y) applications is less stringent than what was needed for time transfer in days past. Earlier clocks attempted to achieve nanosecond to microsecond accuracy levels, where SAASM requires only milliseconds for fast acquisition.

For this reason, a Portable Clock specifically designed to meet SAASM requirements should keep UTC time uncertainty to within milliseconds at the end of 24 hours, including road-travel environments and temperature swings from 0 to 40 degrees C. This accuracy can be achieved with a well-designed GPS-disciplined circuit and holdover algorithm, working in conjunction with a precision quartz crystal oscillator. When powered by AC with the C/A signal present, the portable clock assumes it is in a stationary mode, enabling its internal GPS C/A receiver to steer its internal oscillator to remain within 100 nanoseconds of UTC time. When powered by 12 VDC, it assumes it is in a moving mode and disables the C/A signal even if present. This is because the moving mode may not discipline the internal oscillator correctly and the clock will most likely keep better time from just its free-running oscillator. When all external power is removed, the clock goes into the portable mode, powering down the GPS receiver plus all non-essential circuitry and uses its internal batteries to power the clock. The oscillator stability, coupled with the holdover algorithm (which memorized the oscillator's internal aging and response to temperature changes while it still had C/A), holds accurate time, slowly drifting from its 100-nanosecond starting point to the specification value over the 24-hour period. As discussed previously, the most recent Almanac received while the Portable Clock's GPS receiver was still locked to the satellites is placed in memory, available for transfer to its host Direct-P(Y) receiver. A typical Portable Clock should have the following functionality, as shown in Figure 8.

THE SAASM MANDATE

As detailed earlier, the new civil and military GPS user relationships require the fielding of SAASM Direct-P(Y)-Code GPS equipment. In 1998 the Chairman of the Joint Chiefs of Staff (CJCS) issued a SAASM deployment mandate. The mandate has not changed since then, with waivers granted only on a case-by-case basis. The “quote” of the actual mandate is shown in Figure 9.

Also, security regulations have been revised for builders of Host Applications Equipment (HAE), meaning hardware that implement SAASM PPS receivers in weapons and Telecom Terminals. Makers of such equipment must first have a government security infrastructure and, additionally, must go through rigorous design reviews of their HAE architecture. Authorized SAASM receiver and HAE developers are listed on the GPS Joint Program Office (JPO) Web site <http://gps.losangeles.af.mil>.

The SAASM receiver and its Direct-P(Y)-Code capability will prove to be a powerful tool in the hands of our military and authorized users. What C/A has done for the GPS boom in civil community, SAASM will do for the authorized community—authorized meaning the US military, governmental agencies, our allies, and other categories of commercial authorized users. To enhance the Direct-P(Y) functionality, the Portable Clock will find a new niche in the military and governmental applications of SAASM.

Figure-8, The Portable Clock



- Autonomous - Cold Start to 100 ns UTC Time Accuracy - with GPS-C/A
- Continuous Update to 100 ns UTC Time while in Standby with GPS-C/A
- $1E-11$ Frequency Accuracy of 10 MHz Output while in Standby with GPS-C/A
- 120/240 VAC and 12 VDC Vehicle Power Option for Standby Power
- 24 hour Battery Life in Portable Mode
- 1 ms UTC Time Accuracy after 24 hours in Portable Mode
- $1E-10$ (typical) Freq. Accuracy of 10 MHz Output after 24 hours in Port. Mode
- Time Transfer to Host via Coax Cable Carrying a 1PPS signal
- GPS Almanac Transfer to Host and PC I/O with Portable Clock via RS-232
- 0 to 40C Temp Range; <20 lbs.

Figure-9, The SAASM Mandate

“.....

Per CJCSI 6140.01 (Original release OCT. 22, 1998)

- SAASM is the next generation GPS security
- After JAN.1, 1999 - Procure SAASM only for all new handheld applications; (Red & Black Keys allowed)
- After JAN. 1, 2000 - Procure SAASM only for all new user equipment; (Red & Black Keys - allowed)
- After OCT. 1, 2002 - Procure SAASM only, use Black Keys only, cease fielding non-SAASM equipment

.....”