

# A NEW CLASS OF PRECISION UTC AND FREQUENCY REFERENCE USING IS-95 CDMA BASE STATION TRANSMISSIONS

Bruce M. Penrod  
EndRun Technologies

## Abstract

*This paper introduces a new class of precision timing and frequency reference that indirectly receives GPS timing and frequency information via the transmissions from Code Division Multiple Access (CDMA) mobile telecommunications base stations operating in compliance with Telecommunications Industry Association (TIA/EIA) Standard IS-95. Like cell phones, these products operate indoors without external antennas and provide unprecedented value to a large class of users in terms of accuracy, cost, and ease of installation. The technology fits particularly well in IP network synchronization and quality-of-service monitoring applications where rooftop antenna installation is often impossible.*

*EndRun Technologies has developed and is manufacturing a proprietary time and frequency engine specifically optimized to faithfully reproduce the inherent precision time and frequency characteristics of the IS-95 CDMA spread-spectrum signals. The Præcis family of time and frequency products uses this engine, and hundreds of these units have been deployed throughout North America since October of 2000. The salient characteristics of the IS-95 CDMA signals which make it so well suited to this use and a general receiver architecture are described. Performance data versus similar references that use conventional GPS reception are also presented.*

## INTRODUCTION

Last year, products based on a new way of obtaining precision and UTC traceable time and frequency were on display in the exhibit area of the PTTI 2000 meeting. Though the exhibit area was deeply buried within the hotel in a windowless room, these new products were receiving GPS-derived, precision UTC traceable time and frequency using cell phone antennas. Since there were no GPS re-radiation antennas in place in the exhibit area last year, it is likely that these were the only products there that were providing UTC at the 10-microsecond-level of accuracy.

*Indirect GPS* is arguably the best description for this new technology that has been made possible by the rapidly expanding, global deployment of IS-95-compliant mobile telecommunications systems. Since IS-95 system time is by definition equal to GPS time [1], base stations operating in these systems act as *repeaters* of the GPS timing information they receive from the satellites in order to synchronize themselves. The spread-spectrum modulation scheme employed in IS-95 systems has striking similarities to that of the GPS, allowing the underlying GPS time reference to be extracted from the base station transmissions with a high degree of precision using a small, low-cost, passive receiver with integrated cell-phone antenna. This new approach eliminates the cost and hassle of installing a rooftop antenna for users that are within range of one of these base stations.

## WHY IS-95 SYSTEMS ARE SYNCHRONIZED TO GPS TIME

Like the GPS, IS-95 is a spread-spectrum system that uses CDMA techniques to differentiate multiple, simultaneous users of the same frequency channel. In the GPS, all of the satellites transmit on the same frequency. Each satellite uses a different pseudonoise (PN) *spreading* code to distinguish its transmissions from those of the other satellites which are all transmitting simultaneously. In the IS-95 system, all base stations transmit on the same frequency. They also transmit the same PN spreading code. So how does this work?

Although each base station transmits the same spreading code, each transmits it with a different time delay offset relative to the on-time, or zero-offset, spreading code. Since the base stations are not moving and the range of their coverage is intentionally very short, this relative offset can be made large enough that a mobile unit could never be close enough to one base station, and far enough from another, that the codes received from the two base stations would line up and interfere with each other. In a cellular mobile phone system, the typical light speed propagation delay from a base station to the edge of its coverage cell is about 10 microseconds. For this reason, in an IS-95 system base stations transmit with PN code offsets which are multiples of about 50 microseconds. This allows base stations to have a timekeeping error budget on the order of 10 microseconds and still maintain adequate separation between the PN codes in neighboring cells.

It should be evident that each base station must have a way of knowing when to begin transmitting its replica of the PN code relative to all of the other base stations in the system. There really is only one globally available option for maintaining this level of synchronization. For this reason, the IS-95 standard defines CDMA system time to be the same as GPS time and requires that base stations be synchronized to GPS time to less than 10 microseconds, even during periods of GPS satellite unavailability lasting up to 8 hours [2].

IS-95 systems take advantage of this inherent level of synchronization to implement an efficient, *soft hand-off* call-transfer strategy as the mobile user moves through the cells. This feature is based on the ability of the mobile handset to calculate the correlator offset to the neighboring base stations with sufficient accuracy to allow a much abbreviated search when changing over. This results in many fewer *dropped* calls. It turns out that dropped call statistics kept for each base station provide a key indicator of timing impairments in the CDMA system [3].

## HOW IS-95 SYSTEMS ARE SYNCHRONIZED TO GPS TIME

The timing and frequency signals transmitted by the typical IS-95 base station are sourced from a better GPS timing receiver than most end users of GPS timing could justify for their application. The high quality and reliability of these time and frequency standards provides much of the motivation for the development of the indirect GPS timing technology which is the subject of this paper. Why are receivers of this quality needed?

Since it cannot be assumed that the typical base station will have a climate control system, the GPS timing receiver (many sites have redundancy) at each base station in an IS-95 system is equipped with either a rubidium vapor local oscillator or an ultra-stable, ovenized quartz local oscillator with software temperature compensation. Such elaborate means are needed to ensure that the base station will maintain the required timing accuracy during GPS signal outages. During such outages, the base station timing must *fly-wheel* on the free-running stability of the local oscillator.

## IS-95 SYSTEM OVERVIEW

Figure 1 depicts the general architecture of an IS-95 CDMA network [4]. One or more transceiver sites (base stations) are connected via dedicated wire lines to a Mobile Telephone Switching Office (MTSO). The MTSO is responsible for coordinating the base stations that are connected to it and interfacing their voice and data traffic to the Public Switched Telephone Network (PSTN). In a CDMA system, the MTSO is also responsible for maintaining system time and monitoring the timing status of its connected base stations. This function requires the co-location of at least one GPS time and frequency reference receiver. Each base station must also independently maintain system time and frequency, so a co-located GPS time and frequency receiver is required at those locations as well.

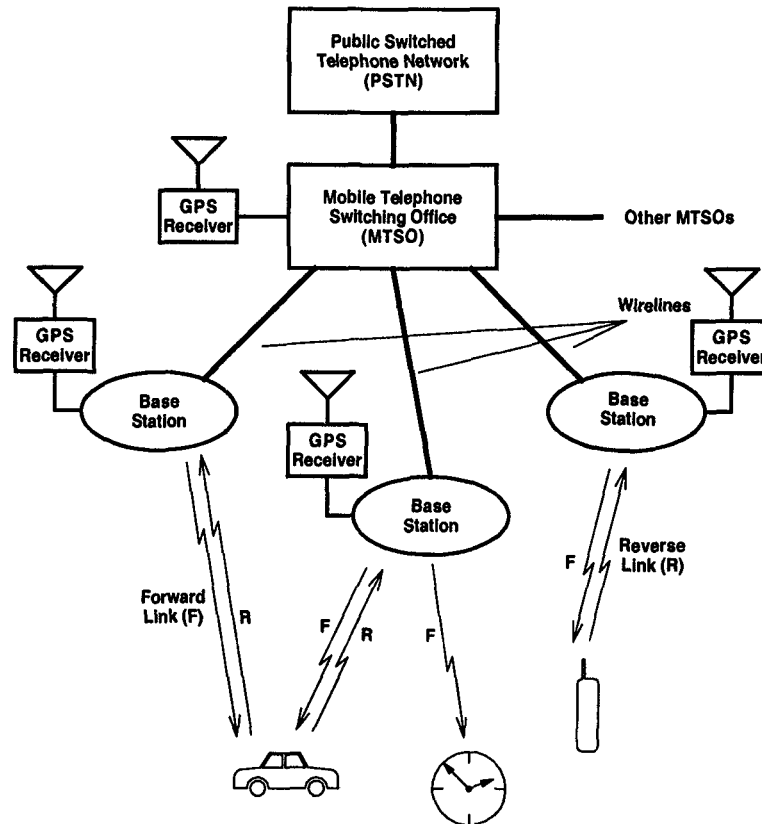

Figure 1 – CDMA Mobile Telecommunications System

There are two types of IS-95 CDMA systems operating today. They are distinguished by the carrier frequency bands in which they operate. The original analog cellular mobile telecommunications system, also known as the Advanced Mobile Phone System (AMPS), occupies the 800 to 900 MHz band which has become known as the *cellular* band. In North America the largest CDMA provider using the AMPS cellular band is Verizon Wireless [5]. In more recent years, demand for spectrum has opened up a band in the 1900 MHz region for cellular mobile telecommunications use. This band is known as the Personal Communications Systems (PCS) band. U. S. Sprint is the largest CDMA provider using the PCS band in North America. In other parts of the world, CDMA providers operate in the same two general regions of the spectrum. However, the specific carrier frequency bands used within those regions are in general not the same as those used in North America.

Cellular systems offer better performance in terms of range and building penetration [4]. For the purpose of transferring time and frequency to stationary users inside of buildings or at the fringes of a coverage area, this is a definite advantage. Due to the more rapid signal attenuation at the PCS carrier frequency, PCS offers the ability to space the coverage cells more densely in heavily populated urban environments and thereby handle more traffic. For the passive transfer of time and frequency, this offers no advantage. The implication is that the preferred system for time and frequency transfer using IS-95 CDMA uses the cellular frequency band. Unfortunately, there are locations having PCS coverage only. In these areas a PCS time and frequency receiver is the only option and performance inside buildings is less predictable.

In a mobile telecommunications system, transmissions from the base station to the mobile user are on the *forward link*. Transmissions from the mobile user to the base station are on the *reverse link*. Like GPS, time and frequency transfer via the IS-95 CDMA technology is passive, or receive-only. The needed precise time and frequency information is contained in the transmissions on the forward link and it is not necessary to handshake with, or be a subscriber to, the mobile telecommunication system in order to just *listen* to the transmissions. Consequently, the reverse link will not be discussed in great detail here.

## FORWARD LINK STRUCTURE

Mobile telephones when first energized must receive and decode the system timing information on the forward link in order to be able to initiate or receive calls. The forward link is composed of multiple channels which are active simultaneously. Channel multiplexing is by a set of orthogonal *covering codes* that bi-phase modulate the data stream in each channel ahead of the PN code spreading modulation. These covering codes are chosen from a set of order 64 Walsh functions, which means that there are 64 of these functions, each containing a different pattern that is 64 chips long. The channels consist of the pilot channel, the sync channel, up to 7 paging channels, and up to 55 traffic channels.

Rejection of narrowband signal interference as well as neighboring base station interference is via direct-sequence, PN code bi-phase modulation. The Walsh-covered channel data are spread with two different PN codes designated I and Q. The resulting pair of bit streams are used to modulate the I (cosine) and Q (sine) radio frequency (RF) carriers to generate a form of quaternary phase-shift keying (QPSK). The PN codes are  $2^{15}$  chips long, and the chipping rate is 1.2288 megachips per second (Mcps). The code therefore repeats every 26.666... milliseconds. Isolation between adjacent base stations is accomplished by assigning each base station a PN code offset that is a multiple of 64 chips of the PN code. These offsets equate to PN code broadcast delays that are multiples of 52.0833... microseconds. There are 512 such offsets covering the full length of the PN code.

For the purposes of time and frequency transfer, only two of the channels must be demodulated. Figure 2 shows the details of the generation of the pilot and sync channels at the base station. The pilot channel is broadcast at the highest power level of the forward link channels. It is unique in that its data are all zeros. Since the pilot data are a constant zero, the initial PN correlation search in the receiver is simplified because the integration time may be made as long as is needed to bring the signal up out of the noise. After pilot phase lock has been accomplished, it provides the reference phase for the coherent demodulation of the remaining data-carrying channels.

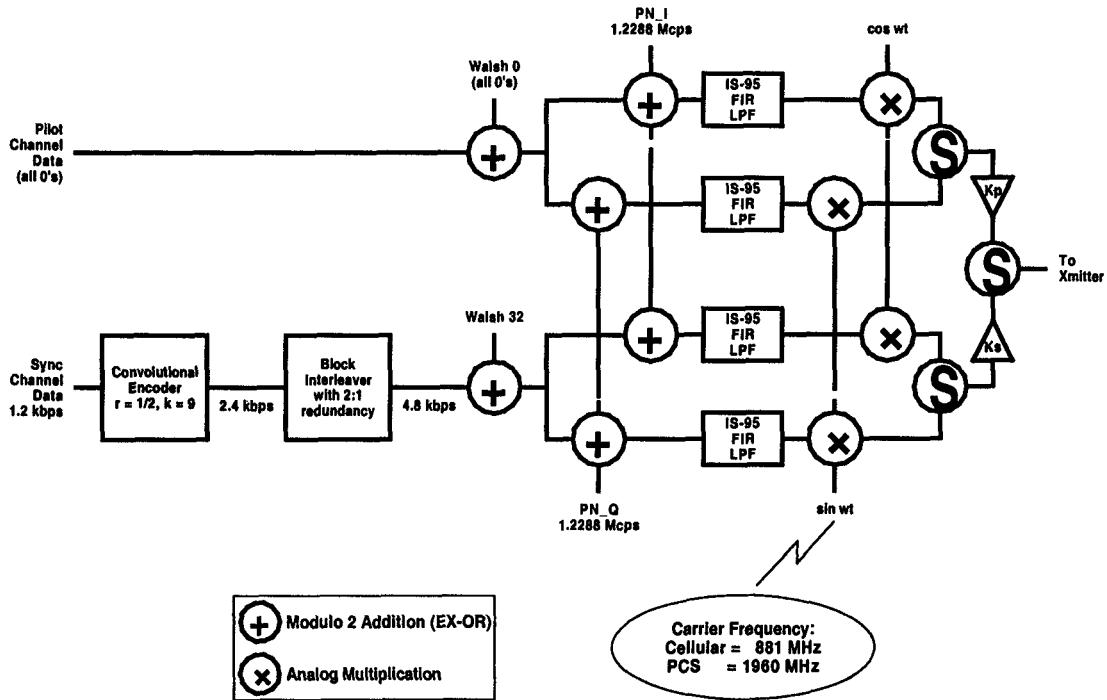

Figure 2 – Pilot and Sync Channel Signal Structure

The sync channel is broadcast at a level approximately 9 dB below that of the pilot channel. The data contained in the sync channel broadcast is a fixed-length *message* that enables the mobile receiver to establish GPS, UTC, and local time. In order to access the paging and traffic channels, mobile phones need the current state of the *long PN code* which is also contained in the message. The long PN code is not used for the purpose of time and frequency transfer and is mentioned here for completeness and because its use has an interesting resemblance to that of the GPS P-code. The long PN code is  $2^{42}$  bits long and repeats every 41 days. It is used in the forward link to scramble paging and traffic data sent from the base station to the mobile unit. On the reverse link, each mobile unit uses a non-overlapping piece of the long PN code, assigned to it by the base station, to distinguish its transmissions to the base station from those from other mobile units.

Sync channel data are sent at 1200 bits per second (bps). Prior to transmission it is convolutionally encoded using a rate  $\frac{1}{2}$ , constraint length 9 encoder. This effectively creates two *symbols* for each bit of data and allows error correction at the receiver. Each symbol is then repeated once, and a *block* of 128 of these is then *interleaved*, which means to re-order (scatter) them within the block to provide temporal diversity. This is a means of mitigating burst errors to improve error correction when the symbols are decoded at the receiver. This block of symbols is then transmitted at 4800 bps as a *frame* with each frame being aligned with, and having the duration of, one repetition of the PN code. Three contiguous frames compose a *superframe*. The entire sync channel message, including the 30-bit cyclic redundancy code (CRC), occupies less than three superframes, so it is zero-padded to fill them completely. The time-of-day information contained in the message is valid four superframes after the end of the last superframe containing the message. Since each base station transmits its PN code with an offset delay relative to the zero offset PN code, the PN code offset of the specific base station is also contained in the sync channel message so that this fixed delay can be corrected.

The resulting pilot and sync channel 1.2288 Mcps I and Q streams are sampled and digitally lowpass filtered to satisfy the IS-95 bandwidth requirement. Finally, they are converted back to analog waveforms to modulate the cosine and sine RF carriers. The amplitudes of these signals are adjusted prior to transmission to provide the appropriate power levels relative to the other channels.

The various waveforms that compose the transmitted forward-link signal are coherent with the co-located GPS time and frequency reference. The PN codes, Walsh functions and superframes all began synchronously with second 0 of GPS time. The PN codes and Walsh functions are again aligned with every even GPS second thereafter, the superframes every third even second [1]. During normal operation, this even second alignment to GPS time is at the 1 microsecond level [2]. Although the IS-95 standard does not require that base station RF carrier frequencies be controlled to better than  $5 \times 10^{-8}$  [2], in practice they are precisely phase-locked to the GPS frequency reference as well.

## IS-95 CDMA SIGNAL RECEPTION

Figure 3 depicts the general architecture of a receiver specifically designed to demodulate and recover the underlying precision time and frequency signals present in the forward link transmissions of an IS-95 CDMA network.

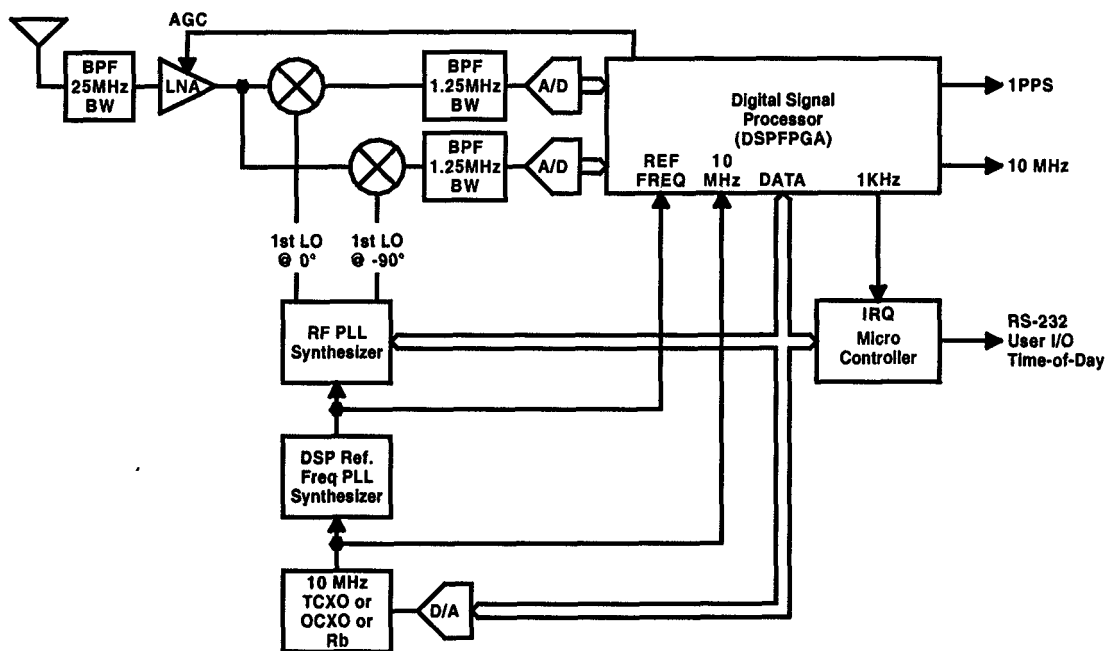

Figure 3 – CDMA Time and Frequency Receiver

## FRONT END

The desired signal band is pre-selected using a surface acoustic wave (SAW) filter appropriate for the particular system. In the North American AMPS cellular band, forward-link transmissions are contained in the range of 869 – 894 MHz. Those for the PCS band are contained in the range of 1930 – 1990 MHz.

Following pre-selection filtering, the signal is amplified. An automatic gain control capability is needed due to the wide dynamic range of the received signals. The signal is then downconverted in quadrature to a low intermediate frequency (IF) suitable for digitizing with high-speed analog-to-digital converters. Quadrature downconversion is necessary to demodulate the complex CDMA signal structure. Prior to digitizing, the I and Q signals are bandpass filtered to match the IS-95 bandwidth of 1.25 MHz.

## **FREQUENCY PLAN**

The receiver is designed to operate using a 10 MHz reference oscillator. The signals required for IS-95 demodulation are synthesized from this reference in two stages. Since the clocking frequencies needed for the digital signal processing (DSP) of the IS-95 signal are not obtainable via direct division of the 10 MHz reference frequency, a DSP reference frequency is synthesized using a separate crystal oscillator inside of a phase-locked loop (PLL). This DSP reference oscillator frequency is divided as needed in the DSP field-programmable gate array (DSPFPGA) to perform the final downconversion and baseband processing. The DSP reference oscillator also provides the reference for the RF PLL synthesizer that generates the 1<sup>st</sup> local oscillator (LO) signal for the initial quadrature downconversion.

## **DIGITAL SIGNAL PROCESSING**

The DSPFPGA performs the high-speed multiply-and-accumulate (MAC) arithmetic for the final conversion to baseband of the digitized I and Q signals. It synthesizes I and Q replica waveforms by modulo-2 additions of the various divisions of the DSP reference frequency and generates the I and Q PN codes via linear feedback shift registers (LFSR). The I and Q PN codes then spread the replica waveforms, which are then multiplied with the received signal and accumulated for some integer number of symbol intervals. These accumulations are then passed to the microcontroller for interpretation.

The high-performance microcontroller receives the raw baseband data from the DSPFPGA and controls the stepping of the phase of the DSPFPGA correlators to implement the pilot channel PN code search. After pilot detection, the early-late correlator powers are used to phase-step the correlator so as to maintain PN code phase lock. While PN code locking, the I and Q correlator sums are used to phase adjust the DSPFPGA-generated 2<sup>nd</sup> LO so as to align it with the pilot carrier phase. These code- and carrier-phase corrections are used to implement an outer PLL using the digital-to-analog converter to phase lock the 10 MHz reference oscillator to the received signal. This approach optimizes the short-term stability of the time and frequency outputs of the receiver by taking advantage of the higher resolution and lower noise characteristics of the carrier-phase measurements to smooth the code-phase measurements.

## **SYNC CHANNEL DATA DECODE AND TIMEKEEPING**

Once pilot code and carrier-phase lock has been attained, the sync channel correlator sums contain symbol data. The microcontroller *de-interleaves* these and processes them using a Viterbi decoder to recover the transmitted sync channel data. Real time is maintained in the microcontroller from the DSPFPGA-generated 1 kHz interrupt that is coherent with the 10 MHz reference oscillator. The location of the superframe boundaries relative to the 1 kHz interrupt is measured in the DSPFPGA. After successful data decode, as validated by the CRC, the microcontroller commands the DSPFPGA to synchronize the 1 kHz interrupt to the appropriate superframe boundary, advanced by the decoded base station PN offset. During the millisecond prior to the next second, the DSPFPGA is commanded to output the 1PPS synchronous with the next millisecond. After the initial synchronization of the 1PPS, all phase alignment is maintained via frequency control of the 10 MHz oscillator, so that the outputs have very low phase jitter.

## **PERFORMANCE CHARACTERISTICS**

Spread spectrum systems are ideal for high precision time transfer, so the performance of the described CDMA receiver in terms of its precision and short-term stability is very similar to that of a well designed GPS receiver. Since the CDMA time scale is in fact phase-locked to the GPS time scale, the long-term frequency accuracy and stability of the technology is essentially equal to that of GPS. Its limitations are in its absolute time accuracy and medium-term frequency stability. The limitations are due to several factors which are discussed in decreasing order of magnitude.

### **PROPAGATION DELAY**

The system is not intended to be a navigation system, and although the coordinates of the base station are contained in a paging channel message (so that a mobile phone can determine its nearest neighbors for handoff purposes), the ability to receive multiple base stations with adequate geometry to determine absolute position cannot be guaranteed. It must, therefore, be assumed that it is not possible to autonomously calculate the propagation delay from the base station for the purposes of improving the absolute accuracy of the time transfer.

Depending upon the density of the cells in an area, which is generally a function of the expected number of simultaneous users and/or the density of signal-obstructing buildings, the time-transfer uncertainty due to propagation delay ranges from less than 5 microseconds (urban, dense) to as much as 25 microseconds (suburban, sparse). Since it is always present and has the largest potential variation, this is the dominant factor in limiting the absolute time accuracy. Since both the base station and the receiver are stationary, it has no effect on the stability or absolute accuracy of the frequency that is transferred.

### **IS-95 TIMING SYSTEM REQUIREMENTS**

The system is also not intended to disseminate time to a level of accuracy beyond the stated requirements of the IS-95 standard, or 10 microseconds. Though the equipment that is being used to maintain that level of accuracy is normally much better than that [2], service providers have no responsibility or motivation to ensure any higher level of accuracy continuously. Although an alarm is generated immediately when a base station GPS receiver is operating in flywheel mode, it does not necessarily cause the base station to be turned off, and the system does not provide an indication of the GPS timing status in the forward-link data.

A visit to the base station by a technician might not occur until the base station experiences a statistically significant upturn in its dropped calls [3]. Service providers are motivated to maintain an acceptable level of service, and dropped calls represent loss of revenue. The 10-microsecond timing sub-system error budget allows flywheel operation to continue without interruption of service while the severity of the problem is being evaluated.

What this means to time and frequency dissemination over the IS-95 airwaves is that a very small, but not negligible, probability exists that the time being transferred is from a high-stability oscillator that has been free-running for some fraction of a day. This is the dominant factor limiting the medium-term stability of the realized time and frequency transfer.



## BASE STATION SWITCHING

From time to time, base stations are taken down for various reasons. When this occurs, the signals from neighboring base stations become receivable and the receiver will begin to track the strongest one of those. Due to the change in propagation delay from the new base station, this switchover can cause a step transition in the timing output. Depending upon the drift rate of the local oscillator in the CDMA receiver, a transient in the frequency output can occur while it is being brought back on frequency.

An algorithmic enhancement to the CDMA receiver can minimize the phase transient by maintaining a table of relative offsets between the receivable base stations in the area. In addition, the error in time transfer due to propagation delay can be held to that of the closest base station. The frequency transient can be controlled by using higher stability local oscillators, just as is done in conventional direct GPS receivers.

## MULTIPATH

Due to its specific utility as an indoor antenna alternative to rooftop antenna direct GPS, multipath effects are significantly greater than they are with rooftop-mounted GPS antennas that have clear visibility to the horizon. Rearrangement of the furniture or relatively small movements of the antenna can, by altering the strength of the direct signal relative to a long-delayed reflection, cause larger timing variations than might be expected. In *urban canyon* installations of direct GPS, where only one or two satellites may be visible and there are multiple signal paths due to reflections off of taller adjacent buildings, similar instabilities are seen as the satellites move across the sky.

Due to the correlation properties of the CDMA PN codes, timing shifts due to variations in the multipath reflections inside of a building are bounded by the width of a PN code chip to about 800 nanoseconds. Since direct GPS PN code chips are 25% wider, the timing shifts due to multipath are bounded to about 1 microsecond. In most situations, multipath-induced instabilities are secondary in magnitude to those that could arise from GPS flywheeling intervals at the local base station, but multipath phenomena will be experienced more often and by more users.

## PERFORMANCE DATA

Figures 4-6 represent data gathered during 14-24 November 2001 at the EndRun Technologies facility in downtown Santa Rosa, CA. The reference for these time-interval measurement data was a high performance GPS timing receiver disciplining a rubidium local oscillator with rooftop-mounted antenna, tracking a full constellation of satellites. The phase residuals of the digital phase-lock loop controlling the rubidium oscillator were continuously monitored during the data logging. Figure 4 shows the residuals plotted along with the ambient temperature. With SA being off, the phase error was maintained at less than 10 nanoseconds, with the measurements exhibiting a peak time deviation (TDEV) of less than 3 nanoseconds.

The cellular band CDMA receiver was equipped with a miniature, dual-inline packaged (DIP) oven-controlled crystal oscillator (OCXO) mounted directly on the receiver printed circuit board. This OCXO exhibits a temperature stability of about  $2 \times 10^{-9}/^{\circ}\text{C}$  and a short-term stability of about  $2 \times 10^{-10}$  at 1 second. The antenna was a  $\frac{1}{4}$  wave monopole with magnetic base attached upside-down to the metal framework that supports the acoustic tiles in the suspended ceiling. This is a recommended configuration, as it places the antenna above most obstructions inside of a typical room and provides some ground-plane functionality.

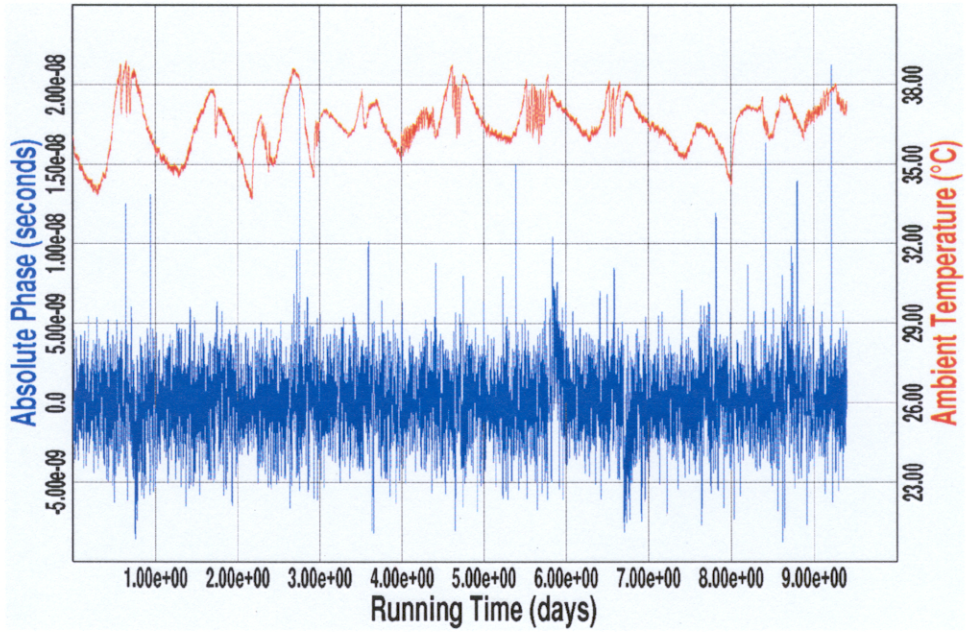

Figure 4 – GPS-Disciplined Rubidium Residuals 14-24 Nov. 2001

Figure 5 shows the time-interval measurements of the CDMA receiver 1PPS versus the GPS 1PPS plotted with the ambient temperature. Data were collected at 10-second intervals and the plot was smoothed over ten samples. The propagation delay is about 2.5 microseconds. The peak-to-peak phase “wander” of about 600 nanoseconds, not seemingly diurnal in nature, seems to be typical of this base station, the timing sub-system of which is believed to have been supplied by Lucent [5].

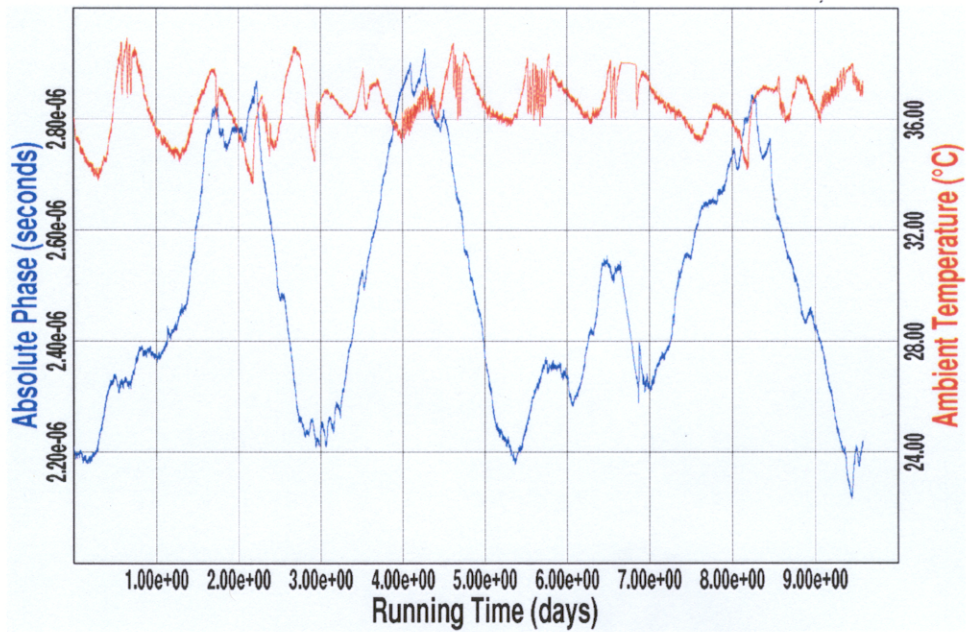

Figure 5 - CDMA 1PPS vs. GPS 1PPS Phase 14-24 Nov. 2001



Figure 6 shows the Allan deviation of these time-interval measurements, again with 10 sample smoothing applied to the raw time intervals. The short-term stability is similar to what would be expected from a conventional direct GPS receiver with an equivalent oscillator. The longer-term stability is degraded relative to direct GPS due to the characteristics of this particular base station. It is not known if this wander is typical of all Lucent-supplied GPS timing sub-systems.

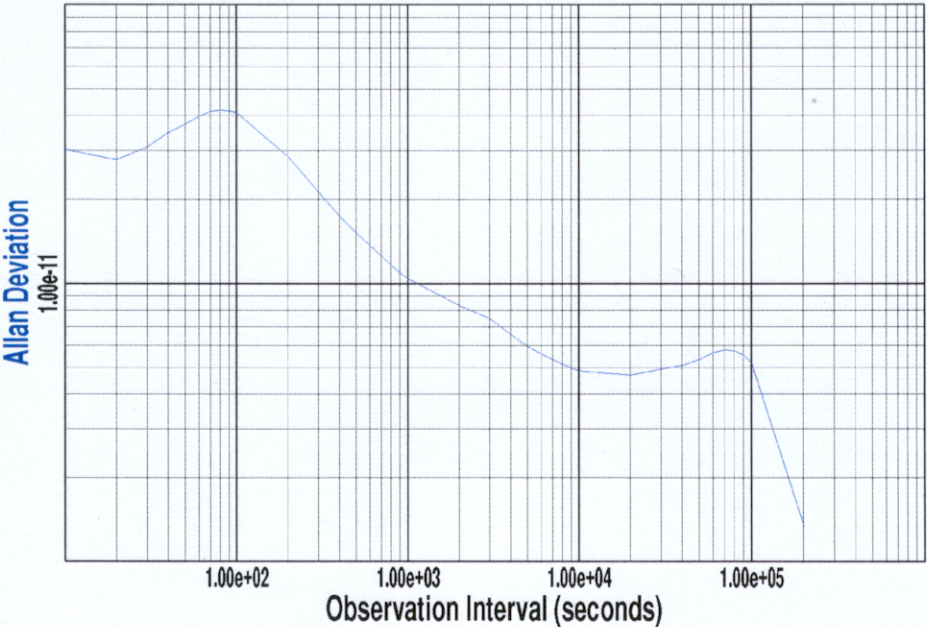

Figure 6 – CDMA 1PPS vs. GPS 1PPS Allan Deviation 14-24 Nov. 2001

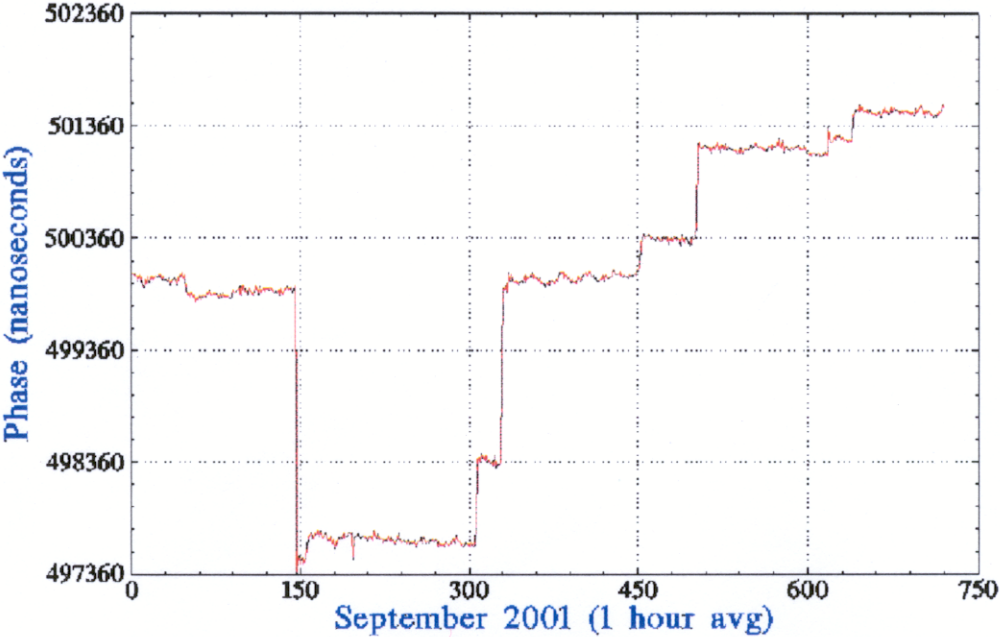

Figure 7 – CDMA Receiver TCXO 10 MHz Phase vs. UTC (NIST) September 2001

Figure 7 was provided by Michael Lombardi of the National Institute of Standards and Technology (NIST) in Boulder, CO [6]. It shows data collected over the month of September 2001 on one of these CDMA receivers equipped with the standard temperature-compensated crystal oscillator (TCXO). The 10 MHz output was divided down to 1PPS and compared against the UTC (NIST) timescale. As such, it provides information only about the frequency accuracy and stability.

Status logging was not performed during the logging period, so the exact cause of the phase steps is not known. They could be either from base station switching or short outages, during which the 10 MHz TCXO frequency would accumulate phase error fairly quickly. Since the CDMA receiver algorithms currently do not attempt to maintain strict coherence between the phase of the 10 MHz output and the 1PPS output following periods of signal outage, these accumulated phase errors would persist exactly as shown by Figure 7. Phase shifts of the magnitudes shown in Figure 7 would not be seen with higher stability disciplined oscillators.

Of particular interest in these data is the much better phase stability during the long, continuous tracking intervals. The deviation appears to be diurnal with about 100 nanoseconds of peak-to-peak movement. It is believed that the timing sub-system for this base station was provided by Motorola [5]. It is not known if this performance is typical of Motorola-supplied GPS timing sub-systems.

## CONCLUSIONS

A new technology has been introduced that offers a promising alternative for terrestrial-based time and frequency dissemination using modern wireless techniques. CDMA mobile telecommunications background information, including system standards and signal characteristics, and a timing and frequency optimized receiver architecture have been presented. Performance limitations have been discussed, and long-term data taken by two independent sources in two geographically remote locations have been presented. These indicate the reliability and performance capabilities of the new technology. The economic and practical advantages of indoor operation are gained with only a marginal tradeoff in performance relative to conventional, direct GPS. Since the introduction more than a year ago of products based on this technology, this tradeoff has proven acceptable to a large class of timing and frequency users.

## REFERENCES

- [1] "Mobile Station-Base Station Compatibility Standard for Wideband Spread Spectrum Cellular Systems," TIA/EIA Standard 95-B, Telecommunications Industry Association, Arlington, Virginia, USA, March 1999.
- [2] "Recommended Minimum Performance Standards for Base Stations Supporting Dual Mode Spread Spectrum Systems," TIA/EIA Standard 97-D, Telecommunications Industry Association, Arlington, Virginia, USA, June 2001.
- [3] James Cigler, Sr. RF Engineer – System Performance, Verizon Wireless, teleconversations during November 2001.
- [4] J. S. Lee and L. E. Miller, 1998, **CDMA Systems Engineering Handbook** (Artech House Publishers, Boston), ISBN 0-89006-990-5.
- [5] CDMA Development Group, CDMA Regional Worldwide Database, World Wide Web document <http://www.cdg.org/world/region.asp?region=North+America>, November 2001.

[6] M. Lombardi, NIST Time & Frequency Division, e-mailed phase data plotted November 2001.