

A SET OF SCALABLE MASTER CLOCK SYSTEMS BASED ON COMMERCIAL OFF-THE-SHELF (COTS) PRODUCTS

**G. Shaton
Eagle Alliance
132 National Business Parkway
Annapolis, MD 20701, USA
E-mail: gshaton@eagle-alliance.com**

Abstract

In any large telecommunication network, stable clocks are necessary to ensure the reliable transmission of information. The paper explores the development of a solution to this problem by creating a scaleable group of Master Station Clock systems. These systems are based upon using commercially available GPS-based hardware manufactured by TrueTime, Inc. These systems generate the signals required to provide syntonization and synchronization to a worldwide communication network using of TDM, SONET, IP, and ATM technologies.

INTRODUCTION

In 1997, it became apparent that the GPS Station Clocks in use in our extended enterprise were either at end of life (cesium-based) or were not providing the required stability for error-free network performance (rubidium- and crystal-based). In addition, the signal distribution hardware was approaching the end of its useful life. A decision was made to develop a new set of Master Station Clock systems for deployment at these communications facilities, rather than just replacing the existing devices.

PROBLEM AND SOLUTION

The first decision the designers faced was to use the best of class for each functional device or a systems approach where devices from a single vendor were used to create systems. The previous approach was to select devices based on their ability to provide the optimal solution for that function. However, this was proving to be a logistical nightmare for the repair depot, which had to contract with many manufacturers to provide support to the enterprise. The other choice was to determine if a single source could meet at least 90 percent of our critical requirements and provide a systems approach to our problem. The choice was clear use the single vendor systems approach.

Since our facilities ranged in size from huge multi-room nodal communications centers to small sites supporting limited users, we needed a series of Master Station Clocks that could be built using scalable building blocks. Using the systems approach made this part of the design less complex.

Next, the Primary Reference Source (PRS) needed to be addressed. This main issue was do we continue to use atomic standards or move to GPS-based sources to provide the PRS. The previous design was to use cesium and rubidium oscillators as the PRS devices. A cesium-based PRS, while extremely stable and accurate, does have certain undesirable problems, such as the life of the cesium tube and the fact that cesium devices must be shipped as a hazardous material. Stand-alone rubidium oscillators could not provide the required stability for the extended enterprise. Using GPS receivers as the PRS could provide the required stability, but if the signal from space was lost, so would be our stable source of timing. The final decision was to use GPS receivers to discipline rubidium oscillators as the PRS. At certain major nodal communications facilities, we would also retain external cesium oscillators as backup timing sources in case of a systemic problem with the NAVSTAR GPS constellation.

Having made this choice, the designers now were faced with which GPS signal in space to use, the SPS (C/A code) only on L1 or the PPS (P (Y) code) on both L1 and L2. This decision was easy; the Secretary of Defense had mandated that Department of Defense entities deploying GPS-based services must use the PPS service for our type of service.

Under this effort, the engineering group developed a family of commercial off-the-shelf (COTS) based Master Station Clocks for current and future use in providing timing to all our communication facilities worldwide. This is a group of scaleable solutions to provide modern Station Clock signals to current, legacy, and future equipment installed in our communication facilities. It provides for incremental upgrading of the devices as changes to the GPS signals in space occur (L5 and M-Code, for example) and the needs of our facilities change. TrueTime, Inc. manufactures the COTS products chosen for this solution. The systems are based on TrueTime's P (Y) and C/A Code GPS receivers and their 56000 Series Distribution Chassis (DRC). Nine standard versions of the DRC (some with variations) and 11 systems have been defined. The basic features of these devices are shown in Table 1 and Table 2.

SYSTEM EXAMPLES IN THE PROJECT

All of the systems developed under this project share certain common features as shown in Table 3. These features are common from the simplest system to the most complex system.

In the following sections, the details of two systems will be examined. A solution for a small site with a known, fixed timing requirement for which a System 9 is the optimal solution and the solution for a more complex site where the requirements exceed that of a small site or more clock signals are required than just 128 Kbps RS-422 clock signals.

SOLUTIONS FOR A SMALL SITE

The following systems are similar to the System 9 discussed below: System 2, System 3, System 6, System 7, and System 8. The differences are shown in Table 2. The following is a discussion of the System 9 currently being deployed at small sites. Refer to Figure 1 for the block diagram of a System 9.

The P (Y) and C/A Code GPS signals are received by the dual L1/L2 Antennas normally mounted on the roof of the building, which houses the site's communication center. The RF signals are converted to an optical signal in the Ortel Fiber Optic Transmitter and placed on the single-mode fiber-optic cables that enter the sites communication center. After passing through the LGX, the optical signals enter the Ortel

Fiber Optic Receivers and are converted back to an RF signal (exact copy of the RF signal received by each antenna). The outputs of the Ortel receivers are connected to the antenna inputs of the P (Y) GPS receivers. The outputs of the GPS receivers, 10 MHz, IRIG-B, 1 PPS, and *status* are connected to the (V) 8 DRC via coax cables. The user can also connect a RS-232 terminal to the GPS receiver through the serial I/O port. The DRC contains the appropriate rate generation modules to provide the following outputs:

12 each RS-422 balanced NRZ clock signals to drive encryption devices, CSU/DSUs and other equipment. The rates are from 8 KBps to 4.096 MBps. As shipped from the factory, they are set at six each of 1.544 MBps and 1.536 MBps.

Six each optical 128 KBps clock signals that when used with the 150-706 optical converters provide clock signals to plain text multiplexers and other equipment.

Four each optical IRIG-B serial TOD signals that when used with the 144-698 optical converters provide either serial time code to digital clocks or mission processing equipment.

One each command/control port used to program the programmable rate modules and obtain status information on the DRC.

One each set of contact closures to provide a summary *alarm* status of the DRC chassis.

This group of small site solutions does not permit much expansion should the site's timing requirements increase in the future. Several additional rate modules can be added without problems, but if additional DRCs are required, careful planning will be necessary to avoid total station outages. Addition of *slave* DRC chassis will require that the existing total solution chassis be converted to a *master* DRC. Also, the current rate modules will be moved to the new *slave* DRC. Handling of the plain text clock requirements might still be met by using the existing optical isolation modules, or a new plain text *slave* DRC may be required.

SOLUTIONS FOR A LARGER SITE

The following systems are similar to the System 1 discussed below: System 10, System 10-1, System 10-2, and System 11. The differences are shown in Table 2. The following is a discussion of the System 1, which is the basis of the design for medium and larger sites. System 10-1s are currently being installed as replacements for the PRSs at existing some existing sites. The intent is to add additional DRC chassis to complete the site Master Station Clock upgrades at a future date. System 10-2 was created to solve the specific needs of a special site where both communication and mission timing needs could be met with this unique system. System 11 will be the basic timing system installed at site where ATM or WAN CORE sites. Refer to Figure 2 for the block diagram of a typical Station clock installation at this class of sites. This example shows only one encrypted and one plain text slave chassis; however, additional slave chassis can be added as required by the clocking requirements at a specific communication center.

If more *slave* chassis are required, additional chassis can be added. In this case, care must be taken in how the 10 MHz and IRIG-B optical references are distributed. The preferred method is to connect the appropriate references to the *master* chassis. However, in a very large communications center this may not be practical. In this case, the designer should use *sub-master*, (V) 9, chassis and then reference the *sub-master* chassis to the *master* chassis. The *slave* chassis would then be referenced to the closest *sub-master*. Another acceptable method is to daisy chain the *slave* chassis. The maximum number of DRCs in a daisy chain is four.

Slave chassis should be placed in the communication facility so that the copper clock lines do not exceed 200 cable feet. This is to control the amount of noise and signal attenuation on the individual clock lines.

The P (Y) and C/A Code GPS signals are received by the dual L1/L2 Antennas, which are normally mounted on the roof of the building that houses the site's communication center. The RF signals are converted to an optical signal in the Ortel Fiber Optic Transmitter and placed on the single-mode fiber optic cables, which enter the sites communication center. After passing through the LGX, the optical signals enter the Ortel Fiber Optic Receivers and are converted back to an RF signal (exact copy of the RF signal which as received by each antenna). The outputs of the Ortel receivers are connected to the antenna inputs of the P (Y) GPS receivers. The outputs of the GPS receivers, 10 MHz, IRIG-B, 1 PPS, and *status* are connected to the (V) 1 *master* DRC via coax cables. The user can also connect a RS-232 terminal to the GPS receiver through the *serial I/O* port. The reference outputs from the *master* DRC, 16 each 10 MHz and 16 each IRIG-B are all on multi-mode fiber optics. These outputs are used as the inputs to the *slave* DRCs. The rate generation modules provide the user output signals from the *slave* DRCs. The types of outputs are given in Table 4. In addition, each DRC has the following two outputs:

One each command/control port used to program the programmable rate modules and obtain status information on the DRC.

One each set of contact closures to provide a summary *alarm* status of the DRC chassis.

REFERENCES

G. Shaton, 2001, "Timing Architecture for a DoD Network," Internal Department of Defense Agency Document, Fort George G. Meade, Maryland, USA, April 2001.

Table 1: Features of Standard Project DRC Chassis

DRC	TrueTime p/n	Features	Master/ Slave
(V) 1	471-001	Dual Rubidium Oscillator, all outputs are optical	Master
(V) 2	471-002	Basic distribution DRC for Frequency and Timing, no distribution modules	Slave
(V) 2-1	471-002-1	A (V) 2 chassis w/ 6 each 1, 5, and 10 MHz copper outputs	Slave
(V) 2-2	471-002-2	A (V) 2 chassis w/ 12 each 5 MHz, 6 each Balanced programmable (8 KBps - 4.096 MBps), 1PPS, and IRIG-B copper outputs	Slave
(V) 2-3	471-002-3	A (V) 2 chassis w/ 6 each 1, 5, and 10 MHz and 12 each T-1 AMI Bi-Polar copper outputs	Slave
(V) 3	471-003	Dual Hi-Stability Quartz Oscillators, Optical Outputs: 4 each IRIG-B, and 6 each 128 KBps; Copper outputs: 6 each 1.544 MBps and 6 each 1.536 MBps	Master
(V) 4	471-004	Dual Rubidium Oscillators and 12 each 1, 5, or 10 MHz sine wave outputs	Master
(V) 5	471-005	Distribution chassis with 72 Balanced programmable (8 KBps - 4.096 MBps) outputs (must use external DC power supply)	Slave
(V) 5-1	471-005-1	Distribution chassis with 36 Balanced programmable (8 KBps - 4.096 MBps) outputs	Slave
(V) 6	471-006	Triple Redundant NTP Server Chassis	Slave
(V) 7	471-007	Basic distribution chassis for Frequency, no distribution modules	Slave
(V) 7-1	471-007-1	A (V) 7 chassis with 12 each T-1 AMI Bi-Polar copper outputs	Slave
(V) 7-2	471-007-2	A (V) 7 chassis with 12 each T-1 AMI Bi-Polar copper outputs	Slave
(V) 8	471-008	Dual Rubidium Oscillators, Optical Outputs: 4 each IRIG-B, and 6 each 128 KBps; Copper outputs: 6 each 1.544 MBps and 6 each 1.536 MBps	Master
(V) 9	471-009	Dual Hi-Stability Quartz Oscillators, Optical 10 MHz and IRIG-B Outputs (Used in Major installations where a V (1) can not provide sufficient optical signals)	Sub-Master

Table 2: Features of the Project Master Clock Systems

System	TrueTime p/n	Features	Primary Use
(S) 1	470-001	Dual P (Y) GPS Receivers Master DRC, (V) 1 2 Slave DRC, (V) 2 No distribution modules provided UPS to support Master DRC	Basic System for use at sites requiring extensive distribution
(S) 2	470-002	Dual P (Y) GPS Receivers Master DRC, (V) 3, Limited Optical/Copper distribution	Complete system for use at sites requiring minimal distribution
(S) 3	470-003	Dual C/A GPS Receivers Master DRC, (V) 3, Limited Optical/Copper distribution	Complete system for use at non-critical sites requiring minimal distribution
(S) 4	470-004	Dual C/A GPS Receivers Master DRC, (V) 4 Low Phase Noise Analog Chassis	System for use at SATCOM sites to provide LO to modems
(S) 5	470-005	Dual P (Y) GPS Receivers Master DRC, (V) 4 Low Phase Noise Analog Chassis	System for use at SATCOM sites to provide LO to modems
(S) 6	470-006	Single C/A GPS Receivers Master DRC, (V) 3, Limited Optical/Copper distribution	Complete system for use at non-critical sites requiring minimal distribution
(S) 7	470-007	Dual P (Y) GPS Receivers Master DRC, (V) 3, Limited Optical/Copper distribution	Complete system for use at sites requiring minimal distribution
(S) 8	470-008	Single P (Y) GPS Receivers Master DRC, (V) 8, Limited Optical/Copper distribution	Complete system for use at sites requiring minimal distribution
(S) 9	470-009	Dual P (Y) GPS Receivers Master DRC, (V) 8, Limited Optical/Copper distribution	Complete system for use at sites requiring minimal distribution
(S) 10	470-010	Dual P (Y) GPS Receivers Master DRC, (V) 1 1 Slave DRC, (V) 2 No distribution modules provided	Basic System used to replace Cesium at existing site
(S) 10-1	470-010-1	Dual P (Y) GPS Receivers Master DRC, (V) 1 1 Slave DRC, (V) 2-1 Sine wave distribution modules	Basic System used to replace Cesium at existing site
(S) 10-2	470-010-2	Dual P (Y) GPS Receivers Master DRC, (V) 1-1 1 Slave DRC, (V) 2-2	Special System used to provide communications and user signals at a specific site
(S) 11	470-011	Dual P (Y) GPS Receivers Master DRC, (V) 1 1 Slave DRC, (V) 2-3 1 Slave DRC, (V) 7-2 Sine wave and T1/E1 distribution modules	Basic System used at ATM/WAN sites

Table 3: Common Features of the Project Systems

FEATURE	BENEFITS
Optical Antenna Fed	Protects GPS receiver from Lightening Damage Do not need to use antenna line amplifiers EMI/RFI problems eliminated
Optical Distribution of References	Minimizes noise on Reference lines Permits all Slave DRCs to be referenced to the same MASTER DRC
DRCs w/mid-backplane	Active Front Modules and Passive Rear Modules Can use different connector modules w/ same Rate generation module
Redundant Oscillators	Prevent single point of failure
Redundant Power Supplies	Prevent single point of failure
Interchangeable rate modules	Customize DRCs for each site's requirements
Defined upgrade path for H/W	Prevents obsolescence

Table 4: Rate Module Outputs

MODULE	OUTPUT TYPE	OUTPUTS/ MODULE	USUAL CONNECTOR
560-5155-1	Sine Wave	6	BNC
560-5155-2	Square Wave	6	BNC
560-5153	AMI Bi-Polar	6	DE-9
560-5170	RS-422 Balanced	6	TWINAX
560-5181-1	Modulated 1 KHz Sine wave IRIG-B	6	BNC
560-5181-2	1 PPS	6	BNC
560-5183-1	IRIG-B	4	ST Optics
560-5183-2	1 PPS	4	ST Optics

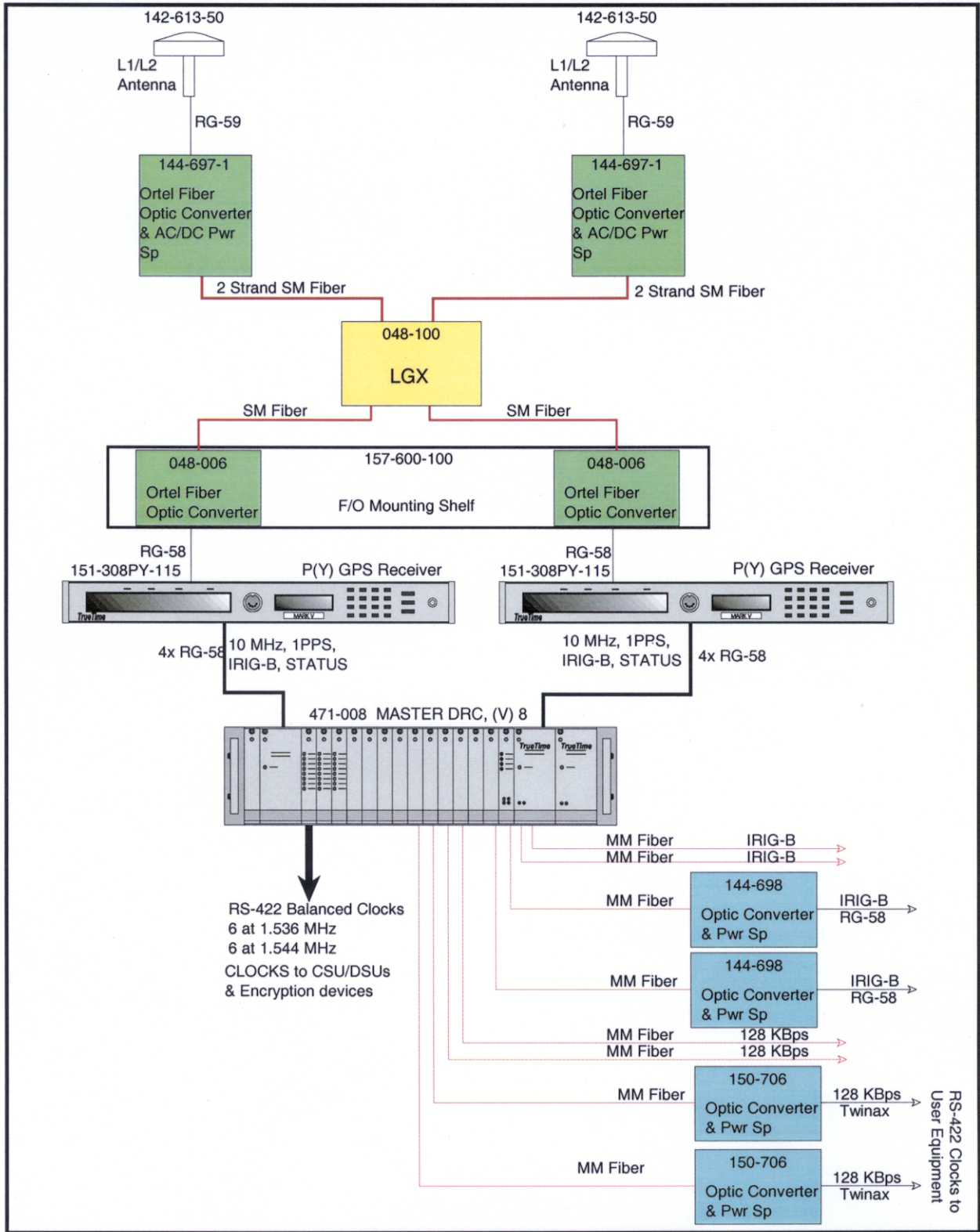

Figure 1: Block Diagram of SYSTEM 9.

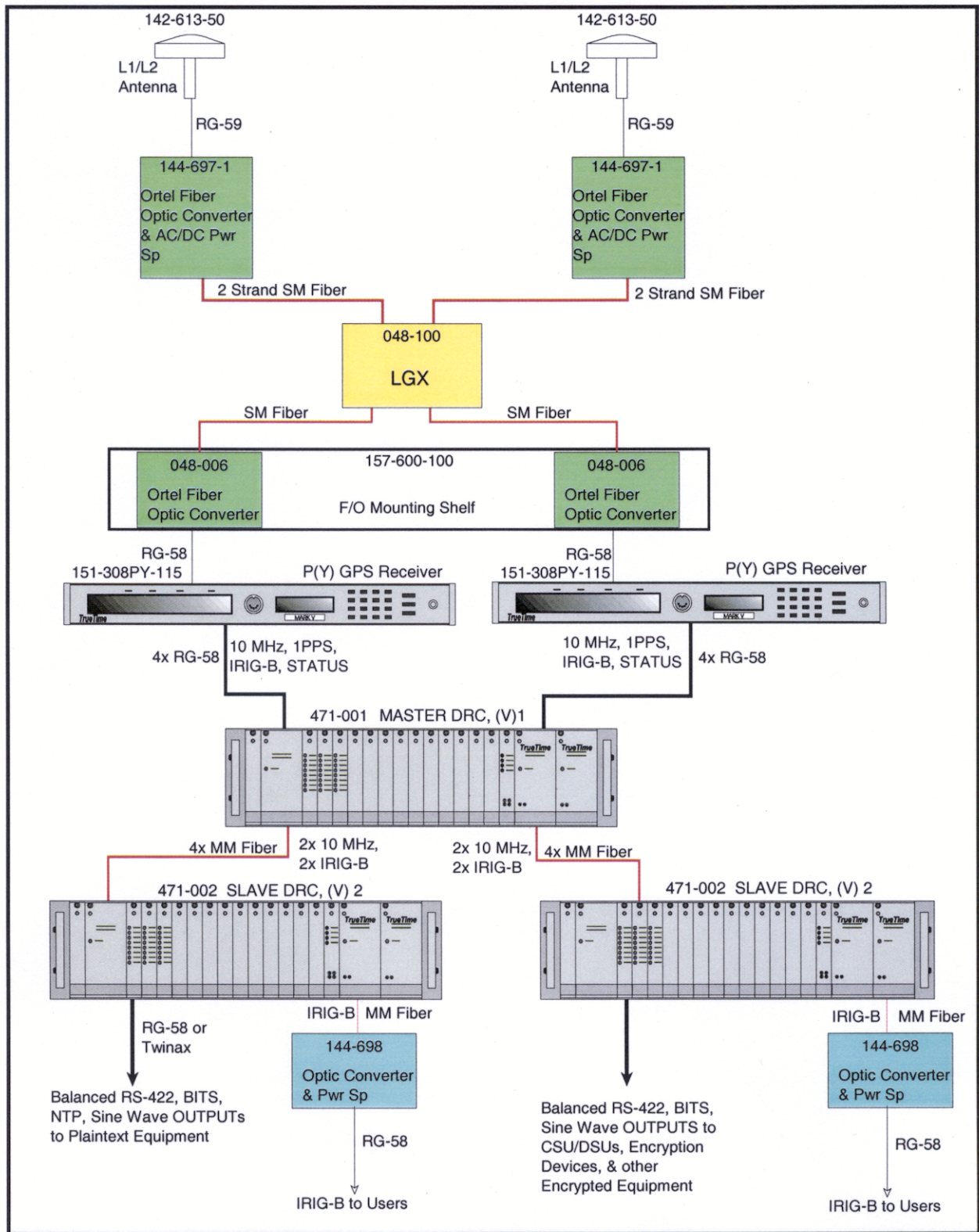

Figure 2: Block Diagram of SYSTEM 1.

QUESTIONS AND ANSWERS

GEORGE SHATON: I guess I should plug the company. We chose TrueTime hardware at the time. They were the only ones that could deliver the P-Y receiver that we were required to use.

NEDAL SWEDAN (TrueTime, Inc.): I have a question for you. When you were making a decision on your reference and you had a choice between cesium and SASM, what were the criteria that made you decide on SASM versus cesium?

SHATON: We chose GPS because we required a worldwide frame of reference. One of the problems that we had with cesium, although it is Stratum 1 or better, was that when we looked at our deployment, which is worldwide in nature, we were seeing some issues with cesium that would give us the MTIE, which is an error measurement that we required. Plus, we also were told by our logistics people that cesium was considered hazardous material and it was – there were difficulties in moving it around quickly through the transportation system. And GPS was the mandate for the timing. The Department of Defense is required to have its time references to USNO. And the easiest way to get that is through GPS these days.