

# TWSTFT NETWORK STATUS IN THE PACIFIC RIM REGION AND DEVELOPMENT OF A NEW TIME TRANSFER MODEM FOR TWSTFT

M. Imae<sup>1</sup>, M. Hosokawa<sup>1</sup>, Y. Hanado<sup>1</sup>, Z. Li<sup>2</sup>,  
P. Fisk<sup>3</sup>, Y. Nakadan<sup>4</sup>, and C. S. Liao<sup>5</sup>

<sup>1</sup>Communications Research Laboratory (CRL), Japan

<sup>2</sup>Shaanxi Astronomical Observatory (CSAO), China

<sup>3</sup>National Measurement Laboratory (NML), Australia

<sup>4</sup>National Research Institute of Metrology (NRLM), Japan

<sup>5</sup>Telecommunication Laboratories (TL), Taipei, Taiwan

## Abstract

*Two-Way Satellite Time and Frequency Transfer (TWSTFT) is one of the most precise and accurate time transfer techniques. Recently TWSTFT results among the European and North American time and frequency institutes have been started applying to the TAI calculation. A TWSTFT network in the Pacific Rim region is also being developed rapidly. CRL and NRLM in Japan, NML in Australia, CSAO in China, and TL in Taiwan have been doing TWSTFT time transfer on a regular basis. Some other institutes, such as KRIS in South Korea and PSB in Singapore, are also planning to join this network within 1 year. By performing TWSTFT time transfer it became obvious that several problems in TWSTFT should be solved for practical use and contribution to TAI with the full performance of TWSTFT. We have been developing a new time transfer modem to solve or reduce most of these problems with TWSTFT. It has three PRN code modulator units for transmission and eight PRN code demodulator and time-interval measurement units for receiving. It realizes simultaneous time transfer among up to eight stations.*

## INTRODUCTION

Research and development of the atomic clocks and primary frequency standards realize improvement of the stability and accuracy of the International Atomic Time (TAI) and Coordinated Universal Time (UTC). The stability of TAI and UTC is currently about  $2 \times 10^{-15}$  over a few weeks. It is also predicted that the stability of TAI and UTC will reach a few parts in  $10^{16}$  within 10 years. Thus, the new precise time and frequency transfer methods are being investigated in the time and frequency community. They are based on GPS carrier-phase measurements, GPS/GLONASS multi-channel C/A code measurements [1], and Two-Way Satellite Time and Frequency Transfer (TWSTFT). This paper relates to the TWSTFT method.

The concept of TWSTFT is very old. TWSTFT experiments were made around 1970; these experiments showed very high time transfer precision [2-3]. However the TWSTFT method

was not used as a regular time transfer method until 1990's. One of the main reasons is that the TWSTFT method has very high capabilities for precise and accurate time transfer, but it needs expensive facilities and has a high running cost compared with the one-way method, such as GPS common-view.

But the progress of atomic clocks and primary frequency standards require more precise time transfer techniques, so the TWSTFT method has been widely investigated in time and frequency standard institutes [4-8]. Especially in Europe and North American area, the regular TWSTFT has been performed to contribute to the TAI calculation [9]. As we reported at PTTI'98 [10], major T&F institutes in this region are making effort to construct a TWSTFT network there.

## TWSTFT NETWORK IN THE PACIFIC RIM REGION

The history of the construction of TWSTFT network in the Pacific Rim region and its present status are shown in Table 1. Due to several problems for each time transfer link, such as failure of the earth station and change of the transponder of the satellite, some of them were interrupted after the start of the operation. But as shown in Fig. 1, the time transfer links shown by black solid lines are operating or going to re-start in the very near future. In addition these links, PSB in Singapore and KRISS in South Korea, will join to this network around the middle of 2001.

Table 1 History and present status of the TWSTFT network in the Pacific Rim region

Link	Start epoch	Satellite	Frequency band	Status
CRL-NML	October 1997	INTELSAT 702, 176° E	Ku-band	Interrupted
CRL-CSAO	October 1998	JCSAT-1B, 150° E	Ku-band	Operating
CRL-NRLM	March 1999	JCSAT-1B, 150° E	Ku-band	Operating
CRL-TL	June 2000	JCSAT-1B, 150° E	Ku-band	Interrupted
NML-NIST	July 1999	INTELSAT 701, 180° E	C-band	Operating

## DRAWBACKS OF TWSTFT

TWSTFT has big advantages compared with the one-way methods, such as GPS common-view, but it also has several drawbacks:

- (1) difficulty of full automatic operation due to radio signal transmission to the satellite,
- (2) expensive cost of the satellite links,
- (3) difficulty of performing time transfer among more than three stations simultaneously using conventional time transfer modems, and
- (4) accurate evaluation of internal delays and delay variations in earth stations.

Due mainly to item (1), it is difficult to perform the time transfer just on TAI's calculation reference epoch, which is at 0:00 UTC every 5 days. In the case of GPS common-view, we have more than 30 common-view tracks between long-distance cases for each TAI's calculation epoch, but in the case of TWSTFT, we have only two or three time transfer results per week. So the estimation error for the reference epoch of TAI's calculation from the observed database is much larger than the precision of the each observation. Even in this case, the TWSTFT results have almost the same stability as GPS common-view.

## DEVELOPMENT OF A NEW TIME TRANSFER MODEM

To compensate for or minimize the drawbacks described in previous section, a new time transfer modem for TWSTFT is now under construction at CRL. Table 2 shows the main specifications of the new modem. As described in the table, the new modem uses a multi-channel method to perform time transfer experiments among more than three stations simultaneously.

Table 2 Specifications of the new time transfer modem

Modulation	Direct-sequence spread-spectrum method using PRN code
Modulation Channels	3 one for time transfer two for Earth station delay calibration
Demodulation or Receiving Channels	8 six for time transfer two for Earth station delay calibration
Clock rate of PRN code	2.04775 MHz or 2.0455 MHz
Bit length of PRN code	8191 bits (13 stage FSR) or 4091 bits (12 stage FSR)
Communication function	Communication function for data transmission among the participating stations
Remote control function	the modems on the slave stations can be controlled from the master station via Internet

### MULTI-POINT SIMULTANEOUS TIME TRANSFER USING THE NEW TIME TRANSFER MODEM

The time transfer concept using this new modem with four stations is shown in Fig. 3. Each station transmits a time transfer signal that is modulated using the spread-spectrum method. The pseudo-random noise code for the modulation used at each station is different. All of the received signals at the satellite are combined and retransmitted back to the ground. The multi-channel receiving section at each station demodulates the signals from the satellite and makes arrival time measurements using the station reference clock. The time differences for all the pairs of participating stations can be calculated by exchanging the measured data. Thus, the time transfer of all pairs of participating stations can be performed simultaneously.

The following equations explain the above principle. As shown in Fig. 3, we assume that four stations are participating the TWSTFT, and  $T_a$ ,  $T_b$ ,  $T_c$ , and  $T_d$  denote the time of the reference clock at each station.  $T_{a1}$ ,  $T_{a2}$ , and  $T_{a3}$  are the measured values at "station a" for the received signal from station b, c, and d, and they are expressed by the equations (1), (2), and (3), respectively.

$$T_{a1} = \Delta T_{ab} + T_{Ub} + \Delta T_s + T_{Da} \quad (1)$$

$$T_{a2} = \Delta T_{ac} + T_{Uc} + \Delta T_s + T_{Da} \quad (2)$$

$$T_{a3} = \Delta T_{ad} + T_{Ud} + \Delta T_s + T_{Da} \quad (3)$$

where  $\Delta T_{ij} = T_i - T_j$ ,  $T_{Uj}$  is the up-link signal propagation delay from the station j to the satellite,  $T_{Di}$  is the down-link signal propagation delay from the satellite to the station i, and  $\Delta T_s$  is internal signal delay in the satellite.

Equations (4), (5), and (6) are measured values at "station b."

$$T_{b1} = \Delta T_{ba} + T_{Ua} + \Delta T_s + T_{Db} \quad (4)$$

$$T_{b2} = \Delta T_{bc} + T_{Uc} + \Delta T_s + T_{Db} \quad (5)$$

$$T_{b3} = \Delta T_{bd} + T_{Ud} + \Delta T_s + T_{Db} \quad (6)$$

Equations (7), (8), and (9) are measured values at “station c.”

$$T_{c1} = \Delta T_{ca} + T_{Ua} + \Delta T_s + T_{Dc} \quad (7)$$

$$T_{c2} = \Delta T_{cb} + T_{Ub} + \Delta T_s + T_{Dc} \quad (8)$$

$$T_{c3} = \Delta T_{cd} + T_{Ud} + \Delta T_s + T_{Dc} \quad (9)$$

Equations (10), (11), and (12) are measured values at “station d,”

$$T_{d1} = \Delta T_{da} + T_{Ua} + \Delta T_s + T_{Dd} \quad (10)$$

$$T_{d2} = \Delta T_{db} + T_{Ub} + \Delta T_s + T_{Dd} \quad (11)$$

$$T_{d3} = \Delta T_{dc} + T_{Uc} + \Delta T_s + T_{Dd} \quad (12)$$

The time difference between clock i and clock j is expressed by equation (13).

$$\Delta T_{ij} = T_i - T_j = -(T_j - T_i) = -\Delta T_{ji} \quad (i, j = a, b, c, d) \quad (13)$$

The up-link and down link propagation delay between the earth station and the satellite are almost same, so they can be assumed as equations (14).

$$T_{Ui} = T_{Di} \quad (i = a, b, c, d) \quad (14)$$

By using above equations, we can easily obtain the all pairs of the time difference between the participating stations shown as equations (15) to (20):

$$\Delta T_{ab} = (T_{a1} - T_{b1})/2 \quad (15)$$

$$\Delta T_{ac} = (T_{a1} - T_{c1})/2 \quad (16)$$

$$\Delta T_{ad} = (T_{a1} - T_{d1})/2 \quad (17)$$

$$\Delta T_{bc} = (T_{a1} - T_{b1})/2 \quad (18)$$

$$\Delta T_{bd} = (T_{a1} - T_{c1})/2 \quad (19)$$

$$\Delta T_{cd} = (T_{a1} - T_{d1})/2 \quad (20)$$

These equations show the simultaneous time transfer between all pairs of the participating stations can be performed using the new modem.

## CONCEPT OF AUTOMATIC OPERATION

The new modem has the function to be controlled from the master station using the Internet. Table 3 shows the sequence to perform the TWSTFT session among the participating stations.

Table 3 Sequence of TWSTFF using the new modem

- 
1. The operator at the master station makes the arrangement to the satellite management organization,
  2. Distribution of time transfer parameters from master station to the slave stations,
  3. Wait until the start time,
  4. Start the carrier signal transmission from all of the participating stations,
  5. Automatically measure the received power level, frequency and C/No at each station,
  6. Control the transmission power at the slave station according to the command from the master station,
  7. Exchange the status of all of the channels used at each station,
  8. Wait the start epoch of the time transfer,
  9. Make time transfer operation and exchange the measured data among the participating stations,
  9. Finish the time transfer operation at each station.
- 

To do item 1, at least one person at the master station should make the communication with the satellite management organization, but no manpower is needed at the slave stations; this function realizes a large reduction in manpower and the performance of the time transfer exactly at TAI's reference time. It can reduce the initial synchronization time of the PRN code modulation signal by using the frequency information of the carrier signal from each station measured in item 5.

## MEASUREMENTS OF DELAY VARIATION OF THE EARTH STATION

The delay and delay variation in the earth station is one of the most significant error sources in the TWSTFT method. The new modem is able to monitor and compensate the transmission path and receiving path in the earth station. Fig. 4 shows the schematic diagram of the measurement of the internal delays of the earth station. A small portion of the transmission signal is transferred from the front end of the earth station to the modem. The calibration signal for the receiving path is transferred from the modem to the front end part of the earth station. These signals are transferred using same cable to cancel the delay and the delay variation due to the cable length change. After the frequency conversion, the transmission signal, and the calibration signal are fed to the new modem. Thus, delay and delay variation of the transmission path and the receiving path of the earth station are measured by the modem simultaneously performing the time transfer among the other stations.

## CONCLUSIONS

We described the present situation of the TWSTFT network in the Pacific Rim region. The number of the participating stations is increasing steadily. The TWSTFT has many advantages compared with the one-way methods, such as the GPS common-view, the GPS carrier phase, and the GPS/GLONASS multi-channel, but it also has several disadvantages. It is expected that the new type of the time transfer modem described in this paper is one of the solutions to eliminate or reduce the problems of TWSTFT.

By using this new time transfer modem, we can realize the following improvements in TWSTFT experiments:

- (1) shortened use of satellite time and reduced satellite link charges,
- (2) simultaneous time transfer among participating stations, and
- (3) lower manpower requirements.

Thus, it can be said that items (2) and (3) allow TWSTFT to be performed at the exact same time as TAI's calculation reference epoch.

## ACKNOWLEDGMENTS

We wish to thank all participants of the Pacific Rim TWSTFT network institutes for doing the time transfer on a regular basis. We also thank to the STA for the financial support for the development of the new time transfer modem.

## REFERENCES

- [1] W. Lewandowski, and C. Thomas 1991, "GPS time transfer," Proceedings of the IEEE, 79, 991-1000.
- [2] W. Markowitz, C. A. Lidback, H. Uyeda, and K. Muramatsu 1966, "Clock synchronization via Relay II satellite," IEEE Trans. Instrum. Meas., IM-16.
- [3] Y. Saburi, M. Yamamoto, and K. Harada 1976, "High-precision time comparison via satellite and observed discrepancy of synchronization," IEEE Trans. Instrum. Meas., IM-25.
- [4] D. Kirchner 1991, "Two-way time transfer via communication satellites," Proceedings of the IEEE, 79, 983-990.
- [5] D. Kirchner, 1999 "Two way satellite time and frequency transfer (TWSTFT): principle, implementation, and current performance," in Review of Radio Science, Oxford University Press, pp. 27-44.
- [6] Report of the 12th CCDS Meeting, BIPM, 1993.
- [7] G. de Jong 1998, "Delay stability of the TWSTFT earth station at VSL," in Proceedings of the 29th Annual Precise Time and Time Interval (PTTI) Systems and Applications Meeting, 2-4 December 1997, Long Beach, California, USA, pp. 241-252.
- [8] D. Kirchner, H. Ressler, P. Hetzel, A. Soring, and W. Lewandowski 1999, "Calibration of three European TWSTFT stations using a portable station and comparison of TWSTFT and GPS common-view measurement results," in Proceedings of the 30th Annual Precise Time and Time Interval (PTTI) Systems and Applications Meeting, 1-3 December 1998, Reston, Virginia, USA, pp. 365-376.
- [9] J. Azoubib, D. Kirchner, W. Lewandowski, et al. 1999, "Two-way satellite time transfer using INTELSAT 706 on a regular basis: status and data evaluation," in Proceedings of the 30th Annual Precise Time and Time Interval (PTTI) Systems and Applications Meeting, 1-3 December 1998, Reston, Virginia, USA, pp. 393-404.
- [10] M. Imae, M. Hosokawa, et al. 1999, "Two-way satellite time transfer activities in Asian-Pacific Region," in Proceedings of the 30th Annual Precise Time and Time Interval (PTTI) Systems and Applications Meeting, 1-3 December 1998, Reston, Virginia, USA, pp. 355-363.

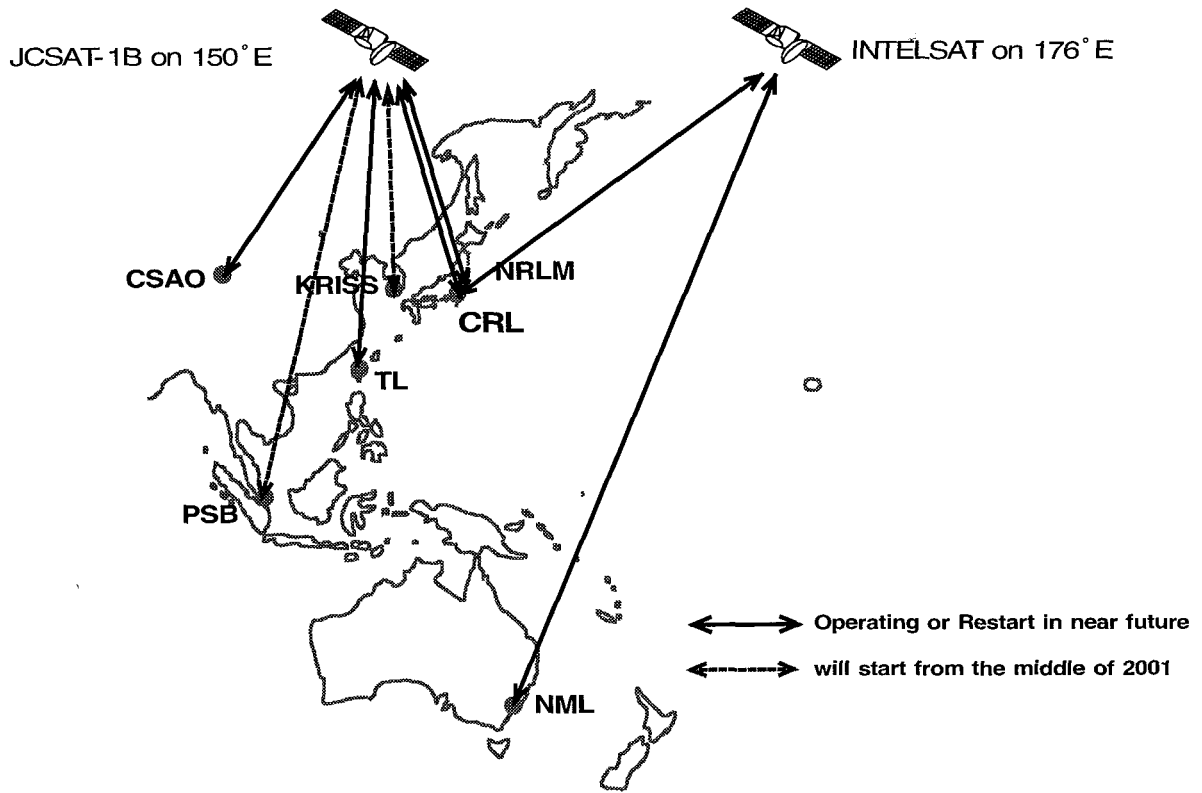

Fig. 1: The TWSTFT network in the Pacific Rim region.

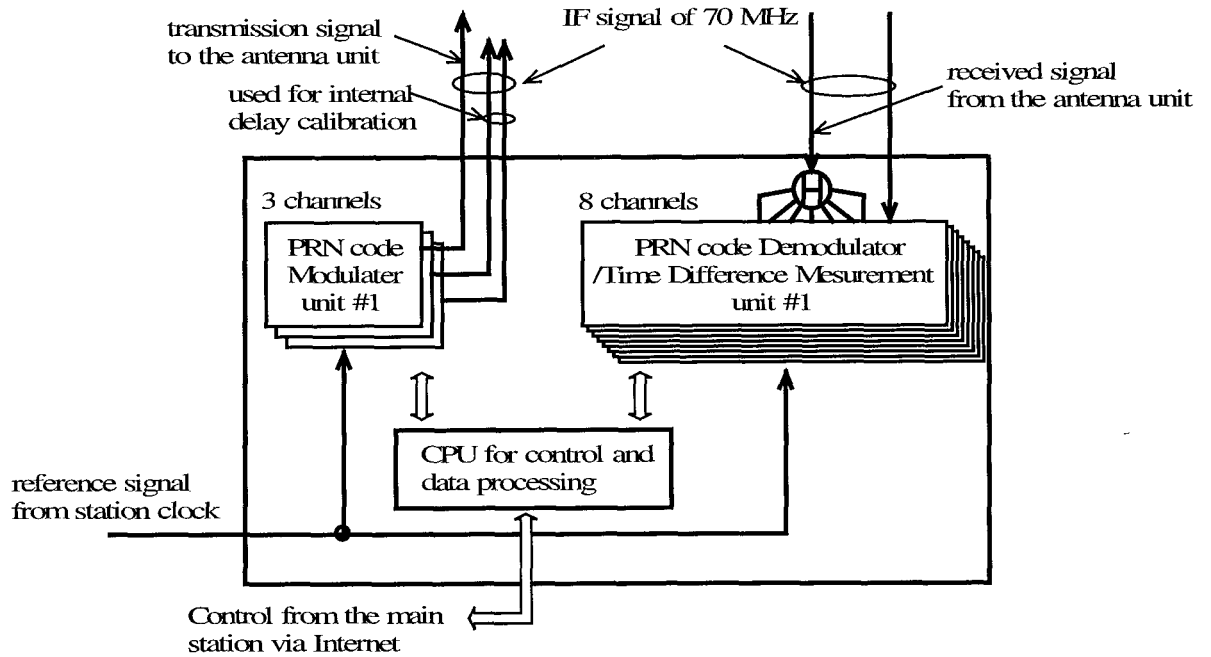

Fig.2: A block diagram of the new modem for the TWSTFT.

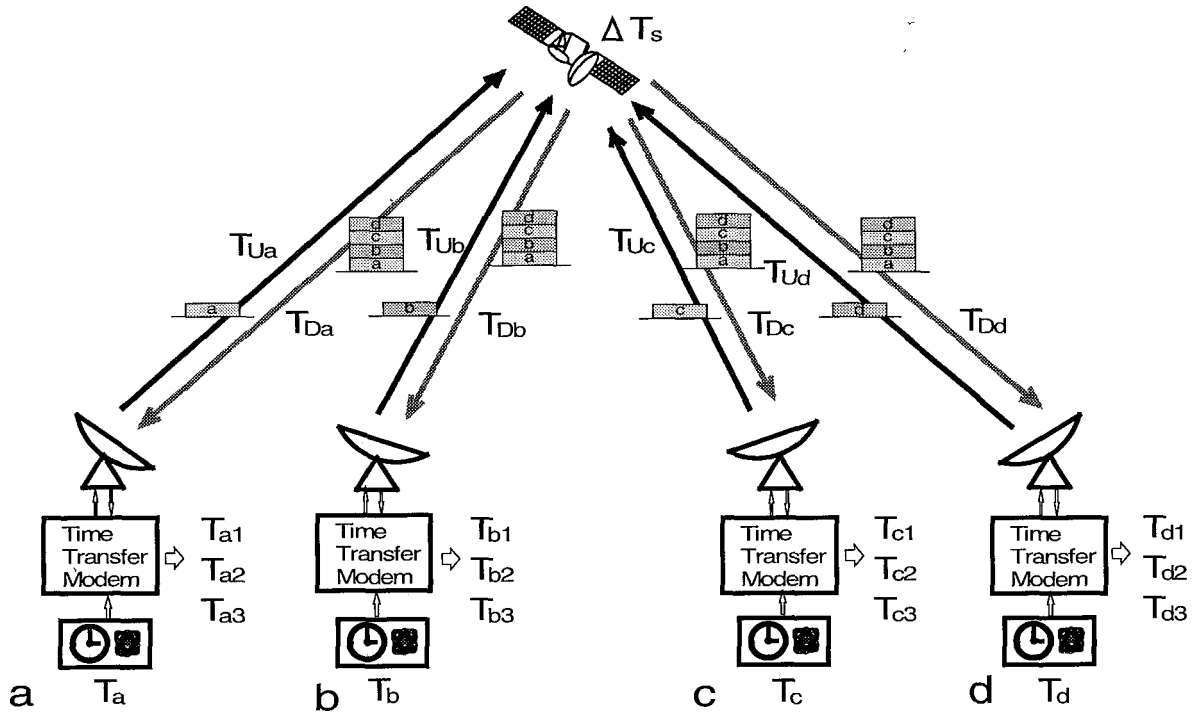

Fig. 3: A concept Multi-points simultaneous time transfer using the new modem.

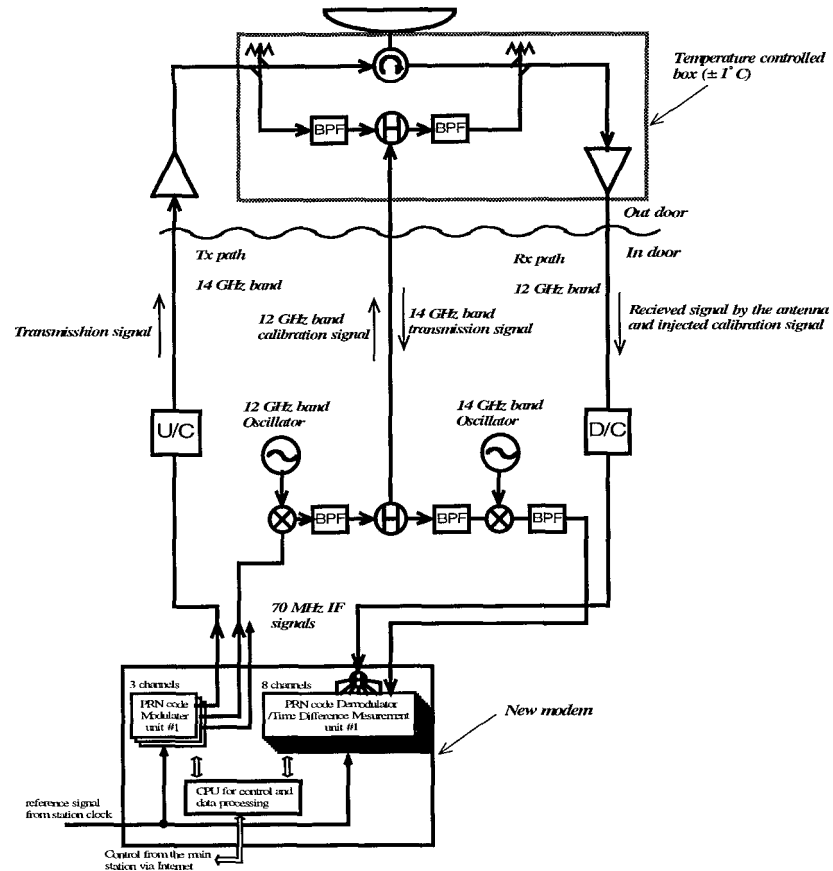

Fig. 4: A concept of the measurement of the internal delays in the earth station for TWSTFT.