

PRECISE TIME-TRANSFER EXPERIMENT USING TWO-WAY CARRIER-PHASE METHOD PLANNED FOR ETS-VIII SATELLITE

Mizuhiko Hosokawa, Michito Imae, Hitoshi Kiuchi, Yukio Takahashi
and Yasuhiro Takahashi
Communications Research Laboratory, Tokyo, Japan

Hiroyuki Noda and Naokazu Hamamoto
Tsukuba Space Center, National Space Development Agency of Japan

Abstract

A precise time and frequency transfer between the satellite-onboard atomic clocks and the ground reference clocks has been planned for the Engineering Test Satellite-VIII (ETS-VIII) under the collaboration between the Communications Research Laboratory (CRL) and the National Space Development Agency (NASDA). We will show the plan and the status report of this experiment.

ETS-VIII is a Japanese Geostationary Satellite, which will be launched in 2002. It has missions for mobile communication experiments and for precision timing experiments using atomic clocks in space. For the latter purpose, it will be equipped with two cesium-beam frequency standards, which were developed for GPS satellites.

CRL is conducting the precise time-and frequency-transfer experiment between the cesium atomic clock on ETS-VIII and the ground reference clock. For this experiment, a special time-transfer system, which was proposed by CRL, is now under development. In this system, we adopt a two-way time transfer method with the use of the carrier phase information for the precise timing measurement. This system also provides a function of compensating the internal delay variations of the transmission pass and the receiving pass in both satellite and ground station for accurate time transfer. It will attain a precision better than 10ps on the measurement of the time difference between on-board standards and the ground reference clocks. We have completed the on-board engineering model equipment and are constructing the prototype flight model.

INTRODUCTION

In Japan, the National Space Development Agency (NASDA)'s Engineering Test Satellite (ETS) series is aimed at developing satellite common base technologies. The Engineering Test Satellite VIII (ETS-VIII),

the launch of which is scheduled by an H-IIA launch vehicle from NASDA's Tanegashima Space Center in 2002, is developed primarily to establish and verify the world's largest geostationary satellite bus technology, which is necessary for space missions at the beginning of the 21st century. The ETS-VIII will conduct many orbital experiments. As one of them, the ETS-VIII will carry a highly precise clock system for satellite positioning experiments.

The atomic clocks of the system are the same type as is used for GPS satellites. The specification of them is shown in Table 1. Using the frequency of these clocks as the reference, the positioning signals in L band and S band, similar to GPS, will be transmitted. An antenna of 1.1 m diameter for both L band and S band is planned in the ETS VIII for sending and receiving these positioning signals. By using this antenna, the same order of the receiving power in the ground station as that of GPS is expected.

CRL has conducted the basic research on next generation global navigation system, such as the development of the spaceborne hydrogen maser and the precise time-transfer system between satellite and ground station. Based on this research, we have proposed a very accurate frequency/time comparison system for ETS VIII. The configuration of the system is shown in Fig. 1.

TIME COMPARISON EQUIPMENT (TCE) FOR ETS VIII

CRL has been developing the on-board unit of the precise frequency/time comparison system for ETS VIII that is called time comparison equipment (TCE). There are three features in this system. The first is the adoption of two-way signal transfer method between Earth station and Satellite. The second is the use of the signal carrier phase information. The third is the self-calibration function. Block diagram of the on-board TCE is shown in Fig. 2.

The advantage of the two-way method is that, due to both ground-to-satellite and satellite-to-ground signals propagating the same path in opposite directions, the delay caused in the ionosphere and the atmosphere can be canceled. Such cancellation reduces the main part of the measurement uncertainty and enables us to make the precise time comparison.

The use of carrier-phase information is available because both stations have the highly stable atomic clocks similar to the case of GPS. Since all of the modulation signals and carriers are made coherently, we can use the carrier phase information in addition to the modulated signals. This carrier phase information makes it possible to compare the timing of the signal on the order of a few pico seconds. In the on-board TCE, internal delay measurement function is equipped so that we can calibrate the delay time variation due to temperature variation or aging.

The link budget between ETS-VIII and the ground station and the estimated precision of the time comparison are shown in Table 2. As the antenna of the ground station, 1.8 m diameter antenna is assumed. This estimation shows that we can attain about 0.2 ns precision with the modulation signal only and ps-order time comparison is possible if we use the carrier-phase information.

APPLICATION

The main purpose of the experiment using TCE is the evaluation of the stability of the on-board atomic clocks. This high accurate time comparison can be used for many applications. For example, we are planning very accurate time transfer between ground stations via ETS-VIII.

Recently, satellite positioning experiment group has paid attention to the high precision of TCE. In addition to original positioning experiments, we are now discussing on the use of TCE for positioning experiment.

STATUS AND THE DEVELOPMENT SCHEDULE

The engineering model of TCE has been completed. Now it is under System Engineering Model (SEM) system test together with all other missions' equipment. Assembly and wiring of Payload Module (upper section of satellite structure) for mission equipment has been started at Melco/Kamakura Works in October, and then its functional test will be done until January 2000. The development of the flight model of TCE has also started. Next fiscal year we will start the construction of ground station. Toward the launch in 2002, we will make effort to complete the time comparison system using TCE.

REFERENCES

NASDA ETS VIII home page, http://yyy.tksc.nasda.go.jp/Home/Projects/ETS-VIII/index_e.html

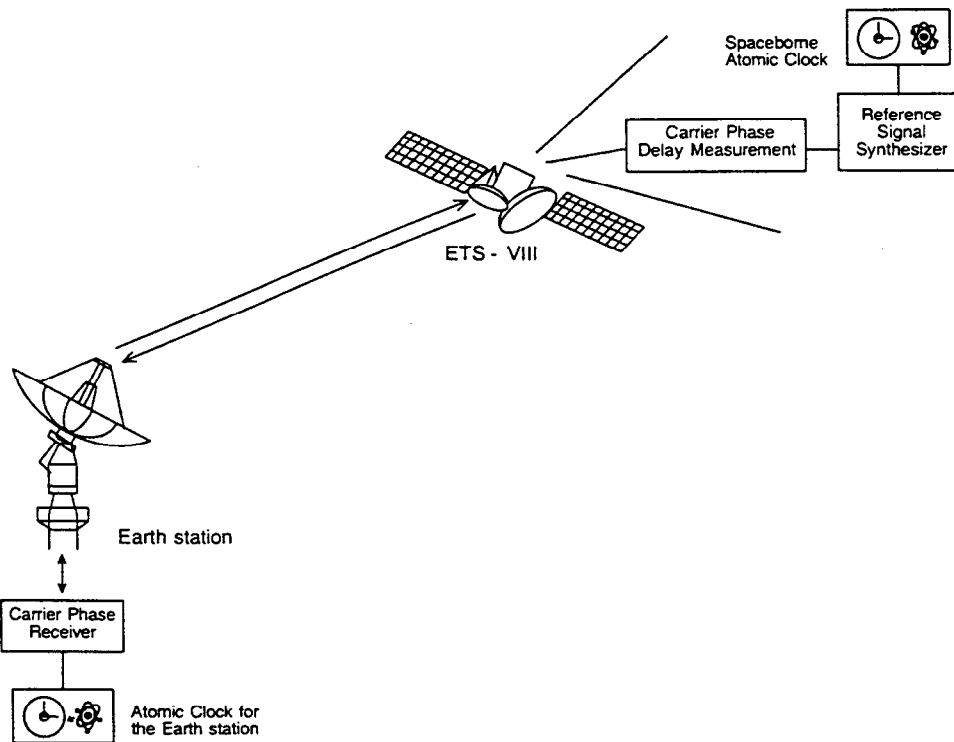

Figure 1. Illustration of the time comparison between satellite and ground

Table 1. Specification of the on-board clocks

Cs atomic clock for GPS BLOCK IIR		
frequency stability	6×10^{-12}	(1sec.)
	2×10^{-12}	(1min.)
	6×10^{-13}	(1hour)
	6×10^{-14}	(1day)
	6×10^{-14}	(1year)

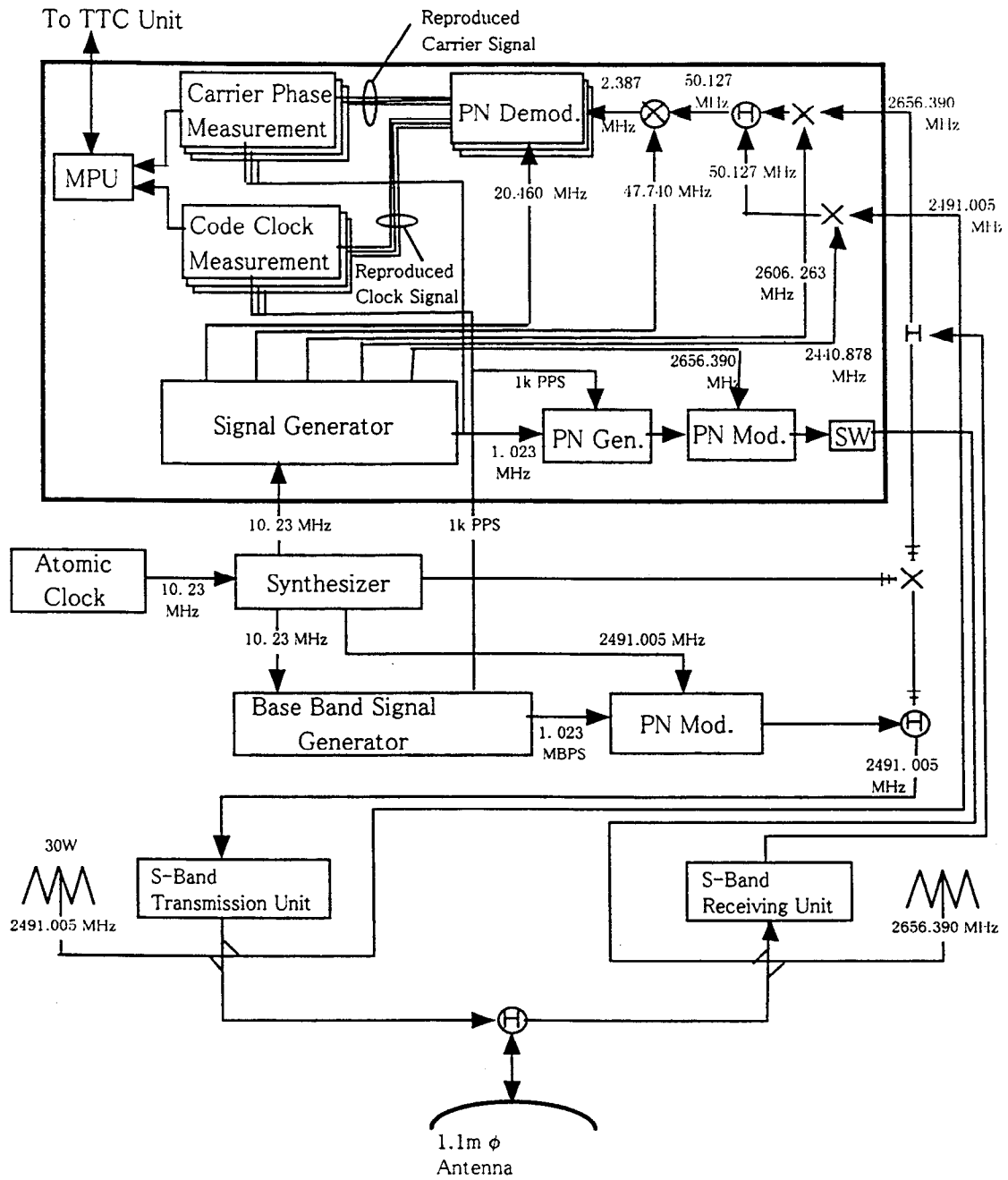

Figure 2. Block diagram of on-board TCE

Table 2. Link budget

		S band	S band	L band
	Earth(E) to	Satellite(S)	S to E	S to E
	Carrier code clock (fc:Hz)	1020000	1020000	1020000
	Code clock wave length(λc:m)	293.26	293.26	293.26
Transmission				
	Power (W)	18	18	18
	Antenna aperture (m)	2	1	1
	Antenna efficiency(η:%)	50	50	50
	Frequency(fc:MHz)	2660	2490	1600
	Antenna gain $G=10 \log(4\pi A_e/\lambda^2)$	31.9	25.32	21.45
	Feed loss	3	4	4
	E.I.R.P(dBw)	41.45	33.87	30
Propagation and Receiver				
	Distance	38000	38000	38000
	Propagation loss $L=-10\log(4\pi D/\lambda)^2$	192.52	191.96	188.1
	Rain loss (dB)	0.1	0.1	0.1
	Atmospheric loss (dB)	0.4	0.4	0.4
	Antenna aperture (m)	1	2	2
	Antenna efficiency(η:%)	50	50	50
	Antenna gain $G=10 \log(4\pi A_e/\lambda^2)$	25.88	31.34	3.14
	Feed loss	3	3	3
	Pointing loss	0.2	0.2	0.2
	System noise (T:K)	300	100	100
	Noise power ($P_n=KT$:dBw/Hz)	-203.83	-208.6	-208.6
	Signal power (dBw)	-128.7	-130.26	-134.12
	Loss due to calibration signal	5	5	5
	C/No	70.13	73.35	69.28
	BW=1 Hz, 1 sec clock phase precision (m) 3σ	0.274	0.189	0.302
	BW=1 Hz, 1 sec carrier phase precision (m) 3σ	0.000106	0.0000777	0.000194
	integration time (s)	60	60	60
	Clock phase precision (3σ:m) after integration	0.0354	0.0244	0.039
	Carrier phase precision (3σ:m) after integration	0.0000136	0.00001	0.000025

Questions and Answers

DAVID ALLAN (Allan's Time): Do you know the temperature coefficient for the ground equipment and for the satellite timing equipment?

MIZUHIKO HOSOKAWA (CRL): I am sorry, I am not sure about that coefficient.