

# TWO-WAY SATELLITE TIME TRANSFER (TWSTT) APPLICATIONS WITH THE EASTERN RANGE

I. Galysh, D. Koch, R. Beard  
U.S. Naval Research Laboratory  
4555 Overlook Ave., SW, Washington, DC 20375, USA

W. Reid  
SFA, Inc.

J. Buisson  
Antoine Enterprises

## Abstract

*The Eastern Range at Cape Canaveral, as part of the Range Modernization program, is incorporating Two-Way Satellite Time Transfer (TWSTT) systems into their stations. A detailed study of the mechanization of TWSTT into their systems had been performed and an experiment into different satellite links has been reported before. A design implementation has been completed. Acceptance testing was successfully performed at the Naval Research Laboratory (NRL), including over-the-air testing prior to the first installation at the Range Operation Control Center (ROCC), Cape Canaveral. The first phase of ROCC installation was completed in July 1998.*

*The results of acceptance testing at NRL indicated a sub-nanosecond time transfer capability. Data from those tests will be presented and discussed. Installation test data from the initial phase will be presented. Calibration of these units for absolute time comparison was difficult, but will support a nanosecond-level capability. The calibration methods and results will be described.*

## INTRODUCTION

The TWSTT System being installed at the Eastern Range will include its own time transfer network, where the Range Operations Control Center (ROCC) will be the master site and the down range sites will be targets. The network will operate in C-band using an Intelsat global transponder. The ROCC will also operate as a target site and perform time transfers with the DoD Master Clock at USNO over a Ku-band satellite link.

In April of 1998 a factory acceptance test was performed at NRL for the Air Force to demonstrate the operation and performance of the TWSTT modems. In July of 1998, the first phase of the network installation was completed by the installation of a TWSTT modem at the ROCC with a Ku-band Very Small Aperture Terminal (VSAT). A site acceptance test was performed and the equipment was accepted. The link to the DoD Master Clock was established. Operational time transfers began in November 1998.

## TWSTT CONFIGURATION AND OPERATION

Figure 1 shows a diagram of the hardware configuration of the TWSTT system. Each site within the TWSTT system contains a TWSTT Modem, and a VSAT coupled to a 1.4-meter parabolic antenna to

enable synchronization measurements via a leased geostationary communication satellite transponder. Two-way time transfer communications require approximately 4 MHz of transponder bandwidth and up to three time transfers can be performed in 30 minutes.

Two-way time transfer between two time standards is accomplished by having each of the standards send their 1 Pulse Per Second (1-PPS) signal to the other over a communications circuit. The TWSTT modem sends the 1-PPS using a Pseudo-Random Noise (PRN) code modulation. The transmission medium and the satellite electronics introduce delays, but by sending both directions the delays will be nearly reciprocal. Each site measures the time interval between the transmission of its local 1-PPS and the time it receives the remote site's 1-PPS signal. This exchange continues for 300 seconds to complete a time transfer. The time offsets of the two standards during the exchange can be measured very precisely (0.2 nanoseconds) and accurately (1.0 nanoseconds). By performing time transfers over a period of time, the long-term behavior of the time standard, i.e. frequency changes, rates, jumps, drifts, etc., that affect the accuracy and stability, and, thus, the operational usefulness of a clock may be accurately characterized. Improved confidence in decision making is a key benefit. The day-to-day stability of two-way time transfers can very nearly reach the performance of the best reference clocks.

There are two different satellite links to be used for the Eastern Range TWSTT System. The first link is between the DoD Master Clock and ROCC via G-STAR I in the Ku-band. The second link is between ROCC and the three downrange sites on an Intelsat satellite via a global coverage C-band transponder. The ROCC TWSTT system has a radio frequency switch to the antenna connections for selection between the Ku-band antenna and C-band antenna.

The configuration of the TWSTT modem has changed from that previously reported [1]. The TWSTT modem being deployed in this project is the fourth revision of the NRL-designed modem. Generation four of the TWSTT modem is a repackaging of generation three. The third generation TWSTT modem used previously consists of two Electronic Industries Association standard 19-inch rack-mountable chassis. One chassis contains the TWSTT Modem's computer, and the other contains the VSAT interface and the frequency source. The fourth generation computer chassis is now a single standard rack mount personal computer chassis with all connections in the rear, unlike the PCXI chassis previously used. This change was made because the PCXI chassis has been discontinued. The VSAT Interface has some circuit redesign to improve stability and reliability. More of the hardware is now digital. A color LCD display has been added to eliminate the need for an external monitor and a flip-up keyboard was also added.

The operating system is LINUX, using kernel version 2.0.34. This change was due to the need to update the CPU to Pentium II motherboards, since older motherboards are being phased out of production. The newest version of the operating system supports the newer motherboard chipsets. The TWSTT modem software has gone through maintenance updates and a few improvements. The user interface was updated to add keyboard control in addition to the mouse operations. These changes simplify the software installation. Originally the software was installed in the root directory and operated from there. The software was relocated to another directory and now allows multiple separate user accounts in operation of the TWSTT system.

## **FACTORY ACCEPTANCE TEST**

Before deployment and installation of the TWSTT system to the ROCC, an Acceptance Test was conducted at NRL. The Test was setup as shown in Figure 2. Both TWSTT systems were located at NRL and a Ku-band satellite link was used as the communication medium. The Time Interval Counter (TIC) between the

two frequency standards was used as the comparison reference. The performance was demonstrated during a ten-day test period where three time transfers were performed per day.

Thirty-two time transfer measurements were performed with three measurements per day, as shown in Figure 3. The extra two measurements were performed because of extra satellite time. Four significant outliers can be readily seen in the data, the largest being 18 milliseconds. These outliers have been attributed to transponder interference resulting from the user of the previous communication satellite time slot not completing transmission by the end of their assigned time slot. This type of interference can be operationally avoidable to prevent corruption of the time transfer measurements. The fourth outlier was one of the extra measurements performed. With the outliers and the other extra measurement taken deleted, the remaining 27 measurements were used to demonstrate performance. The phase offset between the two standards was determined with an RMS deviation about a linear least-squares fit to 2.6 nanoseconds. The offset of the two clocks determined by the TIC is shown for the same period in Figure 4. These measurements have an RMS deviation about linear least-squares fit of 3.0 nanoseconds. The larger difference in the TIC measurement has been attributed to the 100 sec averaging time for the counter providing a short-term measure on the HP 5071. Differencing the offsets between the two clocks provides a measure of the performance of the TWSTT and associated equipment and the result is shown in Figure 5. The data have an RMS deviation about a linear least-squares fit of 1.8 nanoseconds. Removal of one data point, from MJD 50927 which has a phase offset of 8 nanoseconds, would result in an RMS deviation of less than 1 nanosecond.

## CALIBRATION

An important element in the installation of the TWSTT system at the ROCC was the method to calibrate it for accurate over-the-air operation. Pre-calibration was not possible due to possible configuration differences at the installation site. The TWSTT modem was calibrated by taking a portable atomic clock, HP5071A Opt 001, to USNO and synchronizing it with the Master Clock. The time difference of the 1-PPS between the portable atomic clock and the Master Clock and drift were recorded along with the time of measurement. The portable atomic clock was then transported to the ROCC. After connecting the atomic clock 5 MHz and 1-PPS signals to the appropriate ports on the TWSTT modem, the modem was configured to operate as a target site. The time transfer tests performed during the site acceptance with TWSTT relative to USNO were performed using the portable atomic clock. The portable atomic clock was transported back to USNO after the site acceptance testing and the time difference between the atomic clock 1-PPS and the Master Clock 1-PPS was measured. By using the portable atomic clock as the reference at the ROCC the capability of the TWSTT link was compared to an independent precise clock synchronized to USNO. The resulting difference in time as measured at the ROCC and the portable clock was the composite uncalibrated delays in the TWSTT system. As a result the calibration factor was determined to be 81.3 nanoseconds.

## SITE ACCEPTANCE TEST

After the physical installation of the TWSTT equipment at the ROCC, an acceptance test was performed to verify the operational capabilities of the TWSTT system at the site. This includes interoperability with the facility, expected operating procedures, and system performance. The system performance portion of the acceptance test consisted of three time transfers at Ku-band twice per day for five days. Each time transfer consisted of 300 one-second measurements. Three time transfers were taken during a half-hour period. Figure 6 shows the equipment configuration. Simultaneously measurements were made using a keyed GPS

receiver at the ROCC operating on a common-view time transfer schedule with USNO. The portable clock discussed above was also used as the local clock for the GPS common-view measurements.

Thirty-one TWSTT measurements were made over a period of eight days and are presented in Figure 7. The measurements plotted show phase offsets between the two clocks of -170.7 nanoseconds at the midpoint of the data interval. These measurements are shown in Figure 8 to have an RMS deviation about a linear least squares fit of 1.2 nanoseconds.

The phase and frequency offset of the two clocks determined by GPS receiver are shown in Figure 9 to be -80.1 nanoseconds and  $-8.7 \text{ pp } 10^{14}$  at the midpoint of the data interval. These measurements are shown in Figure 10 to have an RMS deviation about a linear least squares fit of 10.2 nanoseconds. This less precise result was expected; however, the results confirm the range and trend of the TWSTT data. The phase and frequency offsets between the portable atomic clock and the DoD Master Clock before and after the acceptance test period can be seen from Figure 11 to be -89.4 nanoseconds. Although the data from the portable clock is not continuous and limited, it was believed that based on the performance of the HP 5071 that interpolation between the data points was a reasonable method of estimating performance during the test.

In Figure 12, the data from the three time comparison methods between the ground reference clock at the ROCC from the DoD Master Clock are shown relative to each other. The TWSTT and the portable clock measurements were differenced to obtain the calibration of the TWSTT and the associated equipment. The result of adding the calibration factor of 81.3 nanoseconds to the TWSTT measurements is shown in Figure 13, where it can now be seen that the TWSTT measurements closely agree with the portable clock measurements.

## CONCLUSIONS

The factory acceptance test results performed at NRL had overall phase offset variations of up to 7 nanoseconds, but the individual time transfer sessions demonstrated sub-nanosecond phase offset performance on a day-to-day basis when compared with the TIC as seen in Figure 5. The technique of performing three consecutive time transfers for a half-hour measurement session was confirmed as a good operational practice, as witnessed during the first half of this test. The satellite interference observed during the factory test never lasted for the entire 30 minutes of test time and, thus, gave an indication of the quality of the time transfer session.

The site acceptance test results demonstrated overall phase offset variations of up to 6 nanoseconds, but once again the individual time transfer sessions demonstrated sub-nanosecond phase offset on a day-to-day basis. Performing the portable clock trip for calibration was the best method for this site because of the dynamic configurations that were occurring at the time. This site acceptance test would have benefited from more portable clock measurements during the test period, but this was not logistically possible at the time. The small difference in the slope or frequency offset may be attributed to the uncertainty in the portable clock measurements. With multiple portable clock measurements the RMS deviation and resulting uncertainty could be better determined.

Overall the results were quite satisfactory. The methods and techniques used in these tests will form the basis of further testing and calibration in the extension of the TWSTT network to the down range stations of the Eastern Range.

## REFERENCES

1. I. J. Gaylsh, D. M. Craig, W. Reid, and J. A. Buisson "*Performance Analysis of the GPS Monitor Station Subsystem Enhancement Program at the Naval Research Laboratory,*" Proceedings of the 1996 Annual Precise Time and Time Interval (PTTI) Applications and Planning Meeting, 3-5 December 1996, Reston, Virginia, U.S.A., pp,417-428.

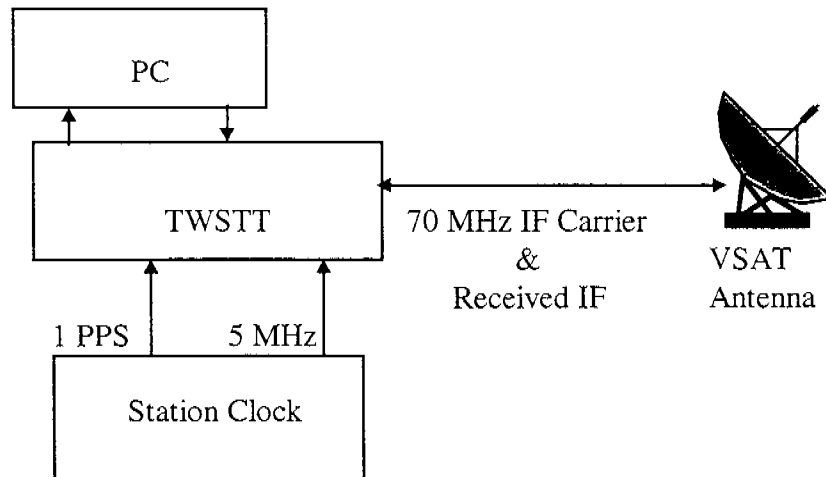

Figure 1. TWSTT Hardware Block Diagram

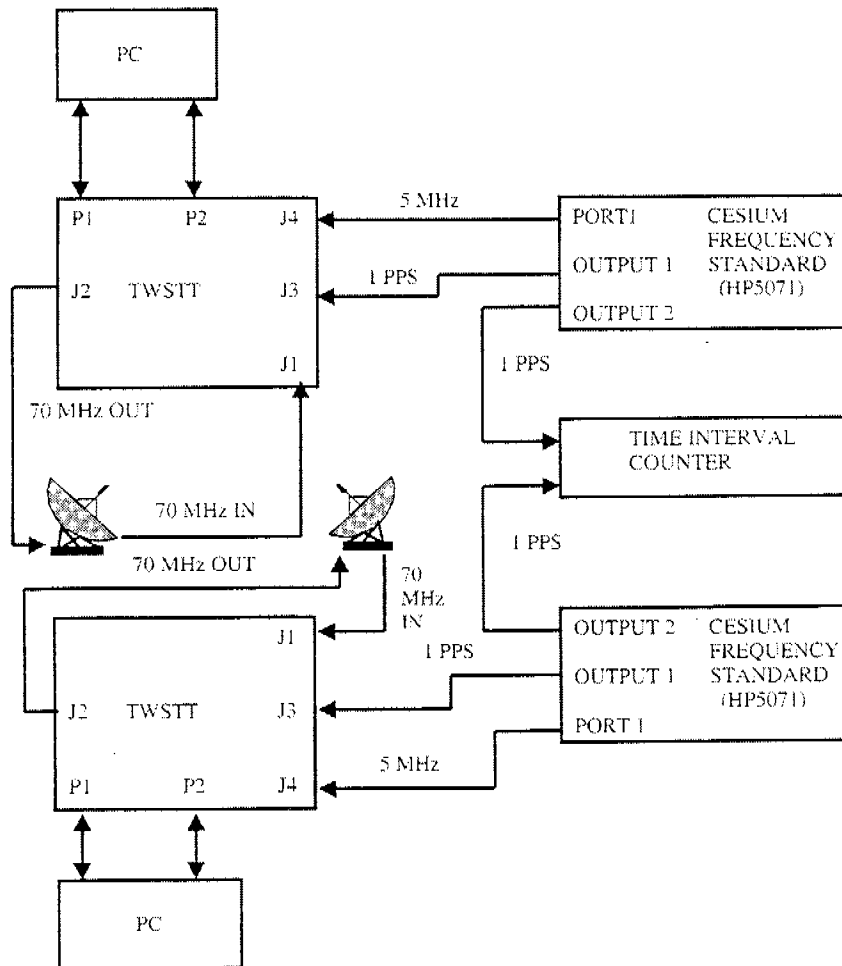

Figure 2. Factory Acceptance Test Hardware Block Diagram

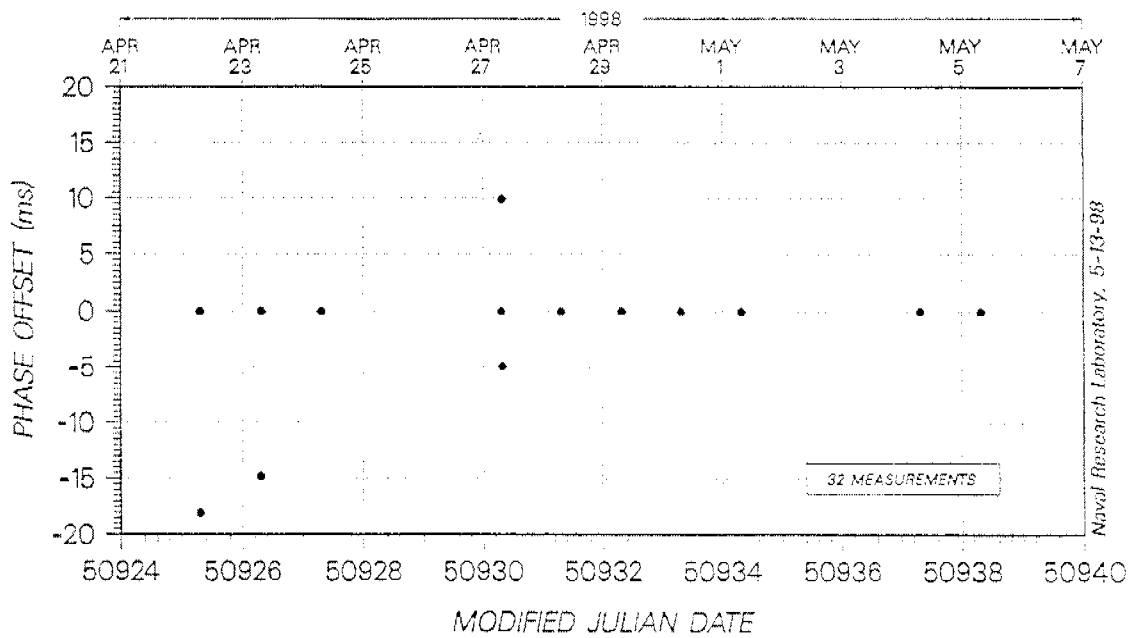

Figure 3. Factory Acceptance Test Results

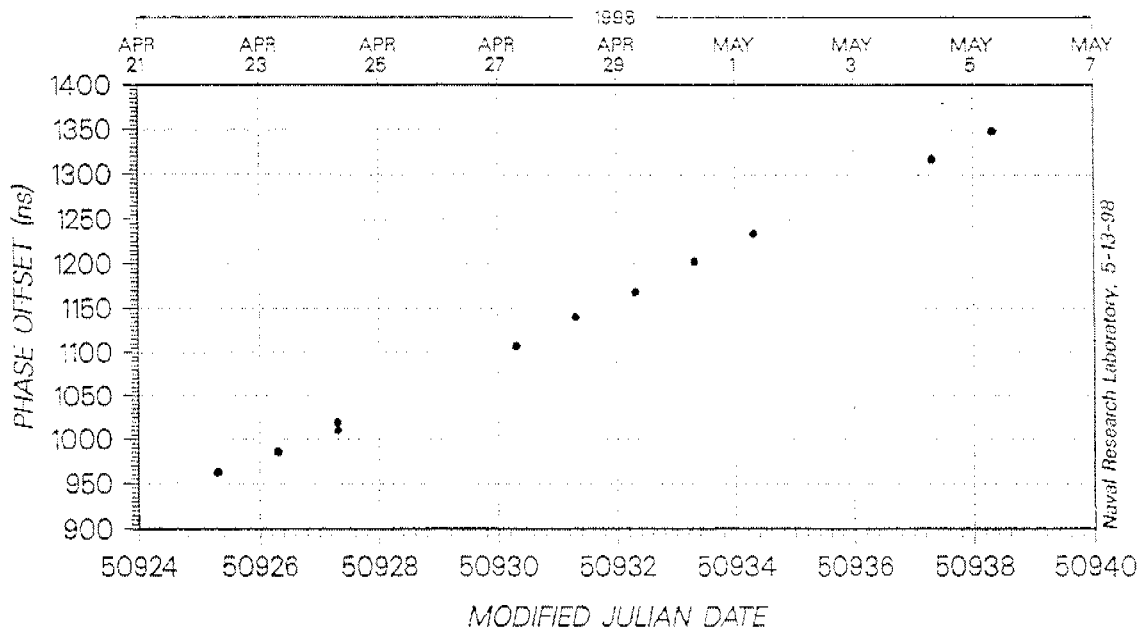

Figure 4. Factory Acceptance Test TIC Measurements

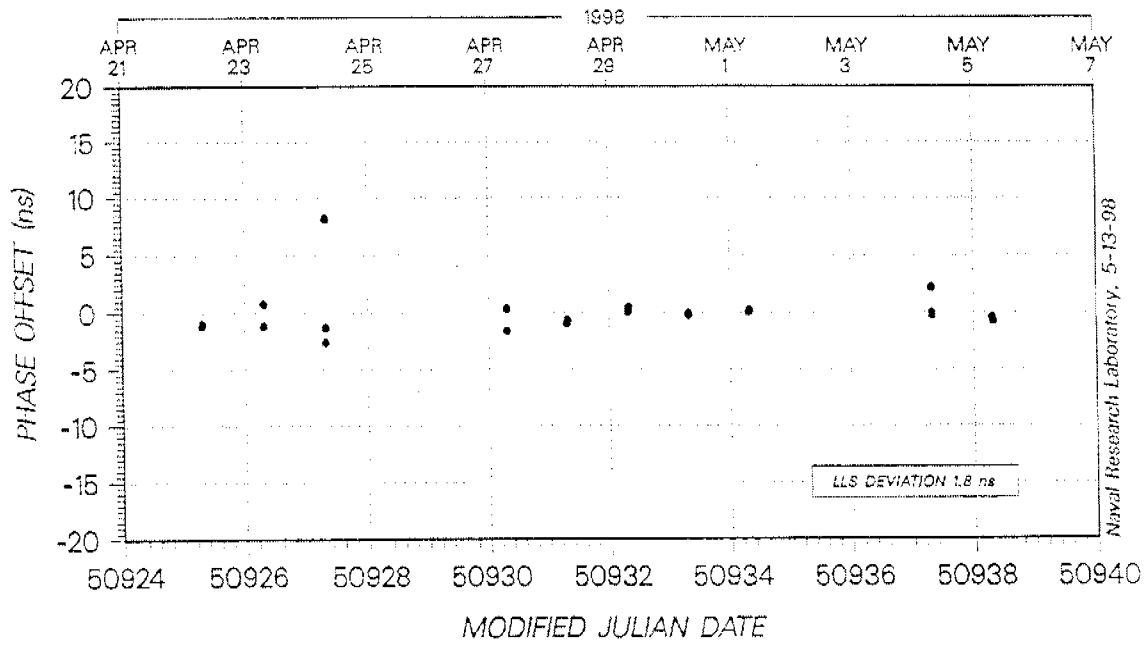

Figure 5. Factory Acceptance Test (TWSTT - TIC) Measurements

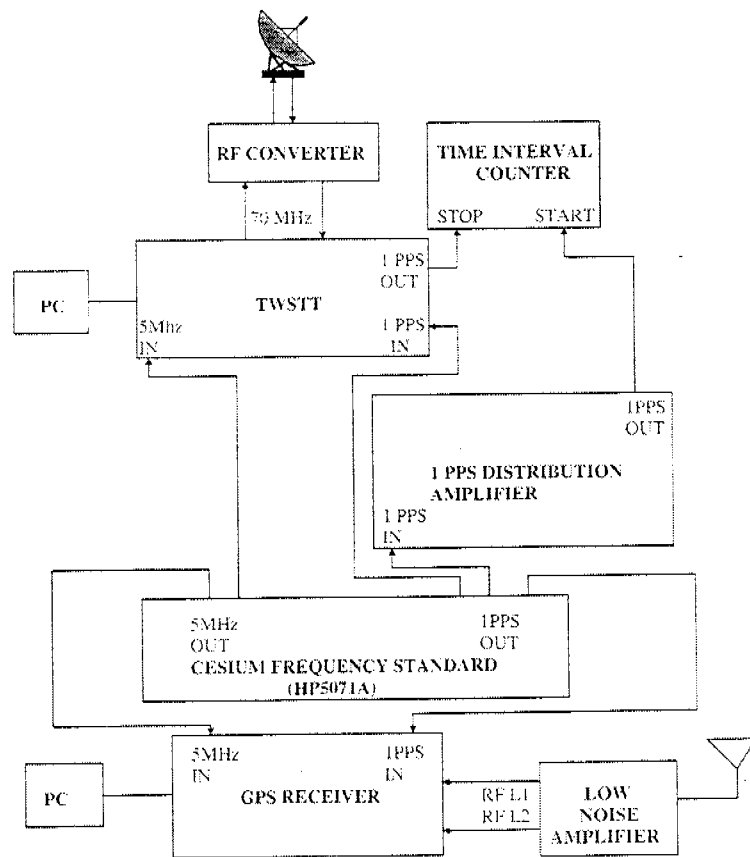

Figure 6. Site Acceptance Test Hardware Block Diagram



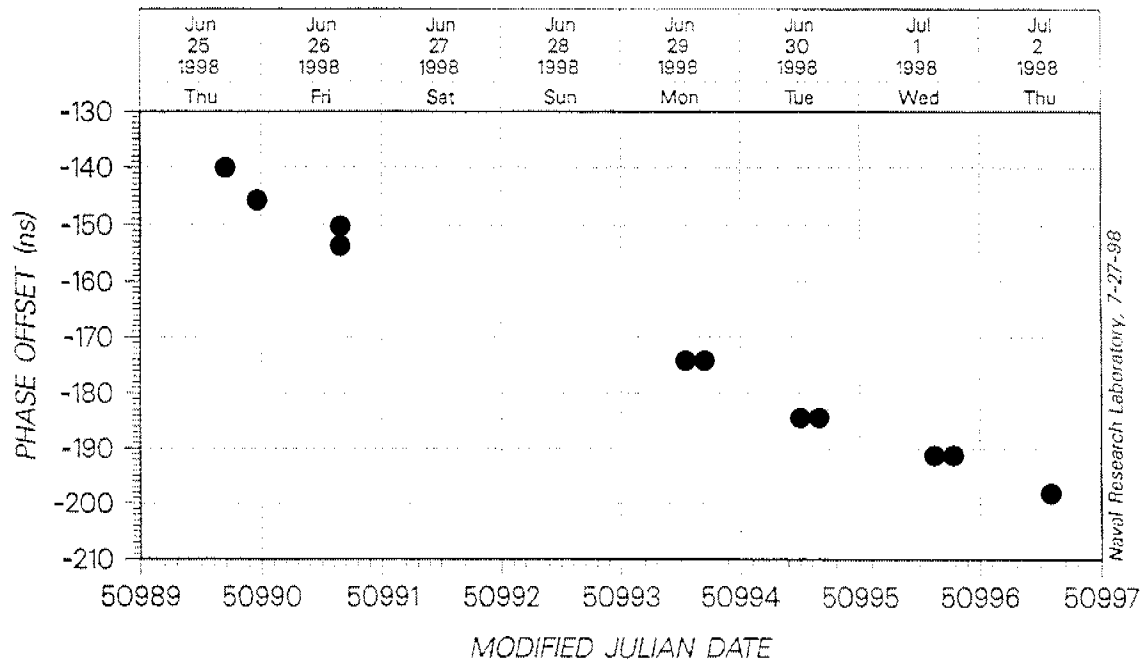

Figure 7. Site Acceptance Test Results

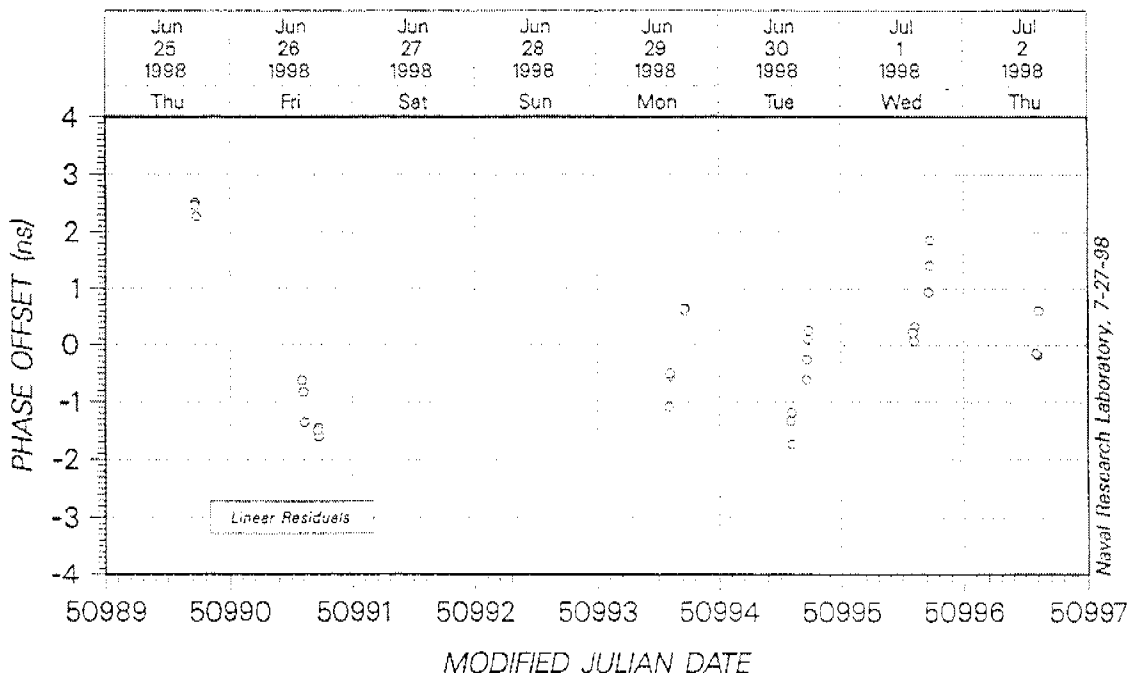

Figure 8. Linear Residuals of Site Acceptance Test Measurements

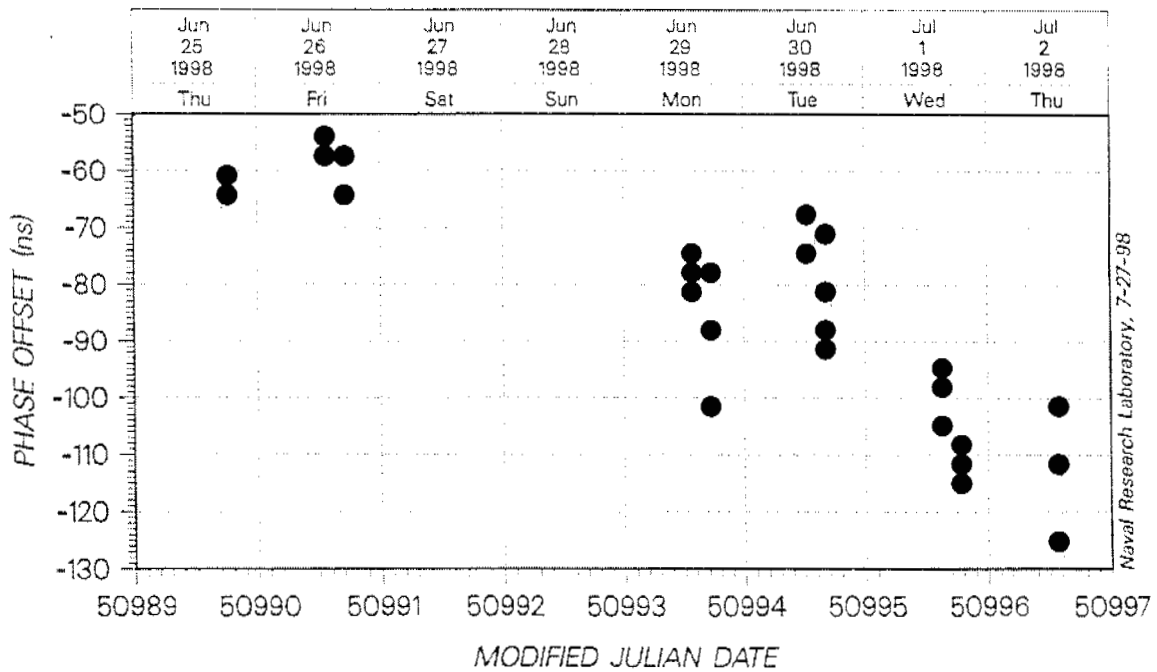

Figure 9. Site Acceptance Test Comparison Results by GPS Common View

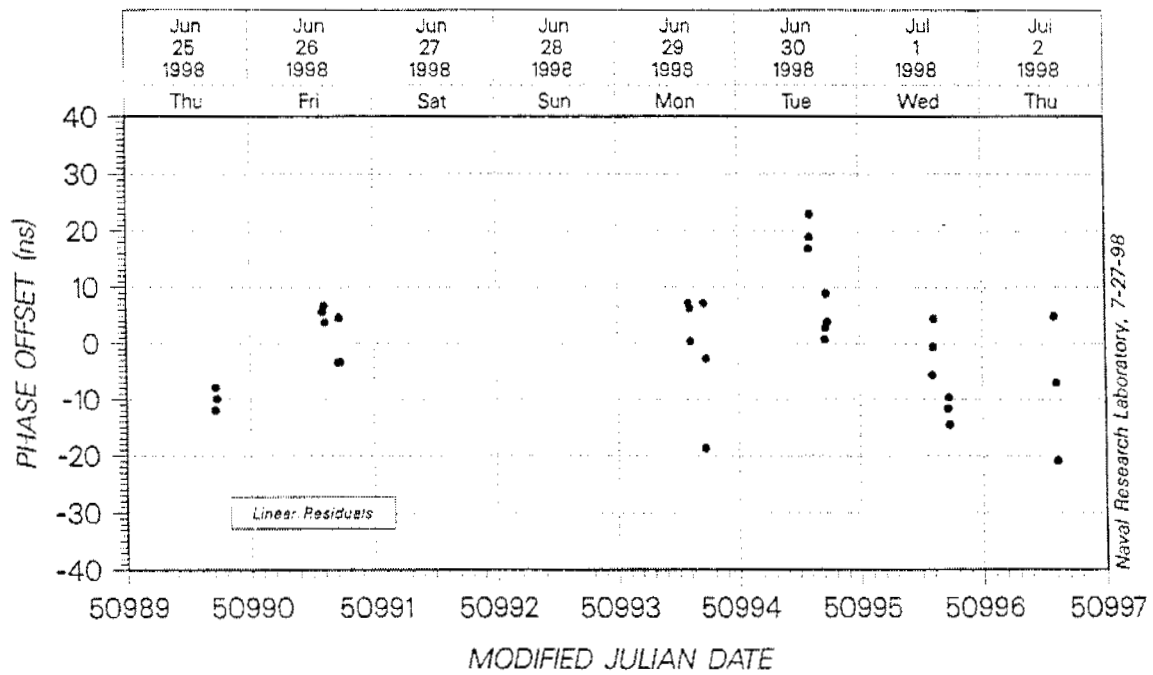

Figure 10. Linear Residuals for Site Acceptance Test GPS Common View

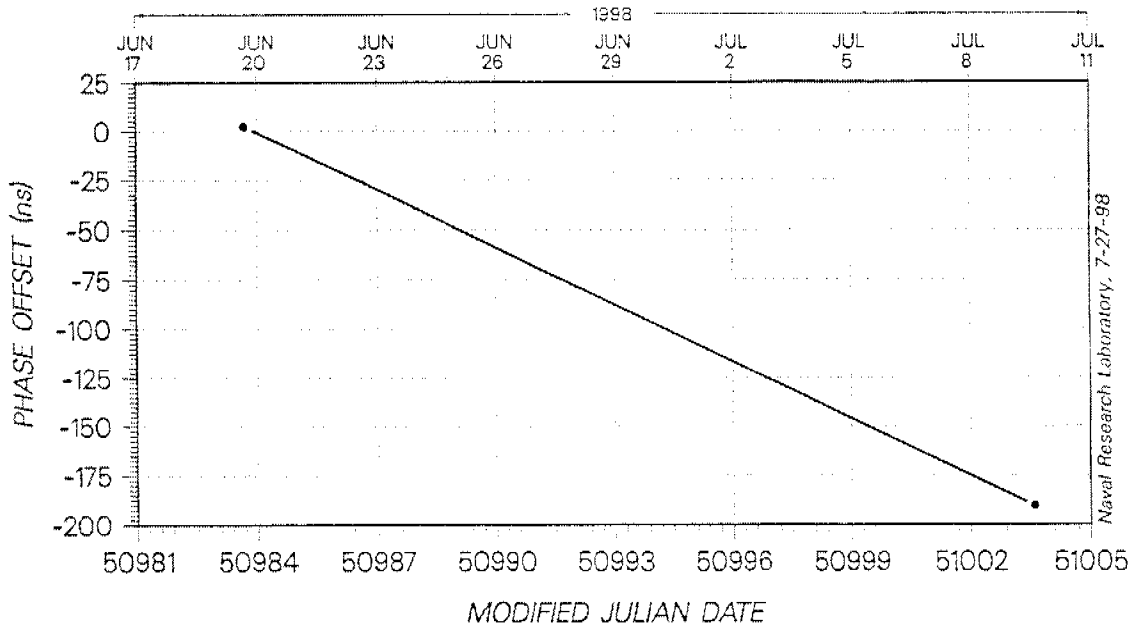

Figure 11. Site Acceptance Test Portable Clock Comparison

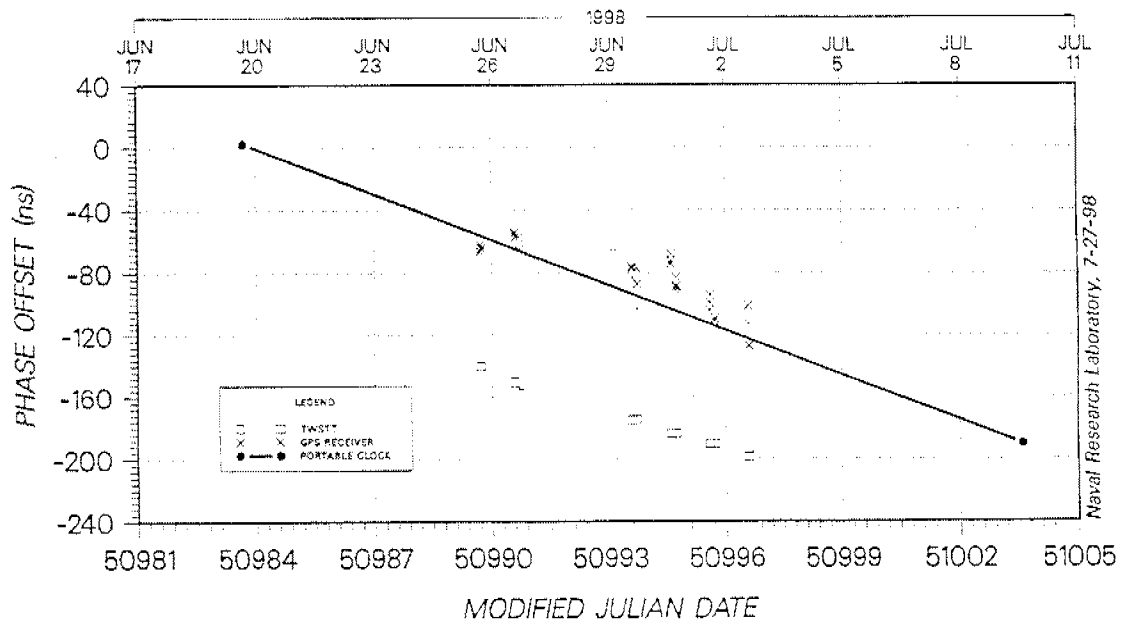

Figure 12. Site Acceptance Test Combined Results of Time Transfer Methods

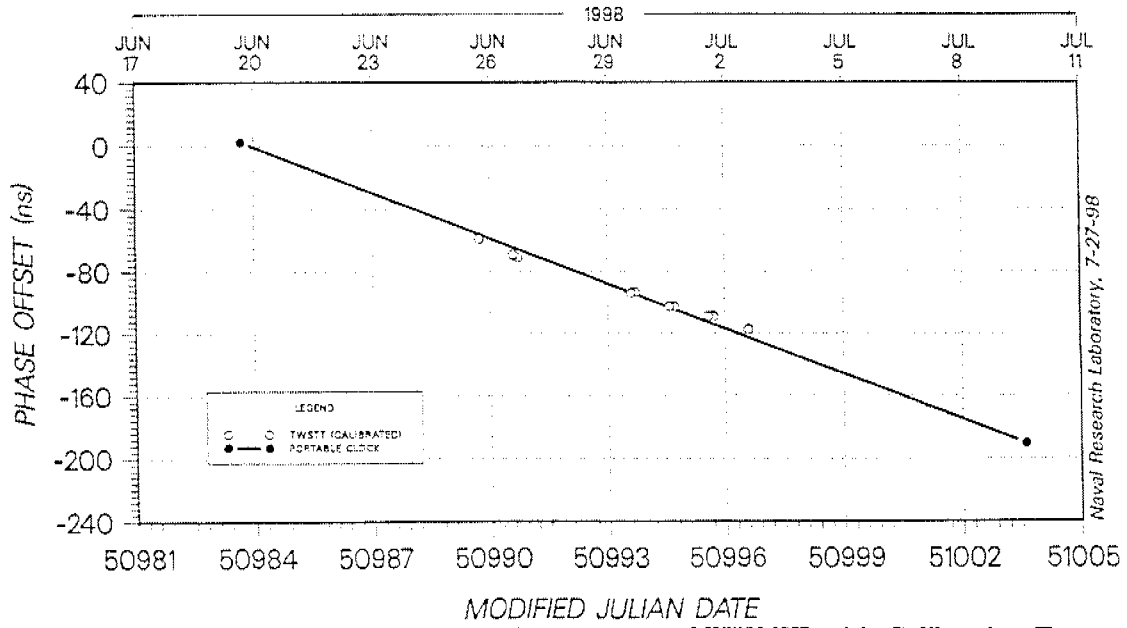

Figure 13. Site Acceptance Test Comparison of TWSTT with Calibration Factor

## Questions and Answers

JIM DeYOUNG (USNO): Are there any plans for ongoing or continuous monitoring of the calibration to see how it is going to change over time? Or is this just going to be a one-shot calibration?

DOUGLAS KOCH (NRL): I guess they will look at the data, but this is a one-shot calibration for this initial installation. They follow one installation at the down range sites; each one will be calibrated very much the same way.

MIHRAN MIRANIAN (USNO): I know what GPS receiver you use, and that has a notoriously bad time-interval counter built into it. That is probably why you got your 10 nanoseconds --. If you use an external counter, you could probably do a lot better than that.