

MILLISECOND PULSAR OBSERVATION AT CRL

Y. Hanado, M. Imae, M. Hosokawa, M. Sekido, A. Kaneko and Y. Shibuya
Communications Research Laboratory
4-2-1, Nukui-kitamachi, Koganei, Tokyo 184 JAPAN

Abstract

Communications Research Laboratory (CRL) has developed a millisecond pulsar observation system which uses an acousto-optic spectrometer (AOS). Even though our 34 m telescope is one of the smallest telescopes used for millisecond pulsar observations, we succeeded in detecting several millisecond pulsars by using our new system which has a wide detection bandwidth. We started regular observations of PSR1937+21 with the 34 m telescope one year ago. The observed pulse phases contain some systematic trends, and we are investigating the data now. We also tested our observation system at the Usuda 64 m telescope of Institute of Space and Astronautical Science (ISAS) and succeeded in detecting two other highly stable millisecond pulsars, PSR1713+07 and PSR1855+09.

INTRODUCTION

Millisecond pulsars which have a millisecond pulse rate, are known to maintain extremely stable pulse timings over a long period of time. For the millisecond pulsar PSR1855+09 with a 5.36 ms pulse period, the fractional frequency stability was reported to be on the order of 10^{-14} over a period of 7 years[1], which is comparable to that of a cesium clock. These characteristics are expected to lead to millisecond pulsars being used in time-keeping metrology, planetary ephemerides, reference frame ties, and so on[2].

Communications Research Laboratory (CRL) serves as the national institute of time and frequency standards in Japan, and we plan to use millisecond pulsars in setting these frequency standards in the long term. We had to develop a highly sensitive observation system because our 34 m telescope at Kashima Space Research Center is not so large for millisecond pulsars that have very weak signals. In 1992, we developed a preliminary filter bank system with 4 MHz detection bandwidth and succeeded in detecting PSR1937+21 [3], which is the brightest millisecond pulsar in the northern sky. Based on this result, we developed an even more sensitive system last year. This system uses an acousto-optic spectrometer (AOS) [4] instead of filter banks, and detection bandwidth of 200 MHz is available. Using this system and 34 m telescope, we started weekly observations of PSR1937+21 in November 1997. Data analysis and system performance checks are now in progress.

We also tested this observation system at the Usuda 64 m telescope of the Institute of Space and Astronautical Science (ISAS), and succeeded in detecting two other weak and highly stable millisecond pulsars, PSR1855+09 and PSR1713+07. The detection of PSR1713+07 was confirmed with the Kashima 34 m telescope.

This paper introduces our new observation system, and presents observations results for PSR1937+21 over a one-year period. The results of preliminary observation for PSR1855+09 and PSR1713+07 at Usuda 64 m telescope are also reported.

OBSERVATION SYSTEM

1. CONCEPT OF SYSTEM DESIGN

In pulsar observation, the precision of pulse arrival time is estimated as follows;

$$\sigma_{\text{rms}}(\text{s}) \sim \frac{(W)^{3/2} \cdot T_{\text{sys}}}{(B t P)^{1/2} \cdot \langle S \rangle \cdot G}, \quad (1)$$

where W is the half-width of the pulse in seconds, P is the pulse period in seconds, T_{sys} is the system temperature on the source, $\langle S \rangle$ is the flux density in janskys (Jy), G is the telescope gain in kelvins per jansky (K/Jy), B is the bandwidth in Hz, and t is the integration time in seconds [5]. Because millisecond pulsar signals are very weak, big telescopes such as the 300 m one at Arecibo are usually used for observing their timings. Our 34 m telescope is very small for millisecond pulsar observation and required a system with wide detection bandwidth B and long integration time T .

For a wide-band observation, however, we must note the pulse broadening caused by the dispersion effect caused by interstellar plasma (Fig. 1(a)). In order to suppress this broadening, a wide-band signal must be received as many narrow channels at first and combined after each dispersion delay has been cancelled (Fig. 1(b)). In our new system an acousto-optic spectrometer (AOS) is used for this spectrum analysis instead of a filterbank method. The AOS uses an acousto-optic device such as a single crystal of TeO_2 (Fig. 2). It makes the system simple and compact.

The long integration time is achieved by accumulating many pulses. We developed a high-speed averaging processor which can average up to 2^{24} pulses without any dead time for data transportation. It supplies the averaged data almost in real time.

2. SYSTEM DESCRIPTION

The 34 m telescope has several receivers from 1.5 GHz to 43 GHz with a selective polarizer; we mainly used the right-hand circular polarization in 2 GHz band. An IF signal with 200 MHz bandwidth is divided into four 50 MHz units by the video converter. Each 50 MHz bandwidth unit is divided into 256 200-kHz channels by the AOS, then serially transported to the video averaging processor. This transportation time, which limits the time resolution is at least $12.8 \mu\text{s}$ ($= 50 \text{ ns} \times 256 \text{ ch}$) in minimum. Because the

transportation trigger clock is set to 1/100 of the pulsar period, the time resolution is about 16 μ s for PSR1937+21. The video averaging processor works as an 8 bits A/D converter and an averager which allows the addition of 2^{24} pulses (= 7 hours' integration for PSR1937+21) in each channel. At host#1, averaged data for all the channels are combined after a dispersion delay calibration carried out in 1/1000 steps of the pulsar period, and the final pulse profile is defined. From this profile, the peak phase is defined as the arrival pulse timing.

Host#2 calculates the predicted pulse period and supplies it in real time to the synthesizer, which controls the averaging trigger clock of the timing signal generator. This predicted value is obtained from the database calculated by the Tempo program, which is the Princeton pulsar timing analysis package [5]. The reference clock is synchronized with UTC. The observation start time is obtained at a time interval counter by measuring the time difference between the start trigger signal and 1PPS signal of UTC.

OBSERVATION RESULTS

1. PSR1937+21 AT KASHIMA 34 M TELESCOPE

We have been making the weekly observations of PSR1937+21 in the 2 GHz band since November 1997. PSR1937+21 is one of the brightest millisecond pulsars; its flux density is about 3.3 mJy in the 2 GHz band (calculated from [6]) and the pulse period is about 1.5578 ms. One pulse profile is obtained after averaging 1,048,576 pulses (corresponding to about 27 minutes of integration), and 6-8 profiles are obtained in one day. The averaged profile is shown in Fig. 5. From these averaged profiles the peak phases are defined, and their residuals from the predicted phases show the pulse timing noise. Residual $R(t)$ is calculated as

$$R(t) = \phi \text{ obs}(t) - \phi \text{ calc}(t), \quad (2)$$

where $\phi \text{ obs}(t)$ is an observed peak phase, and $\phi \text{ calc}(t)$ is the predicted phase calculated by the Tempo program.

Figure 6 shows the $R(t)$ s from Nov. 21, 1997 - Oct. 9, 1998 and Fig. 7 shows the $R(t)$ s in each day. This result is made from only the AOS#1 unit for 2150 - 2200 MHz, because other units were out of order during some observation periods. The systematic trend is shown in the long term, and linear trends are shown over a day. These are probably due to an error in the predicted pulse phases or some hardware problems; we are making efforts to eliminate these causes.

In order to estimate the observation precision in hardware, we removed the trends in each day by linear fitting (shown by the solid line in Fig. 7). The standard deviation for all data was 5.4 μ s after the fitting, which is comparable to the expected observation precision of 3.2 μ s calculated by Equation 1 with $W = 80 \mu$ s, $\langle S \rangle$ at 2.2GHz = 3.3 mJy, $P = 1.5578$ ms, $T_{\text{sys}} = 71$ K, $G = 0.426$ K/Jy, $B = 50$ MHz, and $T = 1632$ s.

2. PSR1855+09 AND PSR1713+07 AT 64 M TELESCOPE

We carried out a test observation with our new system at the Usuda 64 m telescope. This telescope belongs to the Usuda Deep Space Center of ISAS, and is mainly used for deep space satellite tracking. The system noise temperature is 40 K and the efficiency is 70 % in the 2GHz band. We tried to observe the millisecond pulsars PSR1855+09, which has a 5.36 ms pulse period, and PSR1713+07, which has a 4.57 ms pulse period [7]. Both are weaker than PSR1937+21, but are expected to be more stable.

Figure 8 shows the averaged profiles of PSR1855+09 and PSR1713+07. The observation band was 2275 – 2305 MHz in right-hand circular polarization, and one AOS unit is enough to cover it. Averaging pulses were 131,072 for PSR1855+09 and 262,144 for PSR1713+07, which correspond to the integration of 12 minutes and 20 minutes respectively.

For PSR1713+07, we succeeded in detecting the pulse at the Kashima 34 m telescope afterward. Regular observation of PSR1713+07 at Kashima will start soon.

CONCLUSIONS

We developed a new millisecond pulsar timing observation system for our 34 m telescope at Kashima. This system uses an AOS as a spectral divider instead of filter banks, and we can detect a signal up to 200 MHz bandwidth. We confirmed its performance by detecting PSR1937+21 and PSR1713+07 with the 34 m telescope and PSR1855+09 with the 64 m telescope at Usuda. Using this system, we started weekly observation of PSR1937+21 at Kashima, but the results must be considered carefully because observed peak phases show some systematic trends both in the long term and during one day. Perhaps we misuse the Tempo program; we are now investigating the predicted pulse phases by simulation.

We started VLBI observation for pulsars using the Kashima 34 m telescope and the Kalyazin 64 m telescope in Russia[8]. We intend to contribute to a new reference frame for data of both pulsar timing and VLBI in future.

ACKNOWLEDGMENTS

The authors gratefully thank Dr. H. Kobayashi and Dr. K. Fujisawa in the ISAS and Dr. N. Kawaguchi in the National Astronomical Observatory for their support of the observation at Usuda Deep Space Center, and Dr. M. Bailes at the University of Melbourne for kind advice about the Tempo program.

REFERENCES

- [1] V. H. Kaspi, J. H. Taylor, and M. F. Ryba, "High-precision timing of millisecond pulsars. III. Long-term monitoring of PSRs B1855+09 and B1937+21," *Astrophys. J.*, 428, 713-728, 1994.
- [2] A.S. Fruchter, M.Tavani, and D.C. Backer, "Millisecond pulsars: A decade of surprise," *Astronomical Society of the Pacific conference series vol.72*, pp. 345-356.

- [3] Y. Hanado, H. Kiuchi, S. Hama, A. Kaneko, and M. Imae, "Millisecond pulsar observation system at CRL," Proceedings of 23rd Annual Precise Time and Time Interval (PTTI) Application and Planning Meeting, 1991, pp.377-383.
- [4] A. P. Goutzoulis and I. J. Abramovitz, "Digital electronics meets its match," IEEE Spectrum, 21-25, August 1988.
- [5] R. S. Foster and D. C. Backer, "Constructing a pulsar timing array," Astrophys.J., 361, 300 - 308, 1990.
- [6] R. S. Foster, L. Fairhead, and D. C. Backer, "A spectral study of four millisecond pulsars," Astrophys. J., 378, 687-695, 1991.
- [7] R. S. Foster, A. Wolszczan, and F. Camilo, "A new binary millisecond pulsar," Astrophys. J., 410, L91-L94, 1993.
- [8] M. Sekido, M. Imae, Y. Hanado, Y. Takahashi, Y. Koyama, Y. P. Ilyasov, A. E. Rodin, A. E. Avramenko, V. V. Oreshko, and B. A. Poperechenko, "Pulsar VLBI Experiment with Kashima(Japan)-Kalyazin(Russia) Baseline," A.S.P.Conf.Ser.Vol.105, Proceedings of IAU Colloquium 160 Pulsars: Problems and Progress, pp.117-118, 1996.

Table 1. Specifications

Telescope at Kashima	
Diameter	34 m
Observation frequency	2120 - 2320 MHz
System noise temperature	71 K
Efficiency	65 %
Receiving system	
Total bandwidth	200 MHz (50 MHz x 4 units)
Frequency resolution	~ 200kHz
Time resolution	16 μ s
Number of pulse accumulated	$2^0 - 2^{24}$

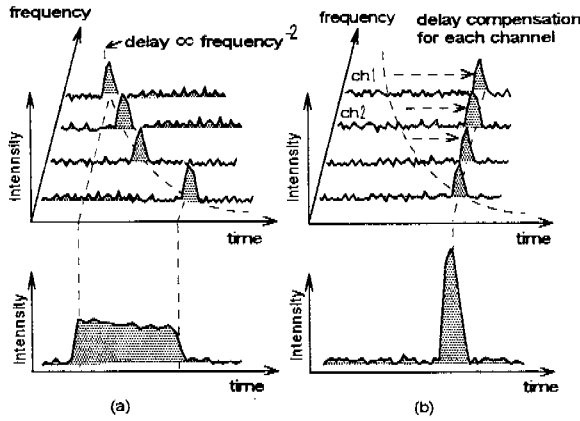

Figure 1. Dispersion effect.

- (a) Pulse broadening by dispersion effect for wide band observation.
- (b) De-dispersion processing.

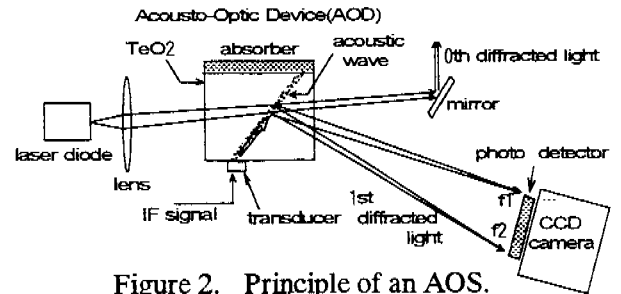

Figure 2. Principle of an AOS.

An electrical input signal is transformed by a transducer into an acoustic wave, which acts as a grating in the acousto-optic device and diffracts an incident laser beam by an angle proportional to the frequency of the electrical input. The first-order diffracted lights are focused onto the photo-detectors of a CCD camera, where they are reconverted into the electrical signals. The intensity of the diffracted light is proportional to the intensity of the electrical input.

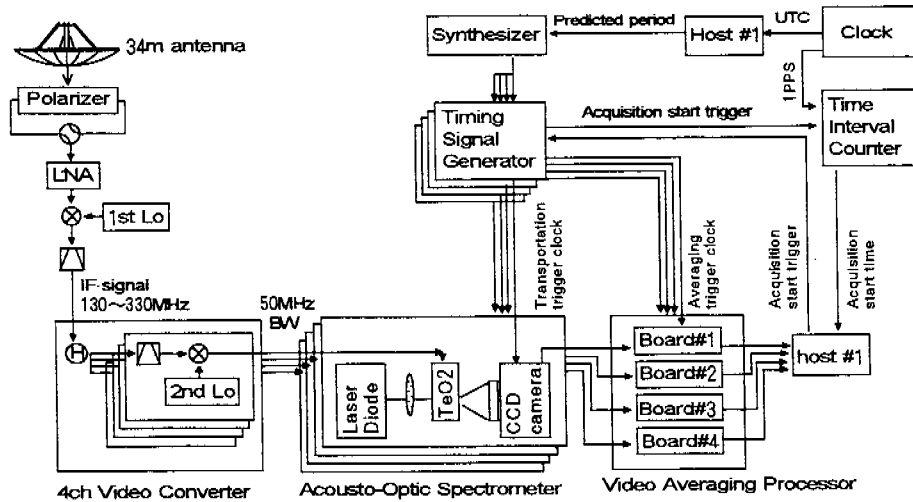

Figure 3. Observation system at CRL

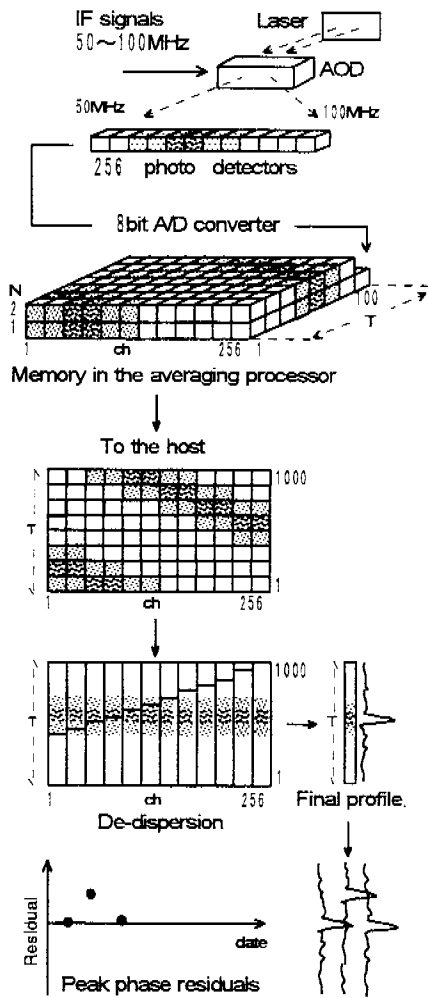

Figure 4. Data flow.

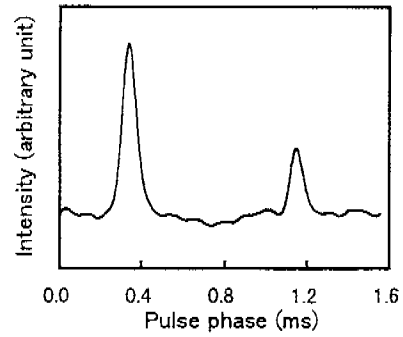

Figure 5. PSR1937+21 profile at Kashima. Observation bandwidth is 50MHz at 2GHz and integration time is 27 minutes.

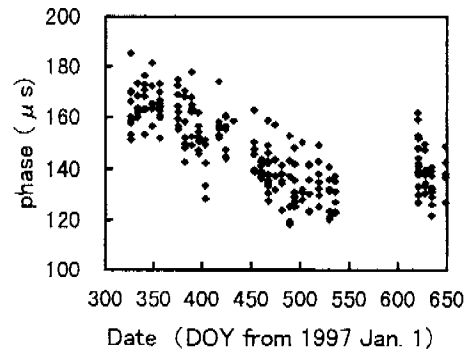

Figure 6. Timing residuals of PSR1937+21. (Nov. 21,1997~Oct. 9,1998)

Predicted phases are calculated by Tempo program ver. 10.010. Each observed phase is obtained from the observations with 50MHzBW in the 2GHz and 27 minutes integration.

[μ s]

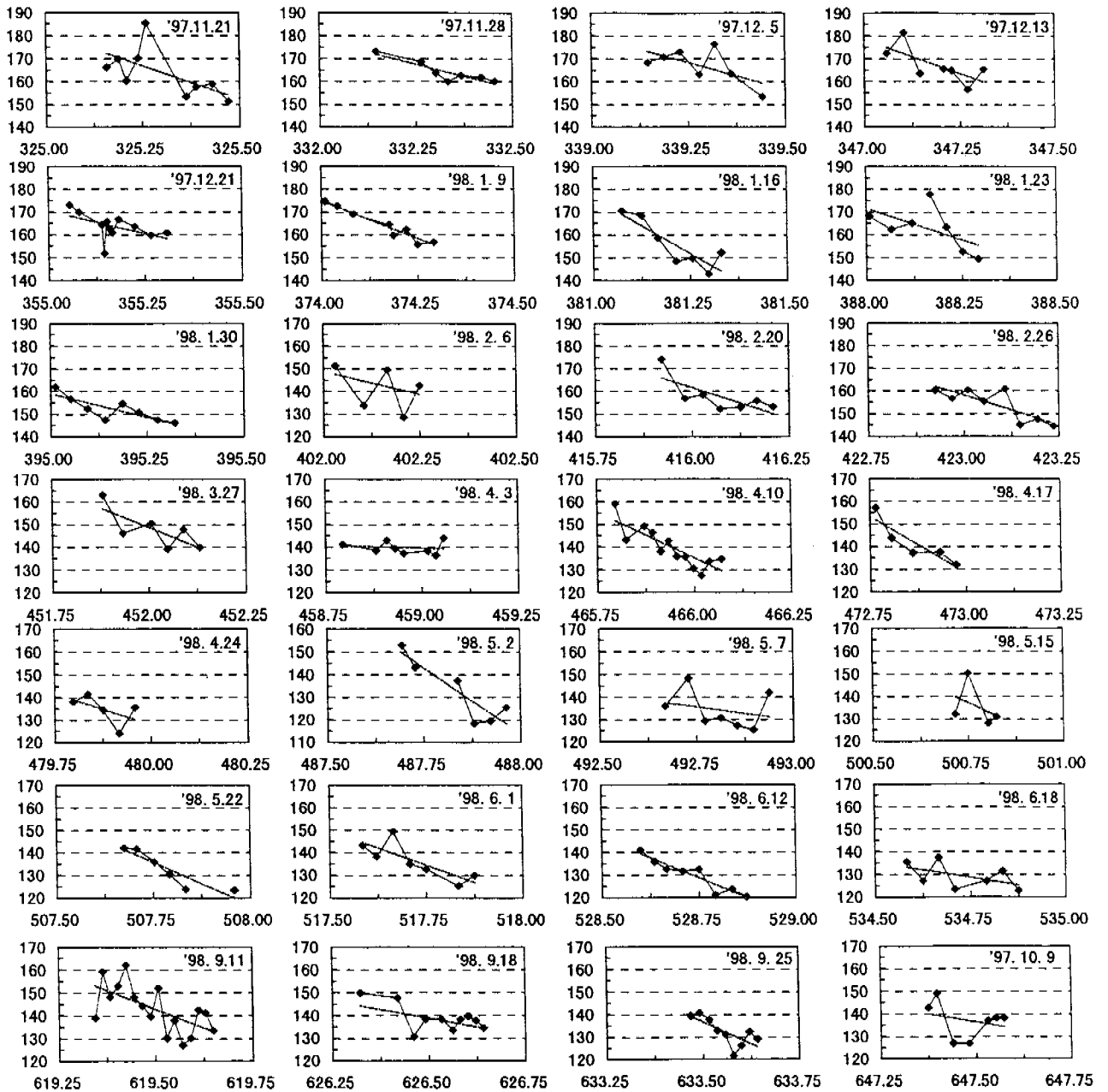

Figure 7. Timing residuals of each observation day for PSR1937+21. The standard deviation of all data is 5.4 micro second after the linear fitting (shown by the straight line in each day)

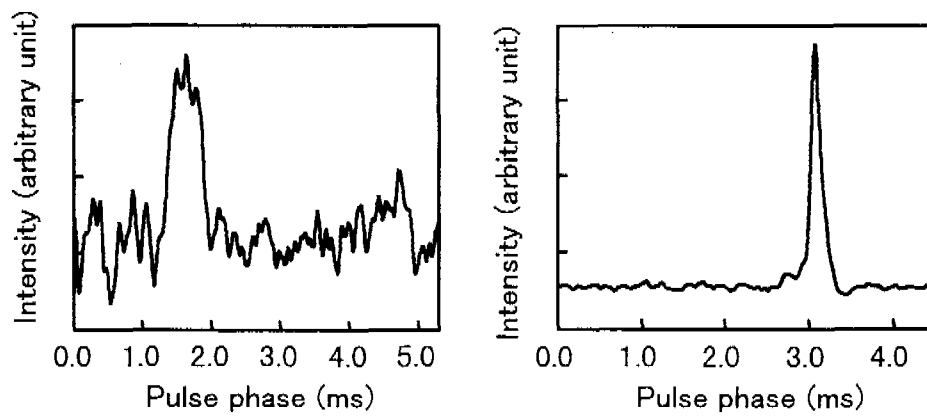

Figure 8. Pulse profile of PSR1855+09 and PSR 1713+07 at Usuda 64m antenna. Observation frequency is 2275-2305MHz. (a) PSR1855+09: Pulse period is 5.36ms, Flux density at 2GHz band is about 2mJy. Integration time is about 12 minutes. (b) PSR1713+07: Pulse period is 4.57ms, Flux density at 2GHz band is about 4mJy. Integration time is about 20 minutes.