

# **RESULTS OF THE CALIBRATION OF THE DELAYS OF EARTH STATIONS FOR TWSTFT USING THE VSL SATELLITE SIMULATOR METHOD**

**Gerrit de Jong**  
NMI Van Swinden Laboratorium, P.O. Box 654,  
2600 AR Delft, the Netherlands

**Dieter Kirchner**  
Technical University Graz, Graz, Austria

**H. Ressler**  
Space Research Institute, Graz, Austria

**Peter Hetzel**  
Physikalisch Technische Bundesanstalt, Braunschweig, Germany

**John Davis, Peter Pears**  
National Physical Laboratory, Teddington, UK

**Bill Powell, Angela Davis McKinley, Bill Klepczynski, James DeYoung**  
U.S. Naval Observatory, Washington, D.C. 20392, USA

**Christine Hackman, Steve R. Jefferts, and Thomas E. Parker**  
National Institute of Science and Technology,  
Boulder, Colorado 80303, USA

## **INTRODUCTION**

Two-Way Satellite Time and Frequency Transfer (TWSTFT) is the most accurate and precise method of comparing two remote clocks or time scales. The accuracy obtained is dependent on the accuracy of the determination of the non-reciprocal delays of the transmit and the receive paths. When the same transponders in the satellite at the same frequencies are used, then the non-reciprocity in the Earth stations is the limiting factor for absolute time transfer.

In each Earth station, the clock signal (1 pulse per second = 1PPS) is modulated on an IF

carrier frequency, then up-converted to the transmit up-link frequency, amplified by a high-power amplifier (HPA), and radiated to the satellite by the antenna. The signal from the companion station clock is received at the satellite down-link frequency by the same antenna, amplified by a low-noise amplifier (LNA), and then down-converted to the IF frequency and demodulated to the received clock signal.

The cables used in the station in the transmit path may differ from the cables in the receive part; the filter and tuned circuit delays may differ as well. The stability of these delays may also be affected by difference in temperature coefficients, temperature gradients, and thermal time constants; these limit the frequency transfer capability of TWSTFT.

During September, October, and December 1994, six Earth stations participating in a TWSTFT experiment on the INTELSAT satellite at 307°East were calibrated in an absolute way using the NMI-VSL Satellite Simulator method. They were also calibrated in a relative way by a visiting small USNO Earth station called Fly Away Satellite Terminal (FAST). Calibration results and the difference with preliminary FAST co-location results are presented.

## METHOD

The results at several Earth stations are obtained with the method and instrumentation developed at the NMI Van Swinden Laboratorium using a special satellite simulator (Figs. 1 and 2) to determine the differences of the transmit and receive delays from absolute measurements. The principle of this method has been described earlier<sup>[4,1]</sup>. We have separated the determination of the delay inside the modem from the delays external to the modem (Fig. 3). Firstly, the sum of the receive (RX) delay and a calibrated cable was measured using the satellite simulator (Fig. 4). Then by subtracting the known delay of the calibrated cable, the RX-delay was found. Next, the sum of transmit (TX) and RX delay external to the modem IF TX-output and IF RX-input was measured using the satellite simulator (Fig. 3). The TX-delay was then found by subtraction of the calculated RX-delay. The difference between TX and RX delay was calculated. The transmit delay inside the modem was determined by using an oscilloscope to measure the delay between the transmitted 1PPS pulse and the resulting phase modulation change in the IF TX-output signal (Figs. 5 and 6). By subtraction of this delay from the sum of the internal transmit and receive delay in the modem, the receive delay was calculated. The overall difference between transmit and receive delays was then calculated. This difference was also determined at the travelling FAST Earth station, so the comparison of the results of co-location and the VSL satellite method was possible. Further details of the used procedures can be found in Annexes 1 and 2.

## EQUIPMENT

The equipment that was transported to the various sites fitted in a metal suitcase sized about 1 x 0.4 x 0.4 meter; its total weight was about 18 kg. It consisted of the satellite simulator, a source for the 1425 MHz translation frequency, and a 70 MHz CW unmodulated IF signal source and a set of coaxial cables. Both sources were phase-locked to the local 5 or 10 MHz clock frequency. A set of cables was also supplied. A wide band amplifier for 70 MHz was necessary to drive the satellite simulator 70 MHz port. The delay of this amplifier was also measured because it was part of the "calibrated cable" delay.

## VISITED LABS

The equipment was first used at NPL. The FAST team had a very tight schedule and had a very heavy task apart from setting up the FAST TWSTFT station. VSL introduced the equipment and assisted in the determination of the delays there; the internal modem delays at NPL were determined later. Then at VSL, the FAST station and modem delays were determined, as well as the VSL station and modem delays. The same was done by the station operators at PTB and TUG, but at FTZ and OCA there was not enough time. Later on also, the USNO and the NIST station and modem delays were measured by VSL. It was found that the applied power for the translation frequency, the 70 MHz IF frequency, and their power ratio had to be optimized to obtain the strongest mixer down-frequency signal from the Satellite Simulator.

## RESULTS

The results are given in Table 1. Two types of modems were in use. The first generation MITREX 2500 and the second generation MITREX 2500A (modified digital) modems made by Prof. Hartl at the University of Stuttgart, Germany. The 2500 internal TX and RX delays are grouped together, while the 2500A show a greater spread. The transmit and the filters inside the 2500A are small SAW filters, which have a larger group delay compared to lumped element filters for the same frequency and bandwidth. It appeared also that these two modems differed slightly in the 1PPS modulation method and associated timing. Details of the 2500 modem and the 2500A modem at PTB are shown in Fig. 7. It is not clear if, apart from the 200 ns offset, this difference gives other effects, such as different cross-correlation properties.

## CONCLUSION

Some systematic differences in modems have been discovered and consideration should be given to recommending only one modulation and timing method for MITREX modems and its compatibles because of the strong dependency of the TWSTFT accuracy on reciprocity.

From the comparison (Table 2) of the FAST co-location relative method and the satellite simulator absolute method to determine the non-reciprocal delays, we conclude an excellent agreement of the two methods to the 10 ns level.

The significant deviations of multiples of 100 ns between the two methods with the MITREX 2500A modems at USNO and PTB should be further investigated.

The overall conclusion is that if any station has measured its TX and RX delay difference using the satellite simulator calibration method, it can start accurate absolute time comparisons with any other station that has calibrated its delay similarly, provided the same satellite transponder is used.

## REFERENCES

- [1] G. de Jong, and M.C. Polderman, M.C. 1995, "Automated Delay Measurement System for an Earth Station for Two-Way Satellite Time and Frequency Transfer," Proceedings of the 26th Annual Precise Time and Time Interval (PTTI) Planning and Applications Meeting, 7-9 December 1994, Reston, Virginia, pp. 305-318.

- [2] J. DeYoung, A. McKinley, J.A. Davis, P. Hetzel, and A. Bauch 1996, "*Some Operational Aspects of the International Two-Way Satellite Time and Frequency Transfer (TWSTFT) Experiment Using INTELSAT Satellites at 90° E*," Proceedings of the 27th Annual Precise Time and Time Interval (PTTI) Applications and Planning Meeting, San Diego, California, 29 November-1 December 1995, in press.
- [3] G. de Jong, G. 1990, "*Accurate Delay Calibration for Two-Way Time Transfer Earth Stations*," Proceedings of the 21th Annual Precise Time and Time Interval (PTTI) Applications and Planning Meeting, 28-30 November 1989, Redondo Beach, California, pp. 107-115.
- [4] D. Kirchner, et al. 1995, "*An Automated Signal Delay Monitoring System for a Two-Way Satellite Time Transfer Terminal*," Proceedings of the European Frequency and Time Forum (EFTF), March 1995, Besançon, France, pp. 75-79.
- [5] J.A. DeYoung et al. 1995, "*The 1994 International Transatlantic Two-Way Satellite Time and Frequency Transfer Experiment: Preliminary Results*," Proceedings of the 26th Annual Precise Time and Time Interval (PTTI) Applications and Planning Meeting, 7-9 December 1994, Reston, Virginia, pp. 39-50.
- [6] G. de Jong 1994, "*Two-Way Satellite Time Transfer: Overview and Recent Developments*," Proceedings of the 25th Annual Precise Time and Time Interval (PTTI) Applications and Planning Meeting, 29 November-2 December 1993, Marina del Rey, California, pp. 101-117.
- [7] L.B. Veenstra 1991, "*International Two-Way Satellite Time Transfer Using INTELSAT Space Segment and Small Earth Stations*," Proceedings of the 22nd Annual Precise Time and Time Interval (PTTI) Applications and Planning Meeting, 4-6 December 1990, Vienna, Virginia, pp. 393-400.
- [8] D. Kirchner 1991, "*Two-Way Time Transfer Via Communication Satellites*," **Proc. IEEE**, 79, 983-990.

## ANNEX 1

Details of the Earth station delay calibration procedure using the NMI-VSL Satellite Simulator:

1. Make the set-up as described; refer to the Fig. 3. Be sure the down-converter is tuned to the Transmit frequency minus 1495 MHz for Europe and minus 2225 MHz for USA. To test the setup, connect a spectrum analyzer to the 70 MHz RX IF signal at point A. Set the Center Frequency of the spectrum analyzer to 70.000 MHz. The Transmit Gain at the Mitrex should be at +20 dB.

2. Switch the MITREX modem to Clean Carrier. You should now observe a clean carrier at the center. The signal strength should be at least equal to the normal RX clean carrier signal from the satellite. Adjust for maximum signal by rotating the SatSimulator, so the correct polarization is found. If the signal is too strong, place the SatSimulator closer to the rim of the reflector, or further away and insert extra attenuation at the 70 MHz input of the amplifier in the DF/5 harmonic generator box.

3. Switch the MITREX back from Clean Carrier, reconnect the RX IF cable to the MITREX, and try to lock on the signal by setting the RX code equal to the TX code. If locked, observe the P-signal meter; signal strength should be similar to the signal strength from the satellite. Fine-tune the receive frequency of the down-converter so that the delta-f meter shows near zero. If successful, proceed to the following step.

4. When locked to the signal of the SatSimulator, take readings from the Time Interval Counter (TIC). This value is the sum of all the TX and RX equipment delays: in the MITREX, the cables, the up- and down-convertors, the RF Power Amplifier, the feeds, the distance to the SatSimulator, the SatSimulator RF delay, and the Low Noise Amplifier. Note the averaged value as [1].

5. Now connect Calibration Cable end E to the 70 MHz TX output C and TX IF cable end C to 70 MHz output E of the 70 MHz CW generator, so they are interchanged (Fig. 4). The MITREX should again lock. Now the delay is measured of Calibration Cable + amplifier (E-F), SatSimulator IF port F to RF port, distance to the reflector, and the complete RX delays. Note the averaged TIC reading as [2].

6. Connect MITREX 70 MHz TX IF output C with a short known cable to 70 MHz RX IF input A. After lock, note the sum of the internal TX and RX delay of the MITREX modem corrected by the delay of the short cable as [3].

7. If not known previously, the delay [7] of the Calibration Cable E-F should be determined. For this we need two other cables that in turn can be connected to Calibration Cable end F. We can use the already present cables TX IF Cable C-D and RX IF Cable A-B.

7.1 Interconnect TX IF Cable end D and RX IF Cable end B. Cable ends C and D remain connected to MITREX output C and input A. We now measure the sum of the two cables (C-D) + (A-B). Note the value as [4].

7.2 Connect Calibration Cable end E to Mitrex TX IF output C, Calibration Cable end F to RX IF cable end B, and RX IF cable end A to Mitrex RX IF input A. Note this new delay as [5].

7.3 Leave Calibration Cable end E connected to TX IF output C, connect Calibration Cable end F to TX IF Cable end D, and TX IF Cable end C to RX IF input A. Note this delay as [6].

7.4 The delay of the Calibration Cable, including the amplifier (E-F), can now be calculated as:  $[7] = 1/2([5]-[3]) + ([6]-[3]) - ([4]-[3])$ . The delay of the used amplifier in Europe was:  $(3.1 \pm 0.3)$  ns. Twice the delay in the calibration cable branch inside the satellite simulator is added to this delay. This delay was  $(1.1 \pm 0.1)$  ns, so the value 2.2 ns was added to the final result.

8. The equipment RX RF delay from SatSimulator to MITREX RX IF input A is now calculated:  $[8] = [2] - [3] - [7]$ .

9. The equipment TX RF delay from MITREX TX IF output C to the SatSimulator is now calculated:  $[9] = [1] - [3] - [8]$ .

10. The RF TX-RX difference external to the modem  $[10] = [9] - [8]$ .

11. The TX delay inside the MITREX modem from 1PPS TX to 70 MHz TX IF output C is measured using i.e. a digitizing oscilloscope. Trigger on the 1PPS TX output and then determine the delay to the first 70 MHz phase reversal while using TX code 3 or 7. Note the value as  $[11]$ .

12. The RX delay inside the modem can be calculated:  $[12] = [3] - [11]$ .

13. The TX-RX difference inside the modem  $[13] = [11] - [12]$ .

14. The total TX-RX difference of the station is  $[14] = [10] + [13]$ .

15. This value  $[14]$  can be compared to results of this asymmetry correction by other relative methods, such as co-location. In that case, the TX-RX difference of this station also has to be measured by the Satellite Simulator method and half of the combined TX-RX difference is taken into account, as was done in Tables 1 and 2.

## ANNEX 2

### Details of the internal MITREX modem delay calibration:

In the MITREX modems 2500 and 2500A the 1 pulse per second (1PPS TX) is modulated on the pseudo-noise (PN) bit sequences (each sequence consists of 10000 chips of 400 ns, giving a total duration of 4 ms) by first delaying one sequence by a half-chip (= 200 ns) and then advancing the next sequence by a half-chip with respect to the normal timing.

MITREX codes no. 3 and no. 7 both appear to have the 2 last bits of their sequence equal to 1, and both have the first bit of its sequence equal 0, followed by a number of 1-bits. So the bit sequence near the beginning of a 4 ms period consists normally 800 ns of 1 (two last bits), 400 ns of 0 (first bit), and then the all 1's. When the 1PPS TX is modulated, the timing of the bits in MITREX 2500 is: 800 ns of 1, 600 ns of 0 (the first bit is extended from 400 ns to 600 ns), and then 1's. In the MITREX 2500A this is: 1000 ns of 1, 400 ns of 0, then all the 1's. So in the MITREX 2500, the beginning of the first bit coincides with the beginning of the 1PPS TX pulse used for the measurements, but in the MITREX 2500A this was true for USNO and FTZ, but not for PTB: the 1PPS TX is 200 ns extra ahead (see Fig. 7).

However, to accommodate the bandwidth restrictions required by the satellite operator, the MITREX modems have band filters in the transmit path. These filters exhibit a response time after applying a frequency signal for the first time and also after reversing the phase of the applied signal. It is this response time constant which gives a delay to the phase-modulated signal: after a filter the phase reversal is retarded with respect to the input signal. With an oscilloscope this displacement delay with respect to 1PPS TX can be measured.

Also amplitude changes (amplitude going to zero between phase reversals) are introduced: a resonant circuit can only reverse its phase at zero amplitude. We make use of this property to find on an oscilloscope the start of the first bit of the 4 ms sequence that contains the 1PPS TX information. This first bit in the MITREX 2500 has a pattern with a unique 600 ns width (and 1000 for 2500A), as already mentioned. The internal transmit delay is the time between the first edge of the 1PPS TX pulse and the zero-crossing and associated phase reversal at the beginning of the unique 600 or 1000 ns pattern at the 70 MHz TX output.

### Differences between MITREX 2500 and 2500A modems:

In the MITREX 2500 modem, the negative going slope of the 1PPS TX is "on time," while this in the MITREX 2500A is the positive slope. The output pattern of the MITREX 2500A differs slightly from that of the MITREX 2500 (Fig. 5). In the case of PTB, the 1PPS TX pulse is coming out too early by 200 ns, so the pattern was shifted by 200 ns. This correction has been applied in the reported data. In the Modem(TX+RX) delay values of the MITREX 2500A modems at FTZ and USNO, this 200 ns shift does not appear.

### Procedure:

1. Determine for the 1PPS TX signal the parameters used at the station for the Time Interval Counter input:
  - a. the slope of the first edge (negative for MITREX 2500 or positive for 2500A)
  - b. the trigger level for this edge (mostly +0.5 V)
  - c. the termination (50 ohm preferred)
2. Set the MITREX TX code to 3 (or 7).
3. Connect the 1PPS TX signal to channel 1 of the (digital) oscilloscope. Set the slope, trigger

level, and termination according to step 1. Set trigger source to channel 1 only. The first slope of the 1PPS TX pulse should now be visible.

4. Connect the 70 MHz TX signal to channel 2 (choose AC coupling, 50 ohm termination). Leave trigger source to channel 1. Set time base to 1 microsecond per div. If possible, use envelope averaging mode. Now find the unique 600 or 1000 ns wide pattern; the picture should be comparable to Fig. 5. When identified, change the time base and/or offset for the best resolution, so that the 1PPS TX slope is located near the beginning of the picture and the desired zero-crossing and the associated phase reversal is near the end (Fig. 6). Measure now the time difference between the trigger point on the 1PPS TX and the zero-crossing at the beginning of the unique 600 or 1000 ns pattern. The cursor readouts might be used for this. After correcting for the difference in cable delay of the used cables for channels 1 and 2 (and for the 200 ns 1PPS modulation shift in the case of a 2500A modem), this is the internal MITREX transmit delay between the 70 MHz TX output and the 1PPS TX output.



Table 1. TWSTFT station SATSIM calibration results in ns

STATIONS	FAST	VSL	TUG	NPL	NIST	PTB	USNO	FTZ
Date	94-10-03	94-10-01	94-10-17	94-09-27	94-12-14	94-10-08	94-12-09	92-12-03
Time	14:30		13:00		23:58	15:30	16:30	
MITREX Modem								
Type	2500	2500	2500	2500	2500	2500A	2500A	2500A
Internal Modem Delays								
TX+RX	1159.9	1194.7	1160.7	1158.7	1168.9	2054.8	1856.3	1867.0
TX	310.0	319.6	299.8	313.0	275.0	798.0	591.5	592.0
RX	849.9	875.1	860.9	845.7	893.9	1256.8	1264.8	1275.0
TX-RX	-539.9	-555.5	-561.1	-532.7	-618.9	-458.8	-673.3	-683.0
IF Delays								
TX+RX	2343.8			2371.2				
TX+CAL	2476.6			2433.5				
CAL+RX	2459.5			1772.3				
CAL+ampl.	740.2	698.8	558.7	139.6	332.9	1225.2	332.9	
RF+Mod. Delays								
CAL+RX	2475.1	2540.0		1435.8	1871.0	4542.0	2496.2	
TX+RX	2982.9	2532.6		1417.2	2581.5	4516.7	3162.8	
RF Delays								
CAL+RX	1315.2	1345.3	991.1	277.1	702.1	2487.2	639.8	
RX	575.0	646.5	432.4	137.5	369.2	1262.0	306.9	
TX+RX	1823.0	1337.9	854.5	258.5	1412.6	2461.9	1306.4	
TX	1248.0	691.4	422.1	121.0	1043.4	1199.9	999.5	
SATSIM								
CORR	2.1	2.1	2.1	2.1	2.1	2.1	2.1	
TX-RX	675.2	47.0	-8.3	-14.4	676.3	-60.0	694.7	
Total STATION								
TX-RX	135.3	-508.5	-569.4	-547.1	57.4	-518.8	21.4	

Table 2. Comparison of the SATSIM results to FAST co-location

STATIONS	VSL	TUG	NPL	NIST	PTB	USNO
Date	94-10-01	94-10-17	94-09-27	94-12-14	94-10-08	94-12-09
Time		13:00		23:58	15:30	16:30
Modem type MITREX	2500	2500	2500	2500	2500A	2500A
Total STATION TX-RX	-508.5	-569.4	-547.1	57.4	-518.8	21.4
Total FAST TX-RX	135.3	135.3	135.3	135.3	135.3	135.3
FAST-STATION (TX-RX)	643.8	704.7	682.4	77.8	654.1	113.9
0.5(FAST-STATION)	321.9	352.3	341.2	38.9	327.0	56.9
FAST CO-LOCATION	325.4	360.5	327.0		426.0	446.1
Correction N×100ns	0.0	0.0	0.0	0.0	100.0	400.0
DIFF FAST-SATSIM	3.5	8.2	-14.2		-1.0	-10.8

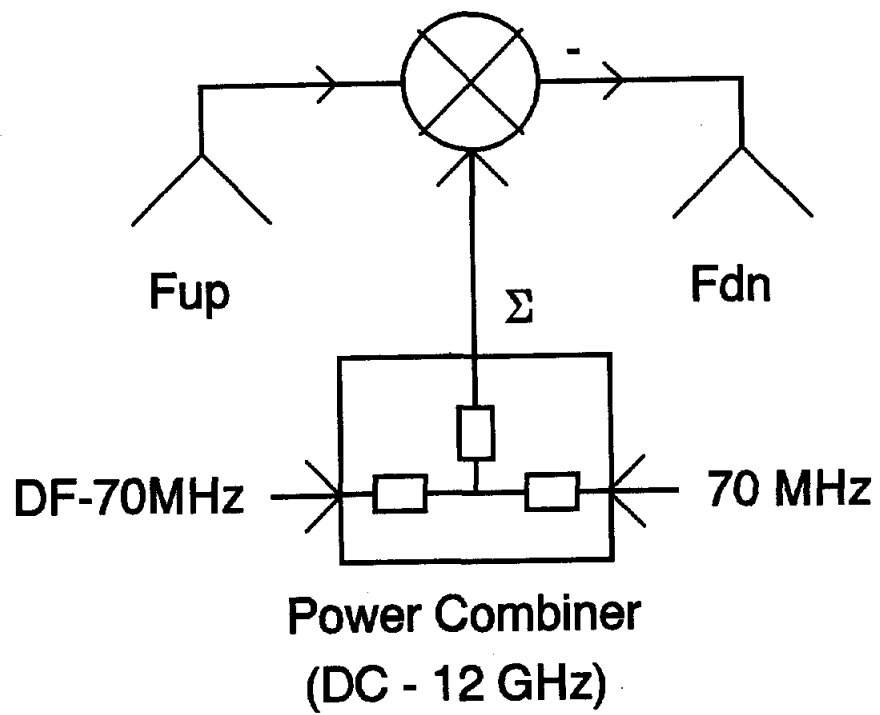

Fig. 1 Principle of the NMI-VSL Satellite Simulator

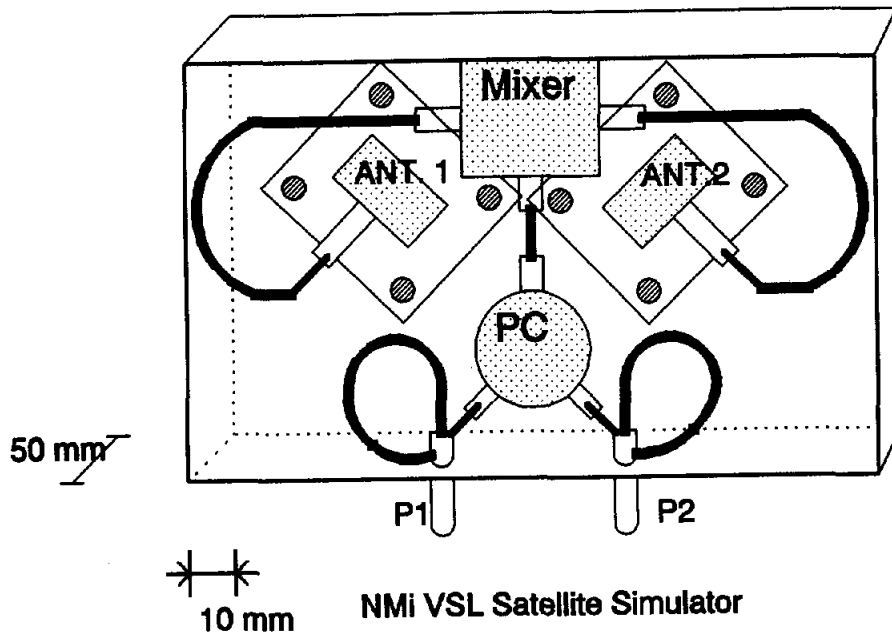

Fig. 2 Lay-out of the NMI-VSL Satellite Simulator

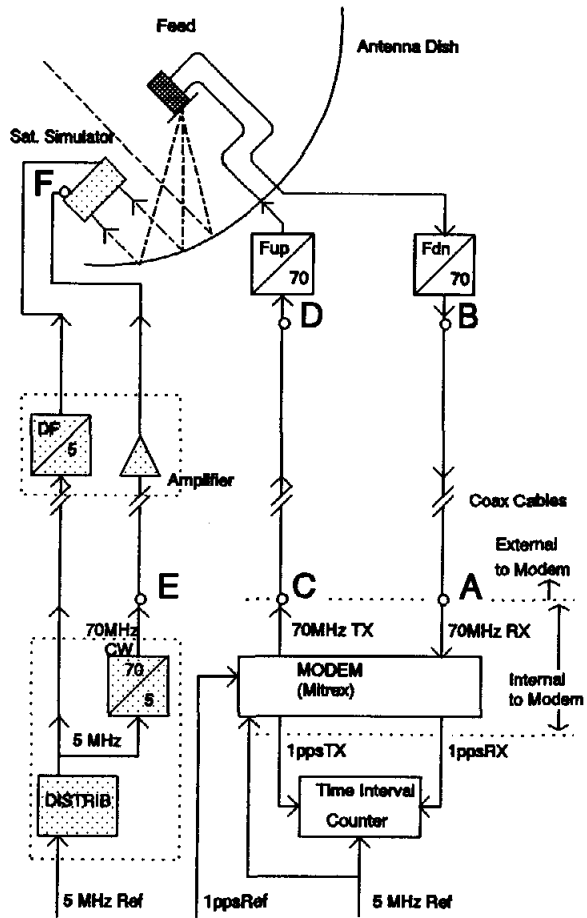

Fig. 3 Measurement of (TX+RX) delay with the NMI-VSL Satellite Simulator

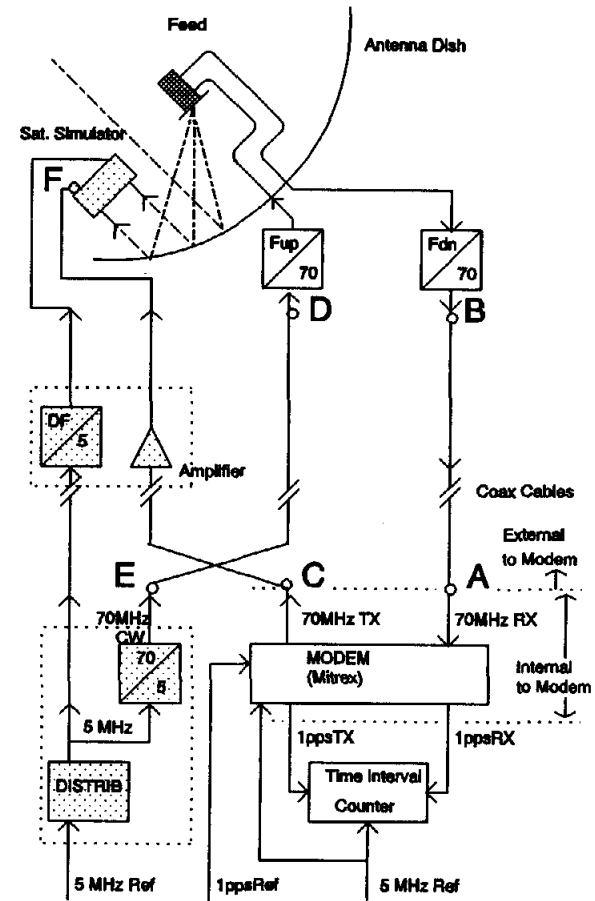

Fig. 4 Measurement of RF (CAL + RX) delay using SATSIM

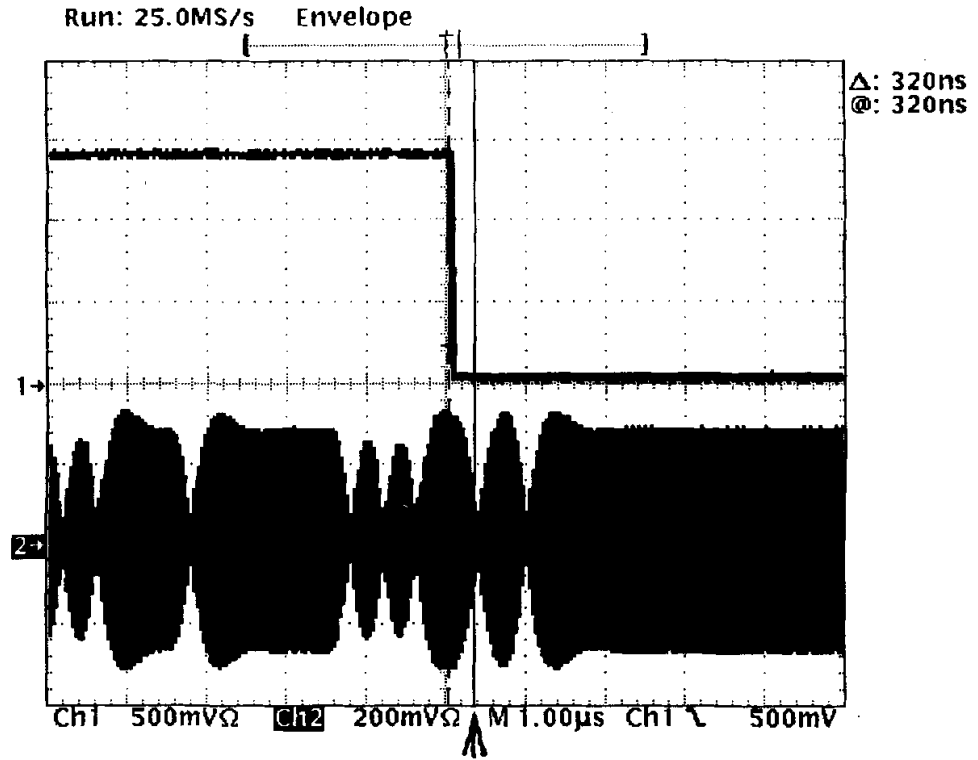

Fig. 5 The 70 MHz TX signal near the 1 PPS TX Ref. transition 1 us/div.

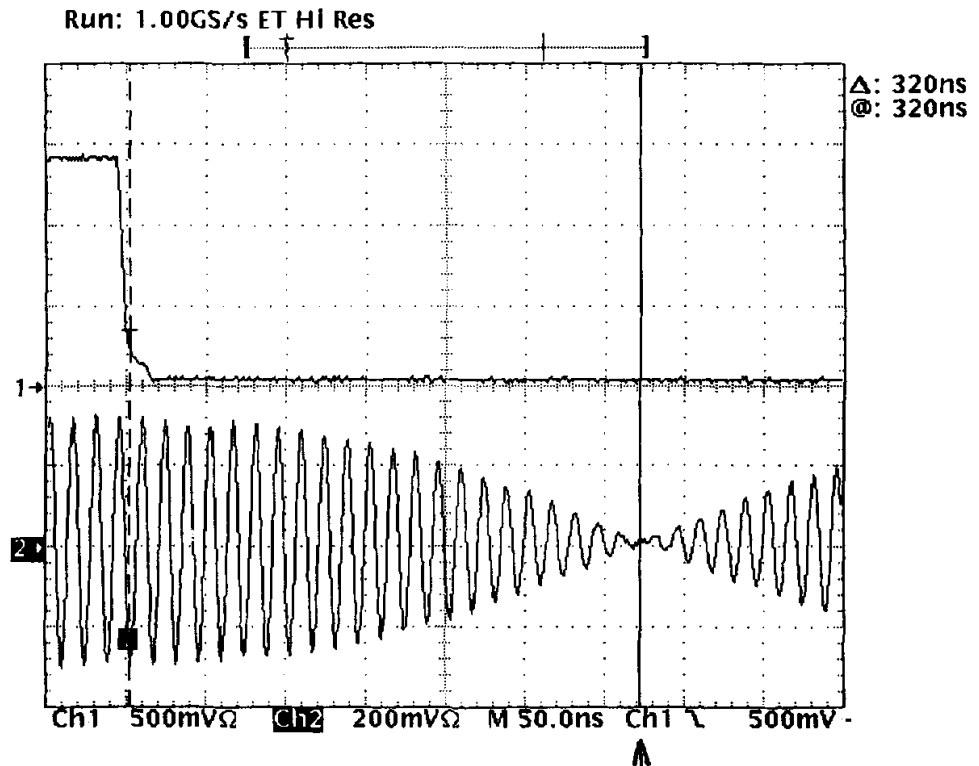

Fig. 6 The 70 MHz TX signal near the 1 PPS TX Ref. transition 50 ns/div.

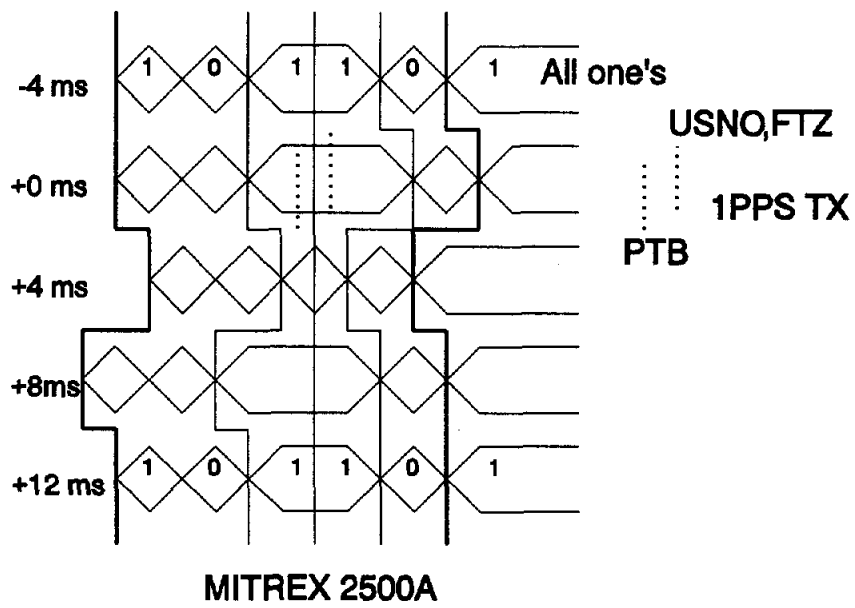
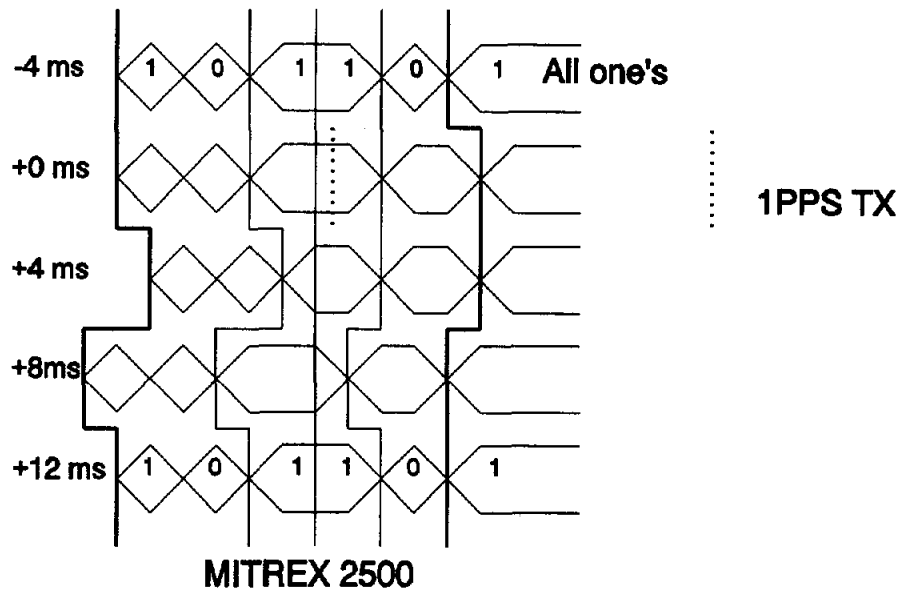

Fig. 7 Timing differences between MITREX 2500 and 2500A