

HIGH PRECISION TIME TRANSFER IN SPACE WITH A HYDROGEN MASER ON MIR

Edward M. Mattison and Robert F.C. Vessot
Harvard-Smithsonian Center for Astrophysics
Cambridge, Massachusetts 02138

Abstract

An atomic hydrogen maser clock system designed for long term operation in space will be installed on the Russian space station, Mir, in late 1997. The H-maser's frequency stability will be measured using pulsed laser time transfer techniques. Daily time comparisons made with a precision of better than 100 picoseconds will allow an assessment of the long-term stability of the space maser at a level on the order of 1 part in 10^{15} or better. Laser pulse arrival times at the spacecraft will be recorded with a resolution of 10 picoseconds relative to the space clock's time scale. Cube corner reflectors will reflect the pulses back to the earth laser station to determine the propagation delay and enable comparison with the earth-based time scale. Data for relativistic and gravitational frequency corrections will be obtained from a GPS receiver.

INTRODUCTION

Space qualified frequency standards having the frequency stability of the hydrogen (H) maser have a variety of potential applications in space, including very long baseline interferometry, improved navigation systems, tests of relativistic gravitation, and high precision world-wide time transfer. The Hydrogen Maser Clock (HMC) project is a NASA-sponsored experiment to design, build, and test in space an active-oscillation atomic hydrogen maser. The HMC maser instrument, which is being built by the Smithsonian Astrophysical Observatory, will be transported to the Russian Space Station Mir by the NASA Space Shuttle. It will be installed and operated on Mir in the last quarter of 1997.

The space maser's frequency will be measured by means of high-precision time transfer between the space-borne and earth-based clocks, using laser pulse timing. In this system time kept by a clock located at an earth-based laser ranging station (LRS) is compared with the space clock's time by measuring the arrival time of a laser pulse at the spacecraft in terms of both the space and earth time scales. A laser pulse transmitted from the LRS is detected at the spacecraft, and its arrival time is recorded with a resolution of 10 ps in terms of the space clock's time by a high-speed electronic event timer. The pulse is also reflected back to the earth by a retroreflector array mounted on the spacecraft, and is received at the LRS as a return pulse. The two-way propagation delay, measured in terms of the earth clock's time by an event timer located in the LRS, yields the pulse arrival time in terms of the earth clock. The measured

earth and space times provide a comparison of the respective clock time scales. Figures 1 and 2 are block diagrams of the major system components.

The Mir space station is in an orbit inclined at 51° and at an altitude of approximately 450 km. The earth-based LRS for measuring the frequency stability of the HMC hydrogen maser will be at the NASA Goddard Space Flight Center (GSFC), latitude 38° . GSFC is within range of Mir at least once, and sometimes several times, per day. With the expected system precision of better than 100 ps, we will be able to measure the space maser's frequency stability to a level of 1.2 parts in 10^{15} or better. The HMC time transfer system would be suitable for international high precision time transfer by other laser ranging stations within view of Mir.

INSTRUMENT OVERVIEW

The HMC instrument consists of:

- (i) the hydrogen maser physics unit;
- (ii) the electronics required to operate the maser and interface with the spacecraft;
- (iii) two laser event timer units that incorporate retroreflectors and photodetectors;
- (iv) a GPS receiver; and
- (v) a rechargeable silver-zinc backup battery system that will provide continuous operation of up to several hours during power outages.

The instrument is housed in a cylindrical support structure that will be mounted on the outside of Mir's Space Shuttle docking adaptor, shown in Figure 3. The complete HMC instrument package is 43.1 cm in diameter and 83.9 cm long, and has a mass of 200 kg. The instrument will consume on average approximately 156 to 188 watts of 28 volt d.c. power, depending on thermal conditions owing to the orientation of Mir as it orbits the earth.

The HMC instrument is operated by a microprocessor, called the Dedicated Experiment Processor, that monitors the maser's operation, gathers scientific data from the event timers and the GPS receiver, and controls the maser's operating parameters according to commands sent from the ground station and entered by Mir Cosmonauts. The GPS receiver will provide orbital position and velocity data that will be used to correct the space maser's time scale for relativistic and gravitational effects. In addition, the GPS receiver will send pulses to the event timers that will allow us to compare the HMC time scale with GPS time, and thus uniquely identify the laser pulses for comparison with the ground station.

THE HYDROGEN MASER PHYSICS PACKAGE

The H maser oscillator shown in cross-section in Figure 4 is the next generation of the maser built and flown in the 1976 Gravitational Redshift Experiment^[1, 2].

The TE-011 mode microwave resonant cavity made of Cer-Vit, within which is mounted a quartz hydrogen storage bulb, is contained in a titanium alloy vacuum tank. A double Belleville spring clamps the cavity endplates to the cylinder and is adjusted so that the compressive force is nominally independent of the length of the clamping structure, thus reducing the effect of thermal expansion on the cavity's resonance frequency. The cavity mounting base plate is attached in cantilever at its center to the base of the vacuum tank to isolate it from dimensional changes in the outer vacuum envelope. The maser signal is picked up by a coupling loop at a level of approximately -100 dBm and sent through an isolator and amplifier to a heterodyne receiver. A second loop within the cavity incorporates a reverse-biased varactor tuning diode to make small frequency adjustments to the cavity's resonance frequency.

Hydrogen is supplied from about 50 grams of lithium aluminum hydride contained in a heated stainless steel container whose temperature is controlled to maintain a constant hydrogen pressure within the container. Hydrogen flow to the maser's dissociator is controlled by sensing the pressure in the dissociator by means of a thermistor Pirani gauge, and regulating the temperature of a heated palladium-silver diaphragm through which hydrogen flows to the dissociator. Expended hydrogen is absorbed by two sorption cartridges that capture only hydrogen. Two small ion pumps with self-contained high voltage supplies remove other outgassing products. Frequency shifts from variation of the magnetic field within the maser storage bulb are controlled by 4 layers of passive shielding and by active field compensation. Magnetic field leakage through the outer shield is sensed by a flux-gate magnetometer and nulled by a compensating coil wound on the next innermost magnetic shield. This combination provides a shielding factor, $S = \Delta B_{ext} / \Delta B_{int} > 2 \times 10^6$, for external field variations of ± 0.5 Gauss. A two-layer flexible printed circuit solenoid closely fitted to the inside of the innermost shield produces a 0.5 milligauss uniform axial magnetic field within the cavity. With the available shielding factor, we can limit the fractional frequency effects of external field variations to less than 1 part in 10^{15} .

The temperature dependence of the resonance frequency of the cavity bulb combination is about -800 Hz/degree C. For frequency stability at 1×10^{-15} we require temperature stability on the order of 10^{-4} degrees C. This level of temperature stability is provided by a multi-zone microprocessor-controlled temperature stabilizing system.

LASER PULSE TIMING SYSTEM

The main components of the HMC time transfer system are the retroreflector array; an omnidirectional fiber-optic light collector; a photodetector and preamplifier; and the event timer, which consists of a constant-fraction discriminator and a time interpolation circuit (TIM) with a resolution of 10 ps. This system is shown in Figure 5. The space-qualified TIM, which has exhibited excellent repeatability and low systematic variation of measured time, is useful for a variety of precise space and earth timing applications.

The HMC retroreflector array consists of 20 fused silica cube corners, each 1 cm in diameter, mounted in a hemispherical base. This shape provides a hemispherical field of view, permitting reflections independent of spacecraft attitude. Laser pulses impinging on the retroreflector array are brought to a photodetector tube by an omnidirectional fiber optic light collector. The

collector consists of a 22-cm long bundle of 127 optical fibers, each 100 μm in diameter. At one end of the bundle the fibers are splayed out into a hemispherical pattern and inserted through holes drilled in a 1.5-cm diameter hemispherical shell that is mounted at the apex of the retroreflector array. The hemispherical fiber array ensures that at least one fiber is illuminated by light coming from anywhere in a hemispherical field of view. The other end of the fiber bundle connects to a photodetector tube (PMT) that detects the laser pulses.

The time transfer system's ability to resolve sub-nanosecond intervals results from a high-precision space-qualified event timer developed at the Los Alamos National Laboratory that is capable of timing with a resolution of 10 ps. The output pulse from the photodetector is sent to a constant-fraction discriminator (CFD), which produces a pulse whose shape is largely independent of the input pulse amplitude^[3, 4, 5]. This property of the CFD reduces the variation in triggering time that would otherwise result from the orders-of-magnitude variation in laser pulse intensity that can result from changes in atmospheric conditions and in spacecraft attitude and altitude.

The CFD's output pulse goes to the time interpolator^[6, 7], which is a combined digital and analog hybrid circuit that has the effect of subdividing the period of a 100 MHz clock signal by a factor of 1000. When a pulse triggers the time interpolator, a constant current I_c charges a capacitor until the next clock edge arrives. The capacitor is then discharged by a second constant current $I_d = I_c/1000$, and the discharge time is measured in terms of clock periods. By this technique the interpolator divides the 10 ns clock period into 1000 "bins", providing 10 ps resolution.

We have built and tested engineering models of the photomultiplier and event timer circuits. Measurements of the interpolator's integral linearity, which measures the total timing error for any bin compared to an ideal perfect interpolator, are shown in Figure 6. The maximum excursion of the integral linearity is less than 10 ps, with test-to-test repeatability of less than 1 ps, and variation of less than 5 ps in any bin from 10°C to 30°C. The resulting systematic variations in measured time are repeatable and can be calibrated to a few picoseconds.

DATA RETRIEVAL AND COMMAND

Data from the dedicated experiment processor will be stored in a specially modified IBM 750-C laptop computer located within the Mir cabin. Data will be transferred daily for transmission to the Russian Space Agency's ground stations.

The instrument's Dedicated Experiment Processor buffers telecommand signals exchanged between the HMC and the IBM 750-C. Pre-recorded command sequences, stored in the laptop will be executed by keystroke entry by a Russian Cosmonaut. These command sequences include the instrument power-up sequence, cavity resonator tuning, RF dissociator operating level, automated magnetic field measurement and functions for various diagnostic programs.

ACKNOWLEDGMENTS

The HMC contract is supported by NASA's George C. Marshall Space Flight Center, Huntsville, Alabama under contract number NAS 8 39194.

REFERENCES

- [1] R.F.C. Vessot, M.W. Levine, E.M. Mattison, E.L. Blomberg, T.E. Hoffman, G.U. Nystrom, B.F. Farrell, R. Decher P.B. Eby, C.R. Baugher, J.W. Watts, D.L. Teuber, and F.D. Wills 1980, "*Tests of relativistic gravitation with a space-borne hydrogen maser,*" *Phys. Rev. Lett.*, **45**, 2081-2084.
- [2] R.F.C. Vessot, M.W. Levine, E.M. Mattison, T.E. Hoffman, E.A. Imbier, M. Tetu, G. Nystrom, J.J. Kelt, H.F. Trucks, and J.L. Vaniman 1977, "*Spaceborne hydrogen maser design,*" *Proceedings of the 8th Annual Precise Time and Time Interval (PTTI) Applications and Planning Meeting, 30 November-2 December 1976, Washington, D.C., pp. 277-333.*
- [3] R.C. Smith 1988, "*Optimal design of high speed analog APD receivers,*" *SPIE Proceedings, 987 = Los Alamos National Laboratory Report LA-UR-88-3731.*
- [4] B.T. Turko, and R.C. Smith, "*A precision timing discriminator for high density detector systems,*" *Lawrence Berkeley Laboratory Report LBL-30602.*
- [5] B.T. Turko, W.F. Kolbe, and R.C. Smith 1990, "*Ultra-fast voltage comparators for transient waveform analysis,*" *IEEE Trans. Nucl. Sci.*, **NS-37**, 424.
- [6] R. Nutt 1968, "*Digital time interval meter,*" *Rev. Sci. Instr.*, **39**, 1342.
- [7] B. Turko 1984, "*Multichannel interval timer,*" *IEEE Trans. Nucl. Sci.*, **NS-31**, 167.

Hydrogen Maser Clock experiment overview

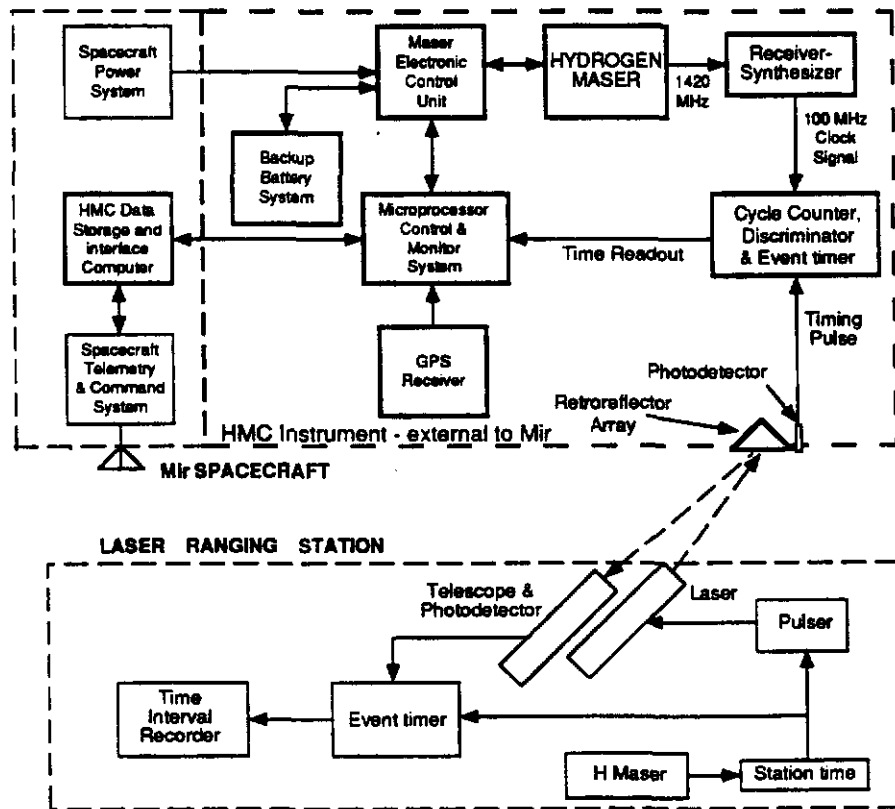
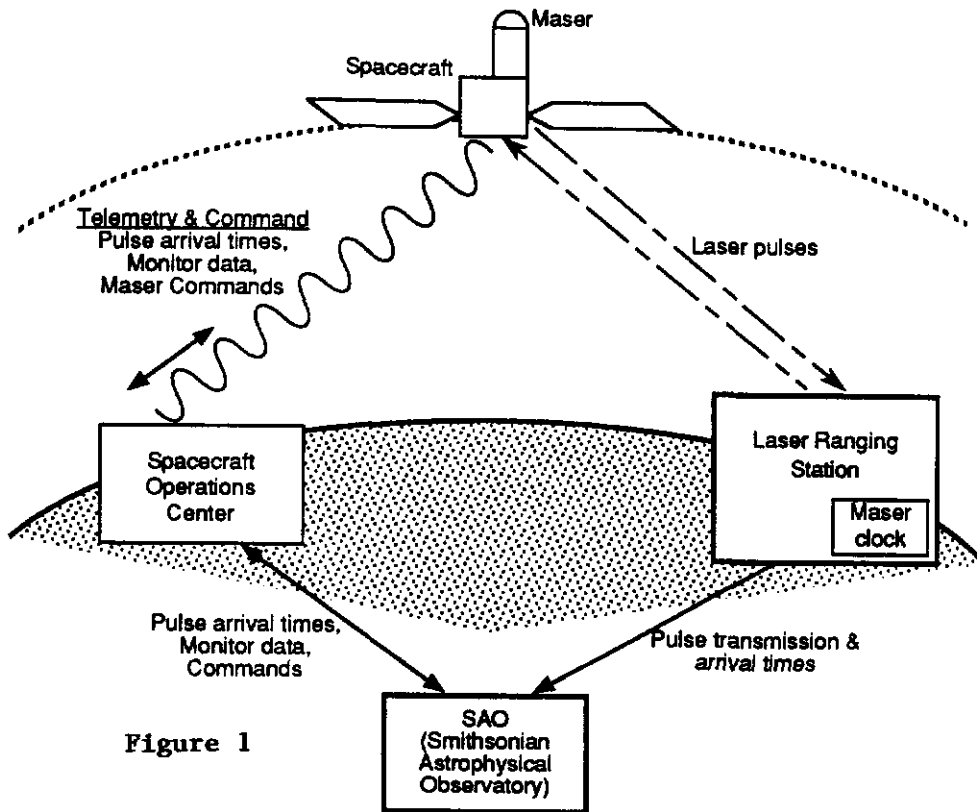

Figure 2

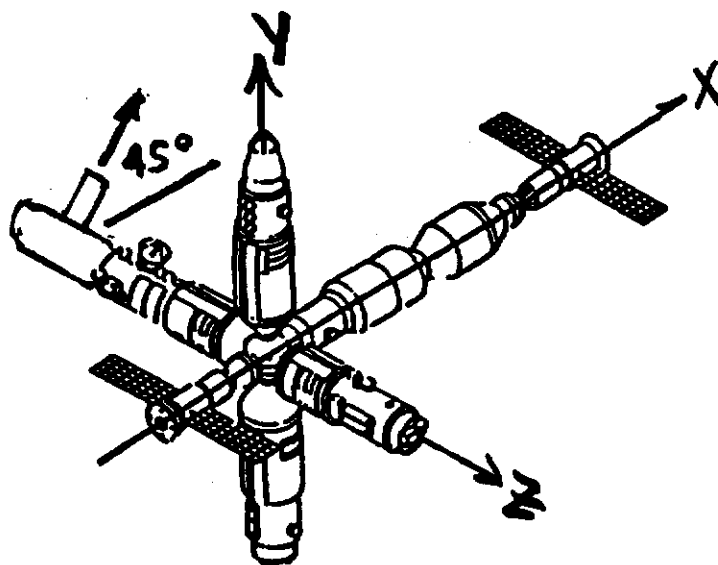
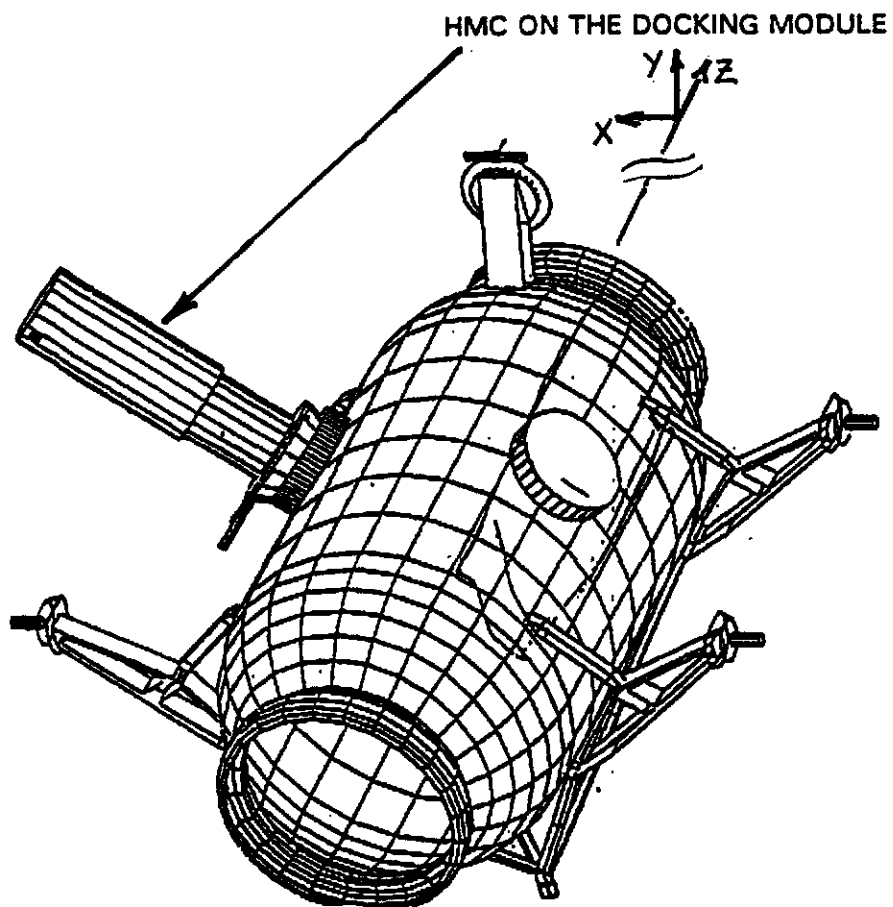

Figure 3 Location of HMC on Mir

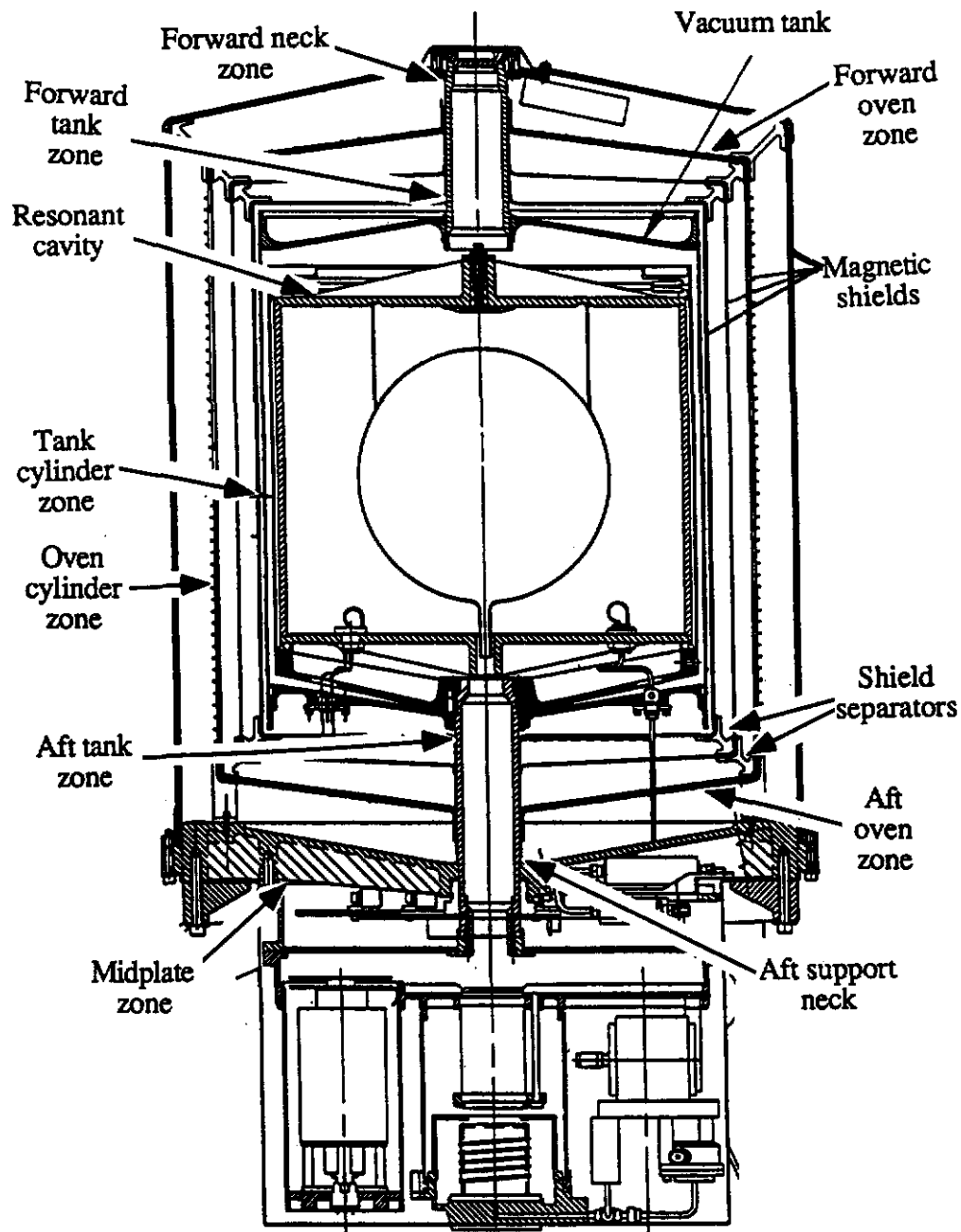
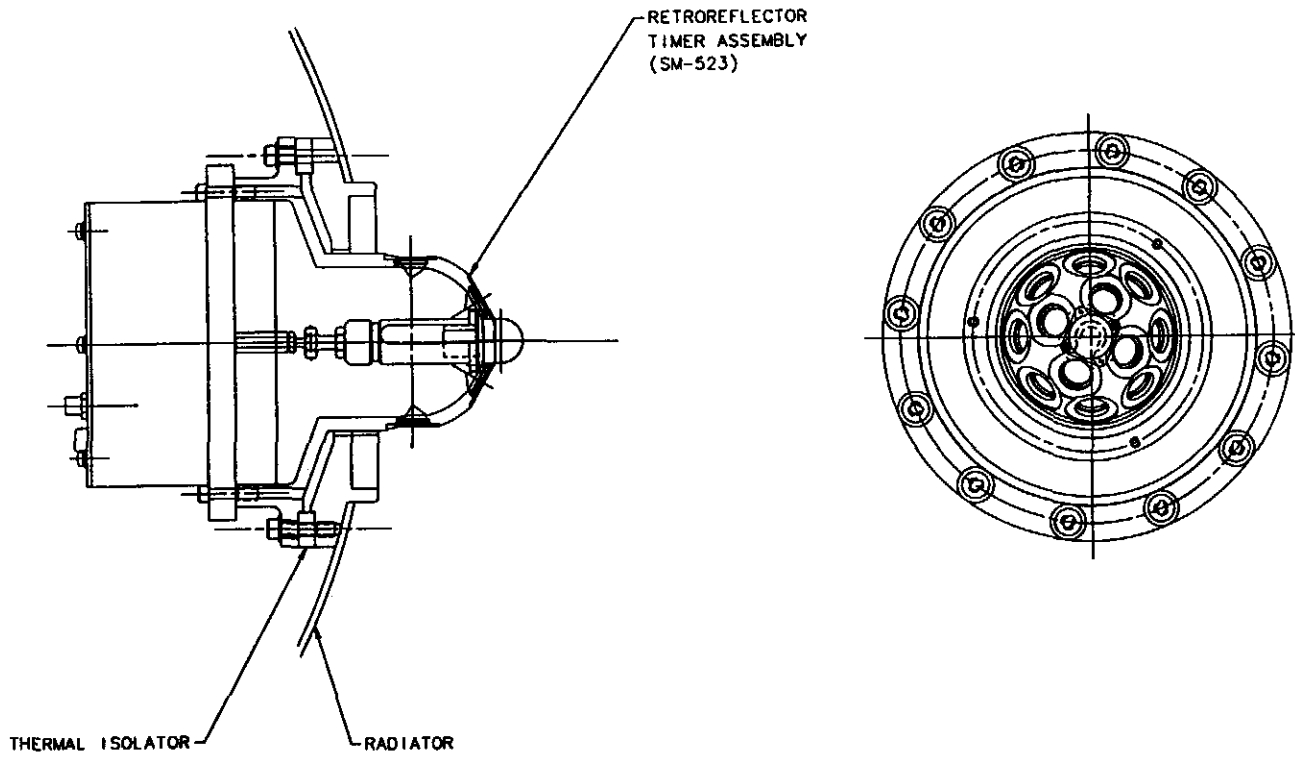

Figure 4 Cross section of Hydrogen Maser Oscillator



RETROREFLECTOR LAYOUT

Figure 5

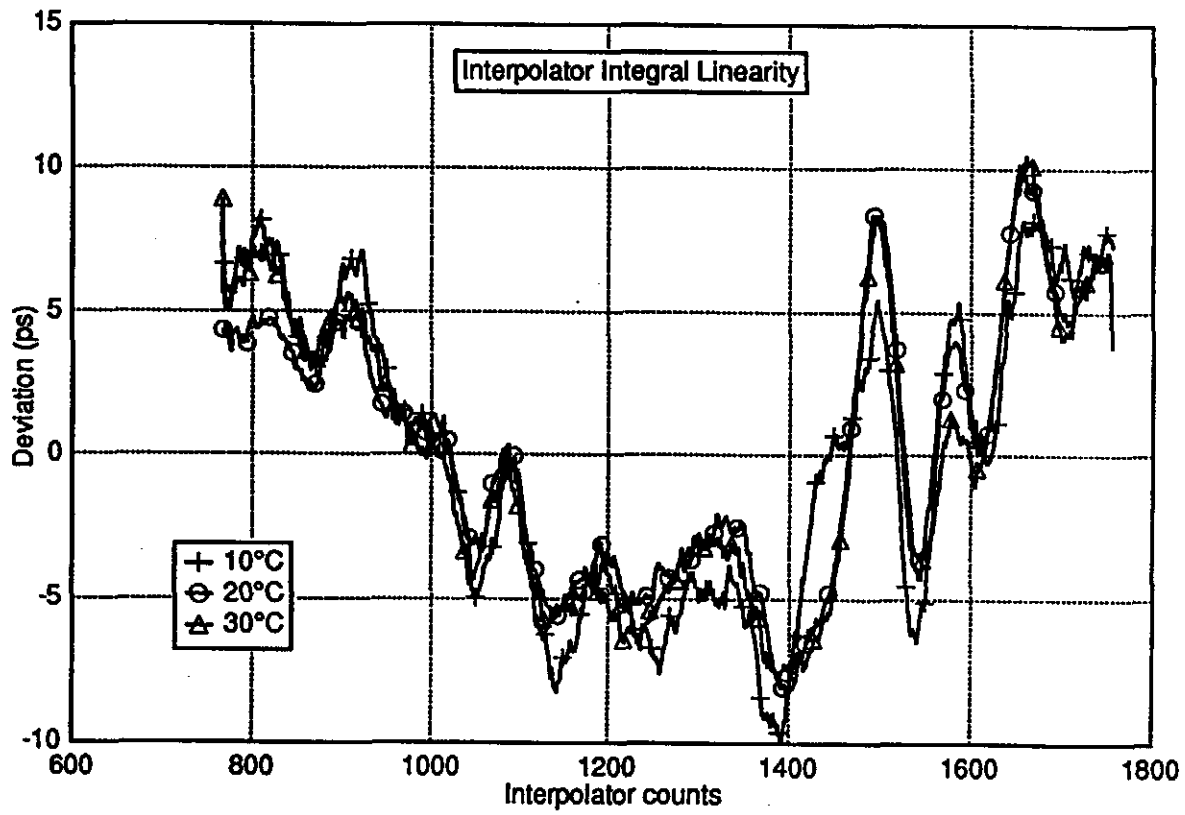

Figure 6

Questions and Answers

PIERRE J-M UHRICH (BNM-LPTF, PARIS OBSERVATORY): In the frame of the FARO Project, we have not yet chosen the space vehicle, and your maser will be launched on a space vehicle, which is not a geo-stationary one. In that case, you have a problem with following the satellites. You don't think you will have any problems following the satellite by using your laser pulse? That's my first question.

EDWARD M. MATTISON (SMITHSONIAN ASTROPHYSICAL OBSERVATORY): The worldwide laser ranging network does a lot of ranging to low-earth orbiting satellites. This is a little bit lower than they usually do, and there's a problem with tracking with a slew rate. But according to John Degnan at Goddard, there shouldn't be a problem. If I understand your question correctly.

PIERRE J-M UHRICH (BNM-LPTF, PARIS OBSERVATORY): Maybe we'll talk about this later.

EDWARD M. MATTISON (SMITHSONIAN ASTROPHYSICAL OBSERVATORY): As Christian said, you'll only see the satellite for maybe five minutes at a time. But, there is not an operational problem in following the spacecraft. Because it's low, you get a huge signal. There's not a problem with intensity.

PIERRE J-M UHRICH (BNM-LPTF, PARIS OBSERVATORY): The second point is that unfortunately laser links between the earth and satellites are sometimes subjected to perturbation and sometimes you have clouds over the countries. So there is a need – and this is also the case for the FARO Project – there is a need for a radio-wave link between the space vehicle and the ground. And as far as I know, you intend to do a radio-wave link. Could you comment on this?

EDWARD M. MATTISON (SMITHSONIAN ASTROPHYSICAL OBSERVATORY): We have in the past proposed an experiment "STFT," Satellite Time and Frequency Transfer, that uses a radio link with a pseudorandom code modulated signal to establish phase and to compare time. Frankly, we didn't have the money in this experiment to implement that. So, that would be an alternative method of transferring time.

You're absolutely right, we are limited by clouds, by weather; and that is the interest in having, for example, GPS as an absolute farout backup; but, of course, it doesn't give the kind of precision that we can get with the laser ranging. We could get, at best, 30 to 50 nanoseconds instead of on the order of 100 picoseconds resolution.

C. ANDY WU (THE AEROSPACE CORPORATION): What is the size and the power consumption required for this device?

EDWARD M. MATTISON (SMITHSONIAN ASTROPHYSICAL OBSERVATORY): The maser itself is about "that" big. The entire experiment includes the maser, its electronics; it's all housed in basically a cylindrical structure that is roughly a meter and a half long and about three-quarters of a meter in diameter; and the mass is currently 200 kilograms. That includes the outer structure, battery pack, which was necessitated by being on year, and a variety of other things.

