

LASER RETROREFLECTOR EXPERIMENT ON NAVSTAR 35 AND 36

E. C. Pavlis

Dept. of Astronomy, University of Maryland, NASA/GSFC 926
Space Geodesy Branch, Greenbelt, MD 20771

Ronald L. Beard

Space Applications Branch, Naval Center for Space Technology
U.S. Naval Research Laboratory, Washington, D.C. 23075

Abstract

In GPS one of the primary errors contributing to positioning inaccuracy is the performance of the on-board atomic clock. To determine and predict the performance of this atomic clock has been a problem due to the ambiguity of the orbital position error and clock uncertainty in the Radio Frequency (RF) tracking of the navigation signals. The Laser Retroreflector Experiment (LRE) on-board NAVSTAR 35 and 36 provides a means of separating these ambiguous errors by enabling highly precise and accurate satellite positions to be determined independently of the RF signals. The results of examining onboard clock behavior after removing the orbital position signatures will be discussed. GPS RF tracking data from various DoD and other sites are used to reconstruct the onboard clock data and examine the clock behavior. From these data, the effects of clock performance on GPS positioning performance can be examined.

INTRODUCTION

The purpose of this project is to identify and investigate means of enhancing the Global Positioning System (GPS) system integrity and performance. This project involves installing laser retroreflector arrays on-board Global Positioning System (GPS) satellites, tracking the satellites involved in cooperation with the NASA Satellite Laser Ranging (SLR) network and collecting these data for analysis and comparison with GPS pseudorange data. The Laser Retroreflector Experiment (LRE), previously known as the Advanced Clock Ranging Experiment (ACRE)⁽¹⁾, was submitted by the U. S. Naval Research Laboratory (NRL) to the TriDService Space Test Program for spacecraft integration funding as a triDservice space experiment. The objective of such an experiment is to provide an independent high precision measurement to compare or calibrate the GPS pseudorange signal. This project is a cooperative effort involving the NASA Goddard Spaceflight Center SLR group, the NRL and the University of Maryland. Installation of the LRE on the GPS satellite was performed in conjunction with the GPS Joint

Program Office and their contractor, Rockwell International, the Air Force Space Command and the Second Satellite Operations Squadron.

The GPS system is a predicted, real-time, passive ranging navigation system, made up of space, control and user segments. The space and control elements comprise the system proper, and the user segment operates passively utilizing the products of the system transmitted by the space segment. The user's information is computed from the control segment's tracking network's data and other data provided by external sources, such as the U.S. Naval Observatory (USNO) for Universal Coordinated Time (UTC) corrections. The tracking network data are similar in content to that used by the user segment and is relayed to the Master Control Station (MCS) for computation and prediction of the system states which are uploaded into the satellites for the users. Embedded in the space and control segments are atomic clocks to maintain all elements of the system in synchronization. These atomic clocks enable the precise time of propagation measurements (known as Pseudoranges) the users measure to determine range between themselves and the satellites, and the capability of determining the precise positions of the satellites needed as the users' position reference. Small, passive LRE on two GPS satellites, capable of supporting highly precise laser ranging to that satellite, tracked by a worldwide network of SLR stations are to produce highly precise and accurate orbital ephemerides. These data are being compared with GPS orbits generated by the MCS and the Defense Mapping Agency post-processed precise ephemerides to separate the satellite position and on-board atomic clock errors. This error separation should provide a foundation for better understanding the satellite clock on-orbit performance, error propagation within the MCS data computation process, and an independent calibration of GPS accuracy.

SATELLITE EQUIPMENT

The LRE is a panel of a laser retroreflector cubes, 24×19.4 cm (9.45×7.64 inches) as shown in Figure 1. This array consists of 32, 2.7 cm (1.06 inch) reflectors of the design used on-board Glonass satellites. These arrays were built and tested by the Russian Institute for Space Device Engineering in a cooperative arrangement with the University of Maryland. The placement on the selected satellites, NAVSTAR 35 and 36, is shown in Figures 2 and 3.

LASER TRACKING NETWORK

The laser returns from the LRE is estimated to be a factor of 36 lower than that of Glonass, whose array size is about 120×120 cm (47.2×47.2 inches), and a factor of 3 to 4 lower than Etalon (the Russian laser retroreflector satellite at Glonass/GPS altitudes). Good Glonass returns to the NASA mobile laser sites (MOBLAS) are roughly equal to that from LAGEOS. LAGEOS is routinely tracked by the NASA and cooperating laser sites. For Etalon tracking, a receiver threshold of 4 photoelectrons is used by MOBLAS for day/night operation. With the LRE and the same receiver threshold, the ranging returns are estimated to be 10 to 20 return, ranging returns could be increased to about the same level as Etalon if the receiver thresholds on the MOBLAS were reduced from four photoelectrons to one photoelectron (lunar mode) during night-time tracking. Daylight tracking from MOBLAS is more difficult due to the high

background noise rate and the single stop time interval units used rather than the multistop event timers used at the lunar ranging sites. Modifications to enable daytime tracking from MOBILAS has been prototyped and proven at the GSFC tracking site and the MOBILAS sites are being upgraded.

The results presented here are for NAVSTAR 35 only. NAVSTAR 36 was launched significantly later and has only been sporadically tracked. There are twelve sites which with varied frequency have successfully tracked NAVSTAR 35. The U.S. systems at Monument Pk., CA, Greenbelt, MD, Quincy, CA, McDonald Obs., TX, Haleakala, HI, Yarragadee, Australia and the international sites at Herstmonceux, U.K., Graz, Austria, Wettzell, Germany, Potsdam, Germany, Maidanak, Uzbekistan and Evpatoria, Ukraine. The distribution of the tracked "segments" by each of these stations indicate that some of the sites have only tracked over certain periods of time in a non-uniform way. This is due to the fact that tracking has been limited to daylight. Consequently, there are only short periods of a day or so when several sites were simultaneously successful in tracking the satellite. In particular, on November 18, 1993 ten passes of data were acquired. This is the reason why this day was chosen to do preliminary comparisons with the GPS-derived orbits for NAVSTAR 35.

GPS TRACKING

For intercomparison with the GPS derived data, these data are being collected at NRL along with the laser tracking data. Tracking data from the GPS Control Segment stations, USNO, the broadcast position data and DMA precise ephemerides are being collected. These data are continuous over the inOrbit operation of the satellites. To utilize the GPS derived tracking data for intercomparison with the laser derived data, the local clocks at the GPS Monitor Station sites must be accounted for since they are the basis for the GPS tracking measurements. In GPS itself these clocks are accounted for by the use of GPS Time which is a common synchronization time computed at the MCS. However, the GPS ranging measurements are directly related to the local clocks whose performance must be removed if the satellite clock is to be isolated from the satellite orbital position and evaluated. The laser data is independent of this influence on ranging measurements since the local clock is used for timetagging.

To determine the performance of the station clocks, common view time comparisons with USNO were made to the Colorado Springs, Hawaii and Ascension stations. These comparisons provide local station clock compared to the Master clock at USNO. These data show that large jumps and discontinuities are present as shown in Figures 4, 5, and 6. These jumps are due to changes in the local clocks or switching necessary for the operation of the system. Navigation users would not be aware of these changes since they use GPS Time which is a computed time accounting for these changes. For this experiment, removal of the local clock and the satellite position error by laser derived positions from the GPS tracking data will leave the satellite clock as the principal error component.

ORBITAL ANALYSIS AND RESULTS

The IERS Standards^[4] with minor excursions (e.g. JGM-2 gravity field vs. GEM-T3) have been adopted to ensure as much compatibility with other analyses results as possible. The orbits are integrated in the mean system of J2000 and only the terrestrial effects due to relativity are used. Modeling of the perturbing forces on the satellite is tailored after the LAGEOS SLR analysis standards. The exception is the limited gravity field terms (18,18) required here due to the higher orbit of the target satellite. The time-varying part of the geopotential is accommodated by modeling the solid Earth and oceans tidal accelerations and the secular change in the terrestrial oblateness. Because the NAVSTAR satellites are not passive as LAGEOS, attitude variations must be accounted for and the implications these have on the solar and thermal forces acting on the satellite a various times. The model used to describe these forces is the abridged version of Rockwell International's "ROCK42" model by Fliegel-Gallini-Swift, the T20^[5]. An additional acceleration along the satellite body-fixed Y-axis, the so-called Y-bias, is also adjusted. Due to the length of the arc used, once per revolution accelerations (with constraints) are also included and adjusted over the same intervals that the constant accelerations apply. The duration of these intervals is variable and they have been kept constant as long as the data allow in order to increase the robustness of the solution. The strategy followed has been to keep the same number of adjusted accelerations while lengthening the arc and to introduce a new set of accelerations once the data indicate a change in the orbit. These parameters along with the state vector at epoch are the only force model parameters that are adjusted.

Measurement modeling accounts for tropospheric refraction, tidal variations of the site including ocean loading (in all three directions), tectonic motions, and occasionally measurement biases. The tropospheric refraction model for SLR is the Marini-Murray model. Ocean loading effects at the SLR sites was computed using the Scherneck model for the eleven main tidal constituents of Schwiderskii's ocean tidal model. Tectonic motions for the sites are either from the LAGEOS-based solution SL8.3^[6] or the NUVEL-1NNR^[7]. Only simple measurement biases were adjusted on a few occasions for certain sites. Most of these biases are the result of "fine-tuning" of the ranging gates at the site in order to achieve the maximum number of returns possible. Once the sites are equipped with the better detection packages there should be no need to change these thresholds and therefore the chance of introducing biases to the data will be minimized.

The collected SLR data are analyzed and reduced based on the force and measurement models described in the previous section. A long arc of about 104 days was continuously extended as new data become available. This arc was used to check on the fidelity of the force model. The data fit the arc with an rms of 3 cm. The geographical distribution of the data set did not include southern hemisphere tracking and that can introduce significant biases in the orbits.

Table 1 shows the rms residual for each of the tracking sites. It is hard to assess the quality of the orbits without a uniform data distribution. November 18, 1993 being the best tracking day within our data set, it was used as a test day to verify orbit quality and gain some insight in the level of agreement with the "radiometric data"—determined orbits that the International GPS Service (IGS) for Geodynamics is routinely distributing^[8]. Two fourteen day arcs were

fit to the data; one for November 5–18 inclusive and one beginning on November 18. These arcs have only 12 hours worth of data in common: 11:00 UT to 23:00 UT, on November 18. The data fit either arc with an rms residual of about 1.9 cm. In both cases, the state vector and one set of accelerations were estimated. The two orbits are based on just over 200 normal points each. For arcs of such length this can hardly be called a sufficient amount of data. The trajectories from the two adjustments were then compared in terms of radial, cross-track, and along-track differences over their common segment. The statistics from this comparison (mean and rms about the mean), are shown in Table 2.

Table 1
Residual statistics for the 104-day SLR-determined arc

Site	No. of Obs.	RMS [cm]
Monument Peak, CA	311	2.3
Haleakala, HI	215	3.1
McDonald Obs., TX	81	2.7
Quincy, CA	4	0.1
Greenbelt, MD	8	1.0
Graz, Austria	175	2.8
Herstmonceux, U.K.	101	3.4
Potsdam, FRG	47	2.1
Wettzell, FRG	121	3.1
Totals	1063	2.9

Table 2
Trajectory Differences for the two SLR-determined 14-day arcs.

Component	Position [cm]			Velocity [cm/s]		
	Radial	Cross	Along	Radial	Cross	Along
Mean	5.1	21.8	-19.0	0.0028	0.0002	0.0012
RMS	3.2	37.0	10.9	0.0017	0.0015	0.0059

Despite the fact that the SLR data distribution is not as optimal as would be preferred for a precise orbit determination, it is still worthwhile comparing to the GPS-derived orbits distributed by IGS for geodetic work. The IGS orbit was rotated into the inertial frame and used as "observations" with the GEODYN data analysis software package to reconstitute a dynamic orbit fitting that data. The converged trajectory was then compared to the SLR-derived orbit in the radial, cross-track, and along-track directions (Figure 7). Statistics of these differences of the IGS orbit from both SLR 14-day arcs are shown in Tables 3 and 4. The common segment of course is only one day (November 18) in both cases.

Table 3
Trajectory Differences SLR-1 vs. IGS GPS orbit

Component	Position [cm]			Velocity [cm/s]		
	Radial	Cross	Along	Radial	Cross	Along
Mean	8.9	63.3	39.7	-0.0054	-0.0001	0.0004
RMS	7.7	56.5	75.1	0.0109	0.0102	0.0087

Component	Position [cm]			Velocity [cm/s]		
Direction	Radial	Cross	Along	Radial	Cross	Along
Mean	3.6	41.5	58.7	-0.0082	-0.0003	-0.0008
RMS	9.8	90.9	72.9	0.0103	0.0093	0.0138

CONCLUSIONS

The collection of the GPS tracking data is proceeding well and the SLR data is proceeding slowly. The complication of removing the local atomic clock offset and drift from the GPS data is being accomplished using the common view technique of simultaneous observations of the satellites at two sites. These comparisons should be of sufficient accuracy to remove these effects from the individual satellite tracking data. With SLR derived positions having sufficient confidence the resulting satellite atomic clock performance should be isolated for evaluation.

With limited SLR data, it is hard to come to firm conclusions. The two orbit comparisons show at least the level of compatibility of the SLR and IGS orbits at about 10 cm in the radial direction, whether it be in the mean or the rms sense. This is a very limited test, where neither technology has put forward its best accomplishments and capabilities. A much more uniform and extended SLR data set will be required before we can reliably determine an orbit at the few centimeter level of accuracy. On the other hand, reduction of GPS data directly within GEODYN will remove any inconsistencies in the standards and the reference frame used by the IGS analysis centers and the SLR group. Upcoming modifications to the SLR ground receivers will allow for a further increase in the tracking capabilities of several additional sites and add the needed southern hemisphere tracking. An initial effort to compare the SLR derived orbits with those distributed by IGS indicates that the two agree at the decimeter level radially and at the 0.5–1.0 meter level in the cross-track and along-track directions. The amount of collected data by site and geographical region is far from optimal for a reliable orbit determination, so these results should be interpreted with caution.

REFERENCES

- [1] R.L. Beard, "The Advanced Clock/Ranging Experiment (ACRE)," CSTG Bulletin No. 11, New Satellite Missions for Solid Earth Studies, Status and Preparations, DGFI, June 1989
- [2] R.S. Nerem, B.H. Putney, J.A. Marshall, F.J. Lerch, E.C. Pavlis, S.M. Klosko, S.B. Luthcke, G.B. Patel, R.G. Williamson, and N.P. Zelensky, "Expected Orbit Determination Performance for the TOPEX/Poseidon Mission," IEEE Trans. Geosci. Remote Sensing, 31 (2), 333–354 (1993).
- [3] C. Boucher, Z. Altamimi, and L. Duhem, "ITRF 92 and its associated velocity field," IERS Technical Note 15, Observatoire de Paris, IERS (1993).

- [4] D.D. McCarthy (ed.), IERS Standards (1992), IERS Technical Note 13, Observatoire de Paris, IERS (1992).
- [5] H.F. Fliegel, T.E. Gallini, and E. Swift, "Global Positioning System Radiation Force Models for Geodetic Applications," *J. Geophys. Res.*, 97 (B1), 559-568 (1992).
- [6] D.E. Smith, R. Kolenkiewicz, R.S. Nerem, P.J. Dunn, M.H. Torrence, J.W. Robbins, S.M. Klosko, R.G. Williamson, and E.C. Pavlis, "Contemporary global horizontal crustal motion," *Geophys. J. Int.*, 119, 511-520 (1994).
- [7] C. DeMets, R.G. Gordon, D.F. Argus, and S. Stein, "Current Plate Motions," *Geophys. J. Int.*, 101, 425-478 (1990).
- [8] G. Beutler, "The 1992 IGS Test Campaign, Epoch '92, and the IGS PILOT Service: An Overview," in: 1993 IGS Workshop, eds. G. Beutler and E. Brockmann, University of Berne, 1993, p. 3.



FIGURE 1

435

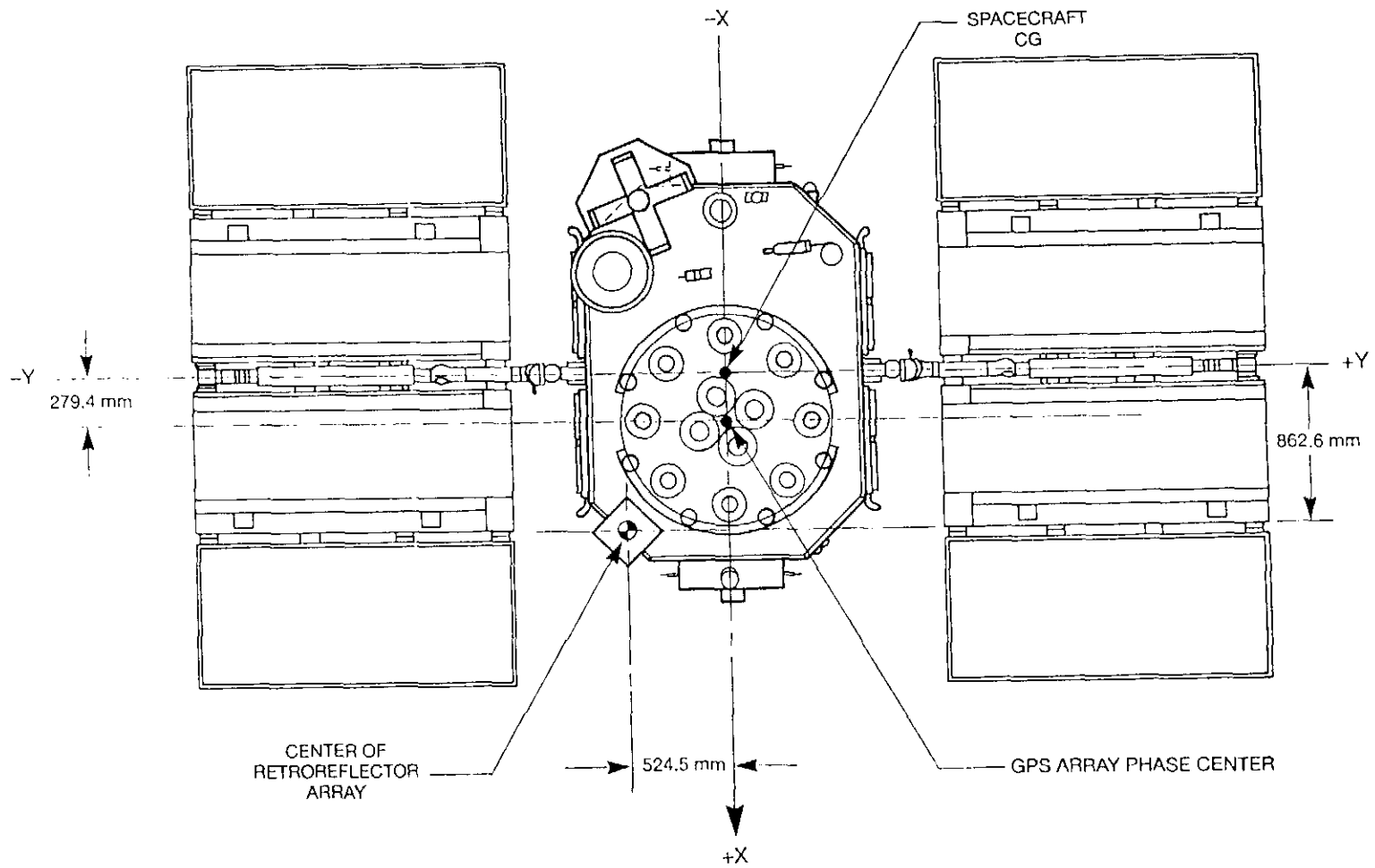

FIGURE 2

436

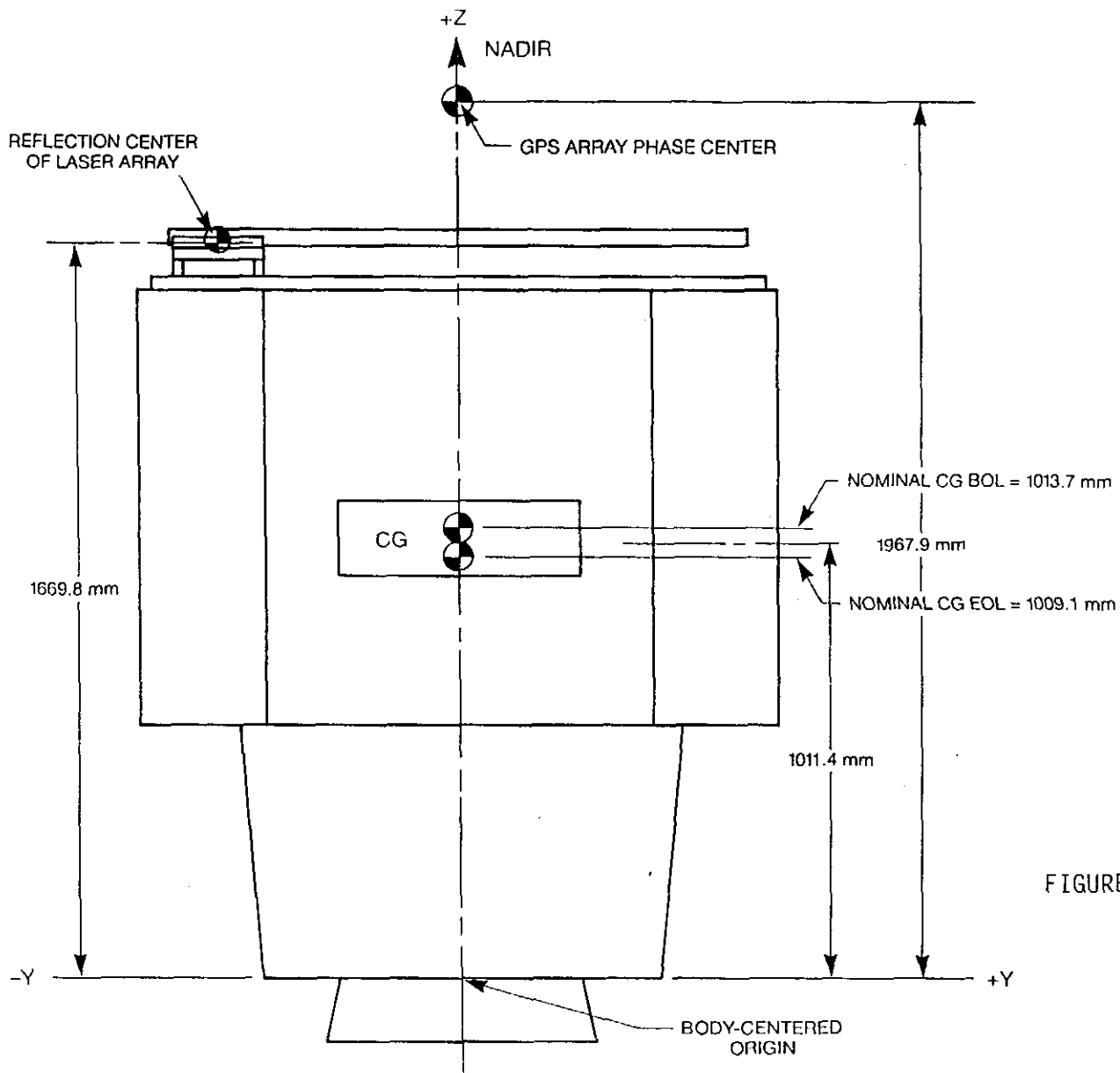
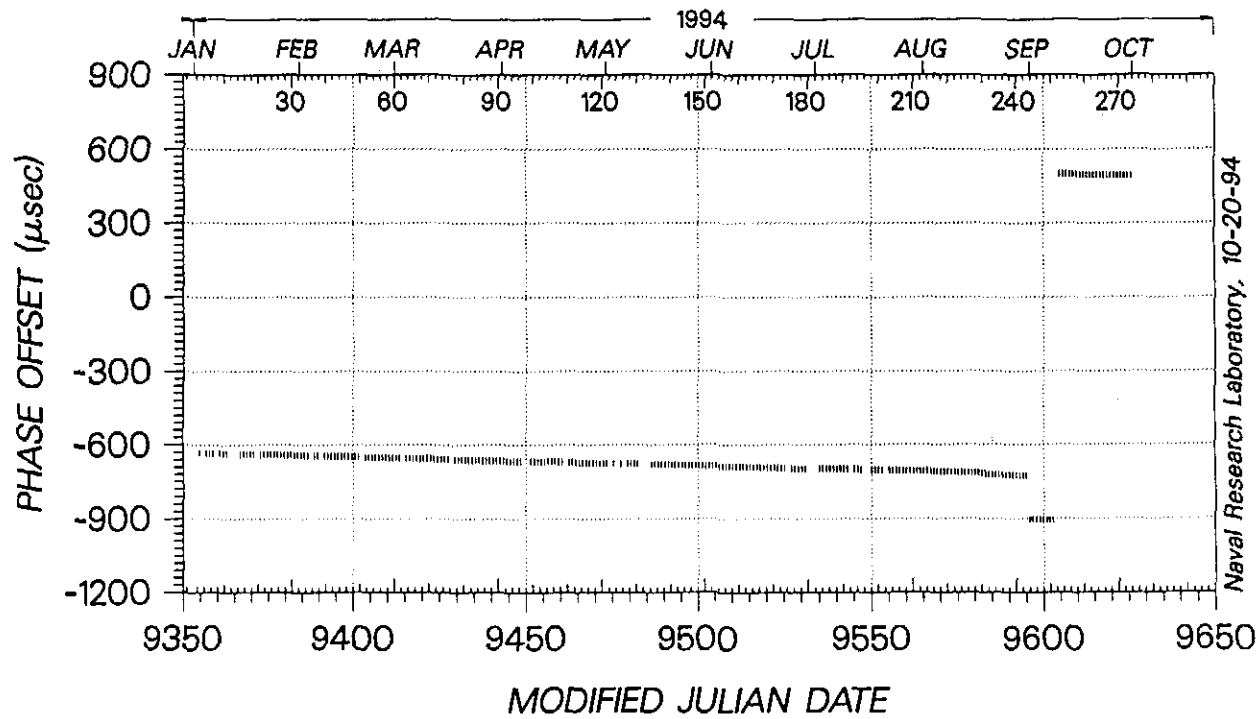

FIGURE 3

TIME TRANSFER VIA NAVSTAR 23
Colorado Springs Monitor Station
Naval Observatory, Washington, D.C.
PPS Receivers



Naval Research Laboratory, 10-20-94

437

FIGURE 4

TIME TRANSFER VIA NAVSTAR 23 CORRECTED LINEAR RESIDUALS
Colorado Springs Monitor Station
Naval Observatory, Washington, D.C.
PPS Receivers

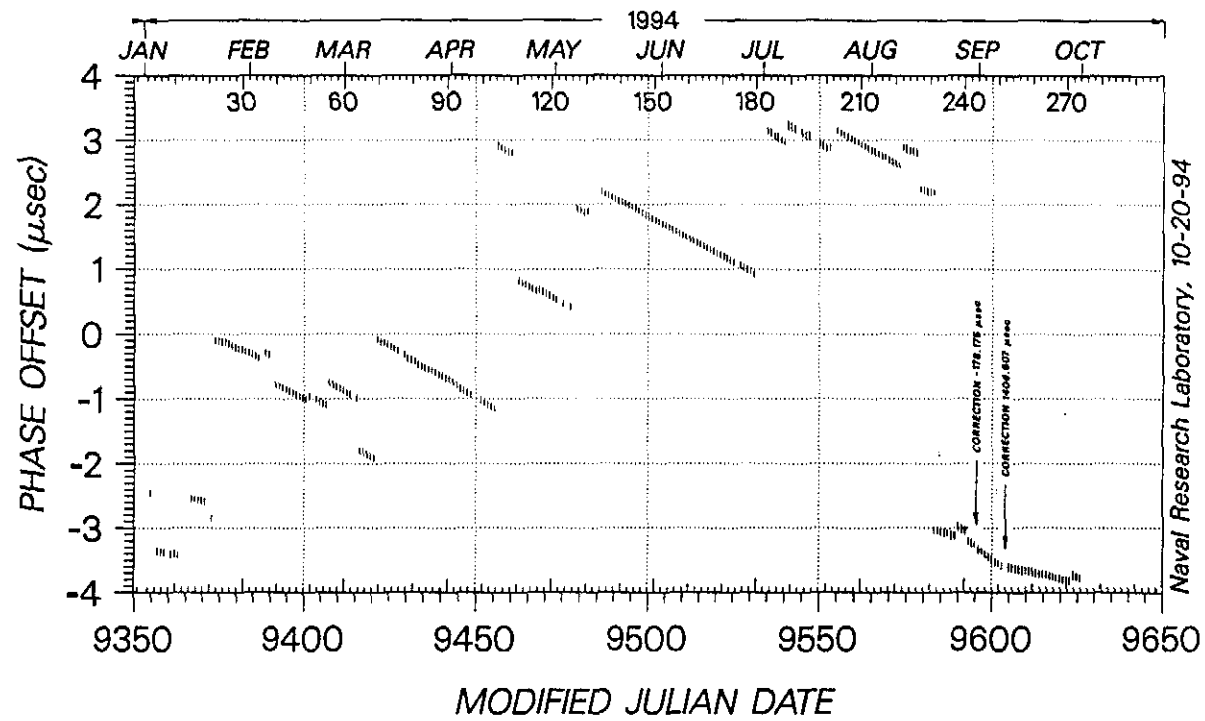

Naval Research Laboratory, 10-20-94

FIGURE 5

TIME TRANSFER VIA NAVSTAR 23 LINEAR RESIDUALS
Ascension Island Monitor Station
Naval Observatory, Washington, D.C.
PPS Receivers

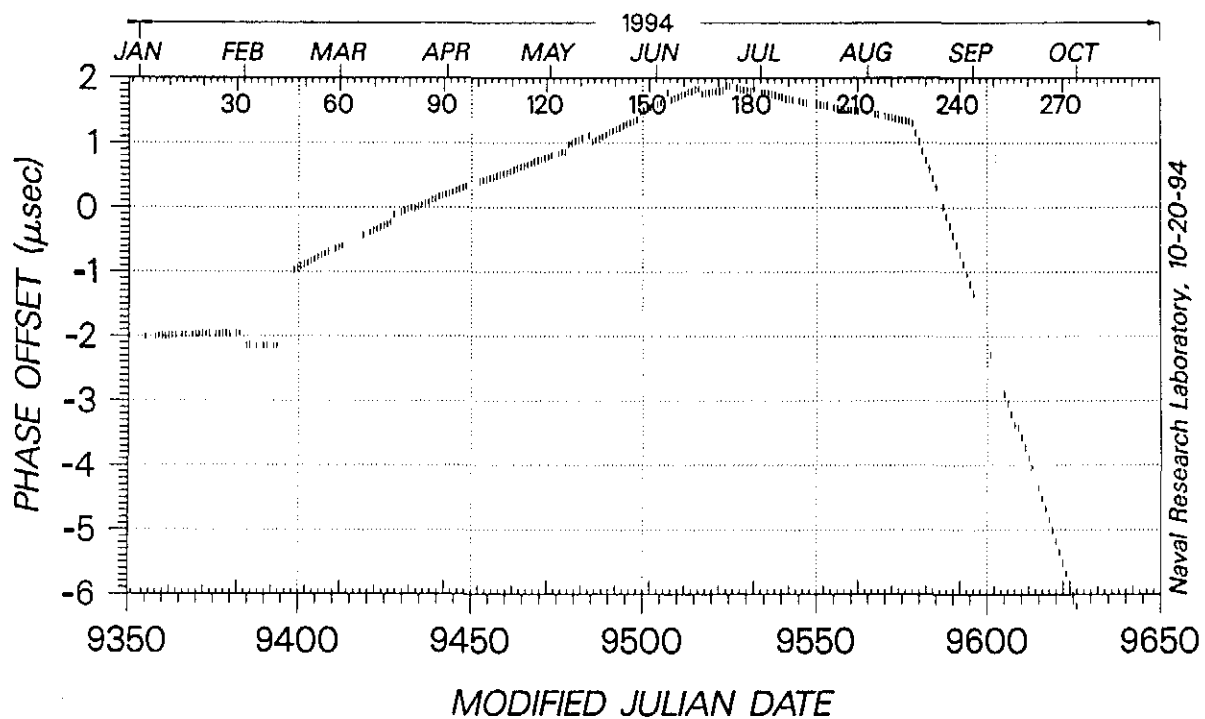

Naval Research Laboratory, 10-20-94

FIGURE 6

QUESTIONS AND ANSWERS

MARC WEISS (NIST): *On one of the plots of the residuals, I wasn't exactly sure what the data meant. There were normal plots for the laser ranging, and I thought they were open squares. Were those DMA or isiso-ephemeris ranging?*

RONALD BEARD (NRL): The normal points from the satellite data you mean?

MARC A. WEISS (NIST): Yeah.

RONALD BEARD (NRL): I think, as John mentioned yesterday, they are doing a number of pulses, like 10 pulses per second, to get the returns. They have taken like five minutes of these returns, and they averaged those into one, what they call a "normal point."

MARC A. WEISS (NIST): And you were comparing those on the same plot?

RONALD BEARD (NRL): The normal points are made to the raw range measurements, if that is the one I think you mean.

MARC A. WEISS (NIST): It's the first one. And then there was an RMS of some two millimeters. The open squares are what?

RONALD BEARD (NRL): *The open squares are the raw range measurements that they are making. They are getting like 10 a minute, or 10 a second.*

MARC A. WEISS (NIST): So the RMS is really the self-consistency of the range measurements with the laser.

RONALD BEARD (NRL): That's correct.

MARC A. WEISS (NIST): Okay. I understand that you're trying to do orbit reconstruction based on laser measurements only. And it seems that you can get a simple measure of the consistency by just looking at range measurements for your laser and range estimates from, say, DMA orbits or broadcast orbits. Has that been done?

RONALD BEARD (NRL): Yes and no.

MARC A. WEISS (NIST): That seems a lot simpler. I would be very interested to know how they compare simply for range measurements.

RONALD BEARD (NRL): It's a lot more difficult than it appears on the surface. That's one of the reasons we want to try to do some simultaneous tracking, so we can do just that. Even the locations of the stations and the lasers, it's difficult to get enough correlation between the two to just simply do a comparison of those two. But we have been trying.

JOHN LUCK (ORRORAL OBSERVATORY): First remark: I think the comparison between the SLR-derived orbits and the IGS orbits for 35 and 36 are consistent at about 15 to 20 cm level. The graph that you were just looking at is the self-consistent residuals for the laser-derived orbit.

My question was: Seeing that this is a very powerful tool for geodetic investigation, such as height determinations, sea-level monitoring and things like that, are there any plans to include

retro-reflector arrays on future GPS spacecraft? And if so, could you please make them bigger?

RONALD BEARD (NRL): Well, no and yes. There are no plans to include them downstream that I'm aware of. There are no specific plans. There are recommendations for doing that, and various options have been discussed. If we do, we sure have the world as our incubator.