

PRECISION FREQUENCY SYNTHESIZING SOURCES WITH EXCELLENT TIME / FREQUENCY PERFORMANCES

Liren Zhou, Hai Lin
Beijing Institute of Radio Metrology & Measurement
P. O. Box 3930
Beijing, China 100854

ABSTRACTS

Precision frequency synthesizing sources are needed in the time / frequency measuring system, atomic frequency standards, telemetry, communication and radar systems. This kind of frequency synthesizing sources possesses high frequency accuracy and excellent long term and short term frequency stability.

Several precision frequency synthesizing sources developed by Beijing Institute of Radio Metrology and Measurement (BIRMM) are described in this paper, which have been successfully applied to the time / frequency measuring system, atomic frequency standards system and radar system. In addition, the working principle, implementation approach and the main technical specifications obtained of the frequency synthesizing sources are also given in this paper.

INTRODUCTION

With the development of the electronic technique, the requirements for the frequency accuracy and stability of the signal sources grow higher and higher. In many electronic systems, it is required that the signal sources should work in the wider frequency band and possess excellent frequency stability and accuracy. All of these requirements bring out the development of the frequency synthesizing technique. With the advent of the large-scale integrated circuits (LSIC) and the applications of high-speed programmable divider, fractional divider and direct digital synthesizer (DDS), great progress has been made in some aspects of the modern frequency synthesizer such as output

frequency band, phase, noise, frequency stability and accuracy, frequency resolution, spurious suppression, etc.

Now, the modern frequency synthesizing technique has been widely applied to various electronic systems such as communication, navigation, measurement, frequency standards systems, etc. In this paper, several kinds of frequency synthesizing sources developed by BIRMM according to practical demands, as well as their characteristics, working principle and technical specifications are introduced.

MICROWAVE PHASE-LOCKED FREQUENCY SYNTHESIZING SOURCES

The microwave phase-locked frequency synthesizing sources developed by our institute have excellent frequency stability and accuracy as well as high frequency agile rate.

This frequency source adopts the digital phase-locked technique, the reference frequency source consists of the 100MHz crystal oscillator with high stability and isolated amplifier. The microwave frequency standards system consists of three low-noise microwave higher multipliers and selection switches. The single loop with the mixer is adopted in the phase-locked loop and the pulse-swallow programmable divider with low noise is added in the feedback circuit. In the loop, the low noise circuits are used in both the digital detector and loop filter. The control terminal of the voltage controlled oscillator (VCO) is equipped with the voltage presetting circuit so as to assure the quick and reliable locking of the loop.

The principle block diagram of the microwave phase-locked frequency synthesizer is shown in Fig.1.

In the design of the frequency synthesizer, the major consideration is to decrease the phase noises. In the phase-locked loop, the noises coming from every link will cause additional phase jitter at the output terminal, thus, degrading the quality of the output spectrum in the result. The mathematical model of the loop phase noises is shown in Fig.2.

In the figure, $S_{\varphi_{TN}}(\omega)$ —additional phase noise of the variable programmable divider; $S_{\varphi_{Tn}}(\omega)$ —additional phase noise of the fixed divider; $S_{\varphi_m}(\omega)$ —additional phase noises of

the frequency multiplier, mixer and switch circuits; $S_{\varphi_c}(\omega)$ —output phase noise of the crystal oscillating source; $S_{V_1}(\omega)$, $S_{V_2}(\omega)$ —noise voltages of the corresponding points of the loop; $S_{\varphi}(\omega)$ —additional phase noise of the voltage controlled oscillator (VCO); $e^{-\text{prtd}}$ —time-delay factor (leaving it out of consideration when analysing the noise).

The total output phase noise is:

$$\begin{aligned} S_{\varphi_0}(\omega) &= [S_{\varphi_c}(\omega)\left(\frac{N}{n} + M\right)^2 + S_{\varphi_{rn}}(\omega)\left(\frac{N}{n}\right)^2 \\ &= + \frac{S_{V_1}(\omega)}{K_{\varphi}^2} N^2 + S_{\varphi_m}(\omega) + S_{\varphi_{TN}}(\omega)] \cdot \\ &|H_r(j\omega)|^2 + [S_{V_2}(\omega)\frac{K_{VCO}^2}{\omega^2} + S_{\varphi_{VCO}}(\omega)] \cdot |H_{er}(j\omega)|^2 \end{aligned}$$

In the formula: $H_r(j\omega)$ —closed-loop transfer function of the loop; $H_{er}(j\omega)$ —error transfer function of the loop; K_{φ} —sensitivity of the phase detector; N —dividing ratio of programmable divider; M —times of the frequency multiplication; n —dividing ratio of fixed divider; K_{VCO} —voltage controlled sensitivity of the voltage controlled oscillator. In the formula (1), the phase noises at the loop output terminal are divided into two parts due to low-pass and high-pass filtering performances.

One part of the phase noises mainly comes from the reference source, fixed divider, phase detector, loop filter amplifier, frequency multiplier, variable programmable divider as well as their frequency dividing ratios N and n ; frequency multiplication ratio M , these phase noises are related to closed-loop transfer function of the loop and possessed of low-pass performance. Therefore, within the range of the loop bandwidth, the phase noises at the output terminal completely depend on the noise superposition of the above-mentioned elements in the loop and the phase noises beyond the range of the loop bandwidth will be attenuated.

The other part of the phase noises mainly comes from the voltage controlled oscillator VCO, which is related to the error transfer function of the loop and possessed of high-pass performance. Therefore, the phase noises of the output signal beyond the range of the loop bandwidth is mainly decided by the open loop feature of the voltage controlled oscillator.

In order to ensure the minimum output phase noise and spurious spectrum, the following measures shall be taken in the design of the phase-locked loop.

a. To use HF crystal oscillator with high quality and stability as the reference source so as to decrease affection of the noises and the times of the frequency multiplication as well.

b. In the feedback branch of the loop, the frequency dividing ratio N of the programmable divider increases the phase noises by N times of the reference source, fixed divider outside the loop (n), phase detector (PD) and low-pass filter (KF). So lower feedback frequency dividing ratio N shall be adopted as far as possible. In addition, variation of N results in the variations of the loop gain K and natural frequency ω_n , which certainly affects the stability of the loop. For this reason, the design using 3 direct selective microwave-frequency multipliers has been accepted.

c. To raise the phase discriminating frequency f_r , which can not only be useful for increasing the agile rate, but also be more effective for filtering the leakage of the phase discriminating frequency by means of the loop filter. Generally, $f_r / 2 \xi \omega_n > 10$.

d. To raise the phase discriminating sensitivity K_d and DC amplifier gain K_F so as to enhance the noise suppression capability of the loop.

e. To make the design of various parameters such as gain K , bandwidth ω and damping coefficient ξ optimum, therefore, optimizing the loop characteristics within the whole working frequency range.

The short term frequency stability of the frequency synthesizer at S waveband reaches $\sigma_T = 6 \times 10^{-11} / \text{ms}$; phase noise $L(f) < -100 \text{dBc} / \text{Hz}$, $f_m = 1 \text{kHz}$, $L(f) < -110 \text{dBc} / \text{Hz}$, $f_m = 10 \text{kHz}$. The frequency agile rate is lower than $40 \mu\text{s}$ when the phase stabilization reaches 0.1° .

Such kind of phase-locked frequency synthesizer is used for the measuring equipment and radar system.

The phase noise curve of the microwave phase-locked frequency synthesizer with output frequency of 3.5GHz is shown in Fig.3.

HF AND UHF SYNTHESIZING SOURCES

Now, the direct and phase-locked frequency synthesizing sources have been developed by our institute. The direct UHF synthesizer adopts the U_1 and U_2 frequency synthesizing units with BCD code step type, the step interval is 10kHz. Through twice up-conversions, the frequency is transferred to the UHF band. The stability at milli-second level is $7 \times 10^{-10} / \text{ms}$ in case the frequency is 320MHz and the phase noise $L(f) < -106 \text{dBc} / \text{Hz}$, $f_m = 1 \text{kHz}$, is $L(f) < -131 \text{dBc} / \text{Hz}$, $f_m = 10 \text{kHz}$. The frequency agile rate is less than $10 \mu\text{s}$.

The UHF phase-locked frequency synthesizing sources adopts the single-loop phase-locked system and take the 5MHz crystal oscillator with high stability as their reference source. In the loop, the specially designed digital phase detection and fractional divider with high sensitivity and low noise are adopted, the minimum step of the frequency dividing ratio N of the fractional divider is $1 / 10$. Thus, the non-phase correcting fractional frequency dividing circuit is used. The double mode predivider adopts $\div 4 / \div 5$ mode and directly works at UHF band. Moreover, the voltage controlled oscillator (VCO) in the phase-locked loop adopts the inductance sectionalization mode, thus ensuring a wide output frequency bandwidth and good phase noises. In the loop, the trapper is adopted to suppress the stray in the output signal. In case the output frequency is 410.5MHz, the phase noise $L(f) = -90 \text{dBc} / \text{Hz}$, $f_m = 10 \text{Hz}$, $L(f) = -102 \text{dBc} / \text{Hz}$, $f_m = -100 \text{dBc} / \text{Hz}$, $L(f) = -120 \text{dBc} / \text{Hz}$, $f_m = 1 \text{kHz}$, strays: -90dBc , $f_m > 3 \text{kHz}$. The frequency agile rate of the frequency synthesizer is less than 1ms.

In order to meet the demands for the development of the small-scale passive hydrogen (H) atomic frequency standards, we have also designed one kind of frequency synthesizers in its electronic system, which adopts the phase accumulating technique, its frequency resolution is better than 1mHz so as to satisfy the demands of the small-scale hydrogen clock electronic system on variable small frequency step.

CONCLUSION

This paper describes the achievements made by BIRMM in the field of frequency synthesizing technique in recent years. With the development of the frequency synthesizing technique and in order to meet the practical demands on the frequency stability measurement and atomic frequency standards, there is still much work to be done in the area of frequency sources, such as expanding frequency range, reducing phase noises; increasing frequency stability; developing high precision crystal oscillator with excellent long term and short term frequency stability, etc.

During the development work mentioned above, Mr. Ruida Mao and many colleagues gave us a lot of help, we wish to express our heartfelt thanks.

REFERENCES

- 1 Liren Zhou, "Technical report on development of total coherent agile microwave frequency synthesizer", BIRMM, 1990
- 2 Yujie Yang, "Technical report on IF synthesizer of the mobile telemetry station at S waveband", BIRMM, 1991.
- 3 P. Robins, "Phase noise in signal sources (Theory and applications)", 1982.
- 4 W. F. Egan "Frequency Synthesis by Phase Lock", Wiley-Interscience, New York 1981.

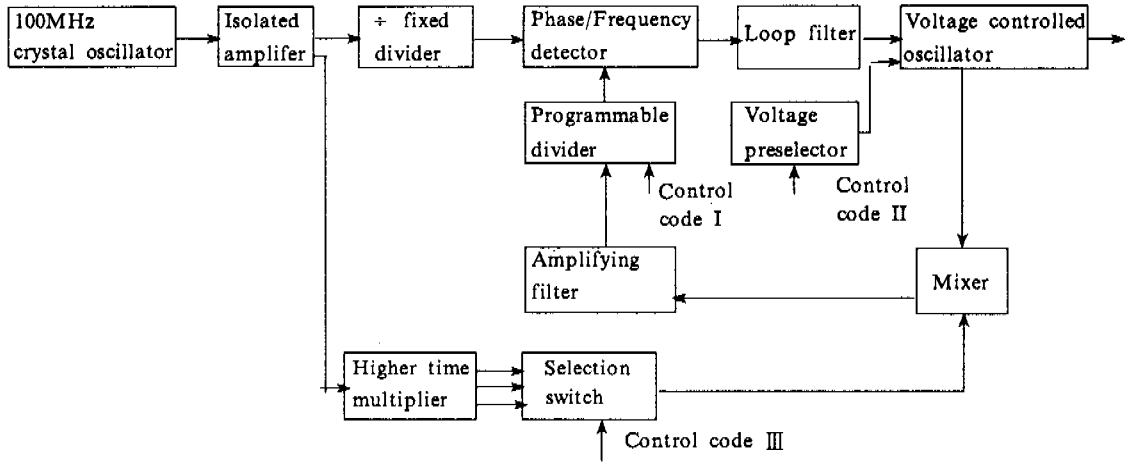

Fig.1 Principle block diagram of the microwave phase-locked frequency synthesizer

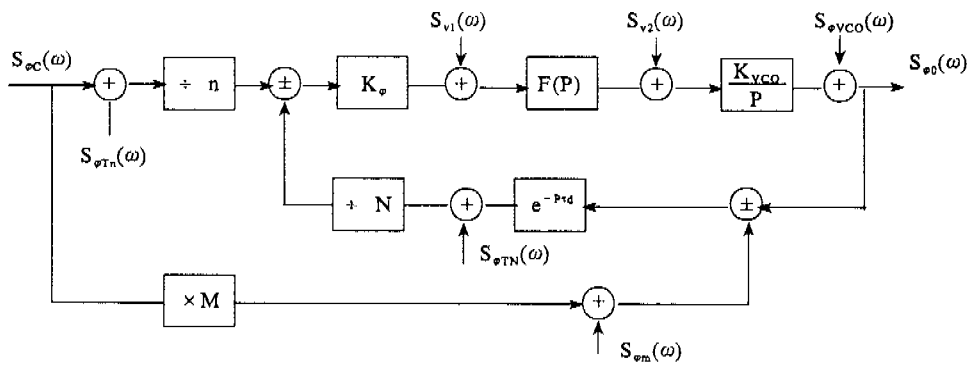

Fig.2 Mathematical model of the phase-locked loop noise

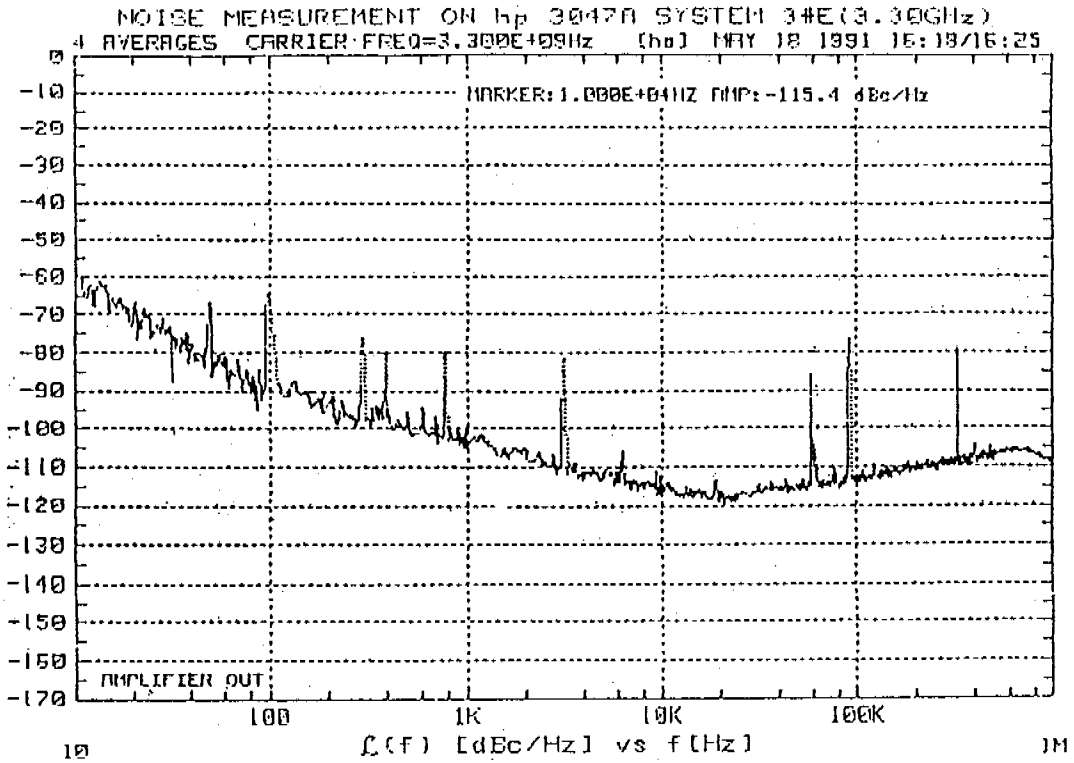

Fig.3 Output phase noise curve of the microwave phase-locked frequency synthesizer

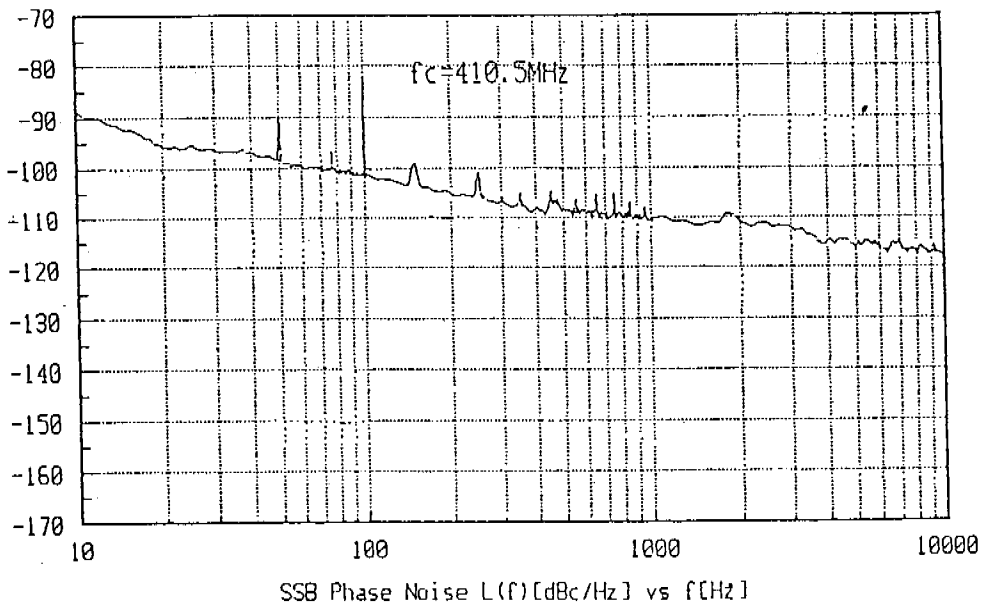

Fig.4 Output phase noise curve of the UHF phase-locked frequency synthesizer