

SOME APPLICATIONS OF GPS TIMING INFORMATION

Yinbai Zhang

Beijing Institute of Radio Metrology and Measurement

P.O. Box 3930

Beijing, China 100854

INTRODUCTION

GPS Satellites transmit two independent signals. One is C / A code (course acquisition signal) could be utilized by all civilian users. This service is called as Standard Positioning Service (SPS). Another is P code (precise signal) that could be only accessed by those authorized users. The service is called as precise positioning service (PPS). SPS C / A code users can navigate with accuracy of approximately 100m and timing accuracy of about 250–300 ns (1 sigma). Such timing accuracy is not enough for precision time and frequency value transfer. For this reason we must do some research work to improve the SPS C / A code accuracy which SPS users can get.

This paper presents our recently progress on timing information analysis, its data processing and its timing and frequency measurement applications.

GPS TIMING SIGNAL

As we know, GPS signal can give very precision timing information. Each GPS satellite has a Cs atomic clock on it. And GPS ground monitor and control stations continuously monitor and find out every GPS satellite's timing data error via comparison with UTC (USNO) standard timing signal. Then the ground correction data pouring station transmits the correction data to corresponding GPS satellite and the satellite transmits the data to users. The user equipment could process the timing data and output very precision timing signal.

Typical error budget of GPS time comparisons in common view is shown in Table 1.

THE EFFECT OF 'SA' TO TIMING ACCURACY

In order to reduce the C / A code application accuracy further, the measurement so called selective availability (SA) has been taken on Block II GPS Satellites.

According to GPS overall design the timing accuracy related to UTC (USNO) is about 100ns. Our experimental measurements indicated that the timing accuracy is reduced to about 300ns. (see Figure 1)

THE TECHNIQUES TO IMPROVE THE ACCURACY FOR TIME AND FREQUENCY SYNCHRONIZATION

1 Applying better ionospheric time delay error correction algorithm model

“Klobuchar” model is used for ionospheric time delay correction in Model 9390 GPS Time Frequency Monitor. It could correct the C / A L1 signal ionospheric error for only about 50% (refer to Figure 2). Therefore we should use a better algorithm model to improve ionospheric time-delay error which is one main error for GPS time and frequency transfer.

2 Using better data processing techniques, such as Kalman filter

We have developed a sort of clock-difference (TI value) data Kalman filter. The Kalman filter can filter out the additional noise introduced during the GPS signal is propagated from GPS satellite to user's equipments.

The design, and measurement results refer to Figure 3 and Figure 4.

3 GPS common-view time comparison could eliminate the effect of 'SA' to timing precision

This is due to SA is a conjugating error for users of commonview time comparison.

We have developed a GPS time interval data collector which is used to replace the on-duty microcomputer to collect clock difference data of GPS common-view time comparison.

We have used the accumulator for more than 3 months (from January 1993 to April 1993) to do the International GPS common-view time comparison with Asia and Pacific nations Time Standard Laboratories.

The block diagram of GPS time interval data collector is shown in Figure 5.

4 Deducing the frequency measuring uncertainty of GPS timing signal via enlarging overall measuring period

The limitation for frequency measuring accuracy depends on the following two factors: one is the long-term frequency stability of the GPS satellite on-board Cs atomic clock. Another one is the corresponding long-term frequency stability of GPS arrival signal at user equipment. GPS Satellite on-board Cs clock's frequency stability per day is about 1×10^{-13} . While the frequency stability per day of GPS signal at user equipment is about 3×10^{-13} without switching-on 'SA'. Under switching-on 'SA' it deduced to 10^{-12} level. We enlarged the sampling time interval to 10 days, the frequency stability per 10 days for GPS signal at user equipment is deduced to about 5×10^{-13} . Thus by means of enlarging the sampling time interval to 10 days we could measure frequency with accuracy less than $\pm 1 \times 10^{-12}$ (refer to Tables 2 and 3).

CONCLUSIONS

1. GPS Signal is a very useful, high-precision space information resource which can be shared anywhere in the world. GPS timing technique is the most accurate timing technique up to date.

2. According to the characteristics of time comparison we could process the time comparison data afterwards, use common-view technique, enlarge the measuring period and we only need tracking one GPS satellite for timing. We can fully use these characteristics to overcome "SA" effect to improve the timing accuracy.

REFERENCES

- [1] D. W. Allan and M. A. Waiss, Accurate Time and Frequency Transfer During Common-View of A GPS Satellite, Proc. of 34th Annual Freq. Control Symposium, May 1980.
- [2] B. Guinot et.al., Use of GPS Time Transfer at BIH / BIPM, Proc. of 19th Annual PTTI Applications and Planning Meeting, 1987
- [3] Zhongyang Li, Hongqin Liu and Yinbai Zhang, Time Transfer and Synchronizatin Using GPS Common-View Experiment, Proc. of International Symposium on Electromagnetic Metrology, August 1989, Beijing.
- [4] Zongyong Li, Hongjun Huang, Dongwei Jiang, Yinbai Zhang and Hongqin Liu, Comparison of Time Transfer and Frequency Made by BIRMM Using GPS, PROC. of APMP Seminar on GPS Common-View Reception, May 1993, HongKong.
- [5] Wlodzimierz Lewandowski and Claudine Thomas, GPS Transfer, Proc. of the IEEE, Vol. 79, No.7, July 1991.
- [6] Marc A. Weiss, The Design of Kalman smoothers for GPS data, IEEE Transaction on Instrumentation and Measurement, VOL.38, No.2 April 1989

Table 1 Typical error budget of GPS time comparisons in common view (CV), at distance d , C / A-code (Unit: 1 ns)

Error	For a single CV		For 10CV, average over 1 day ^①	
	$d =$ 1000km	5000km	1000km	5000km
• Satellite clock error (cancelled in CV mode)	0	0	0	0
• Antenna coordinates ^②	20	20	7	7
• Satellite coordinates	2	8	1	3
• Ionosphere (day time, normal solar activity, elevation $> 30^\circ$)	6	15	1	3
• Troposphere (elevation $> 30^\circ$)	2	2	0.7	0.7
• Instrumental delay (relative)	2	2	2	2
• Receiver software	2	2	2	2
• Multipath propagation	5	5	2	2
• Receiver noise (13-min average)	3	3	1	1
• Total	22	27	8	10

^①The noise of the laboratory clocks and the rise time of reference pulse bring nonnegligible contributions, which are not considered here.

^②Assuming uncertainties of the order of 3m. In practice, errors of coordinates can sometimes reach 30–40m.

Table 2 The measurement results of GPS signal at user equipment

GPS signal frequency stability per day	GPS SV Number	Date Y M D	The length of measurements	The RMS of measurement residuals	The A_0 value of fit curve with 2nd items	Note
1.31×10^{-12} 2.60×10^{-12}	28	93 06 27	820	94.5	75753.8	BLOCK II ('SA')
		93 06 28	840	111.9	75867.2	
		93 06 29	820	64.6	75642.4	
2.07×10^{-12} 2.36×10^{-12}	27	93 06 27	810	63.8	75896.6	BLOCK II ('SA')
		93 06 28	840	44.2	75718.1	
		93 06 29	840	77.2	75921.9	
1.24×10^{-12}	12	93 06 27	840	3.2	75882.3	BLOCK I
		93 06 28	840	0.9	75774.8	
1.49×10^{-2}	03	93 06 26	840	4.1	76032.0	BLOCK I
		93 06 27	840	10.2	75917.4	
		93 06 28	840	2.3	75775.1	

Table 3 The comparison between GPS signal frequency stability for 1d and 10d

SV τ	03	13	26	27
1d	2.96×10^{-13}	3.78×10^{-13}	1.29×10^{-12}	1.28×10^{-12}
10d	1.51×10^{-13}	2.71×10^{-13}	3.78×10^{-13}	2.48×10^{-13}

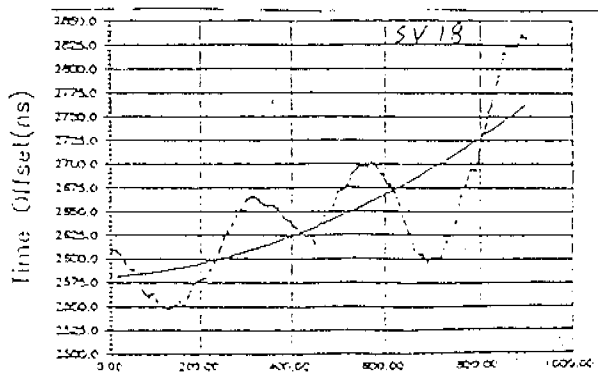
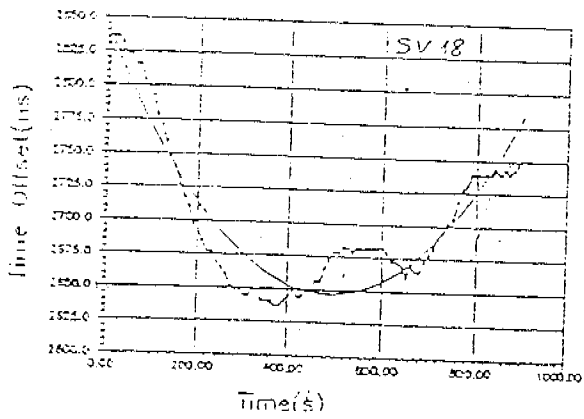
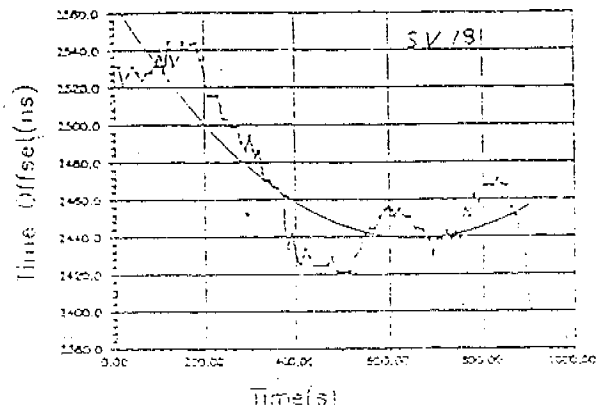
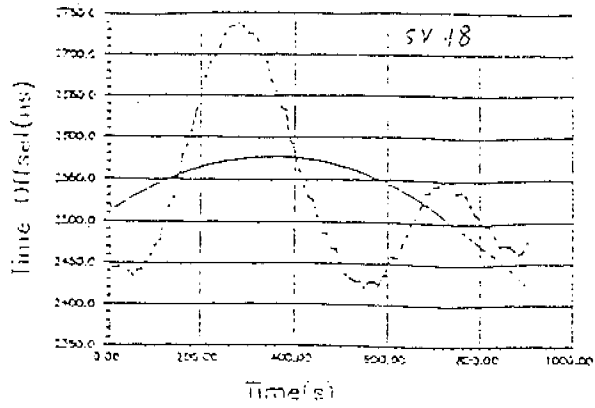

Fig.1. GPS sv 18
(Block II) T1Curve

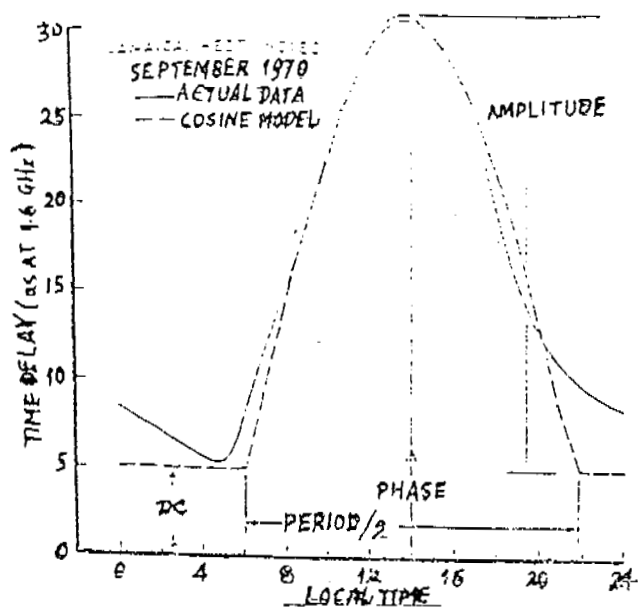

Fig.2. Klobuchar Algorithm Model

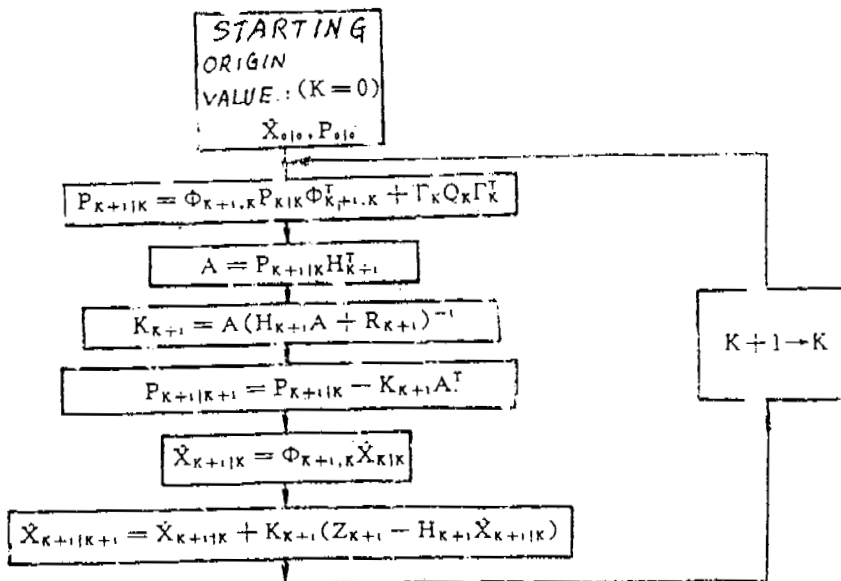

Fig.3. Standard Kalman Filter Algorithm

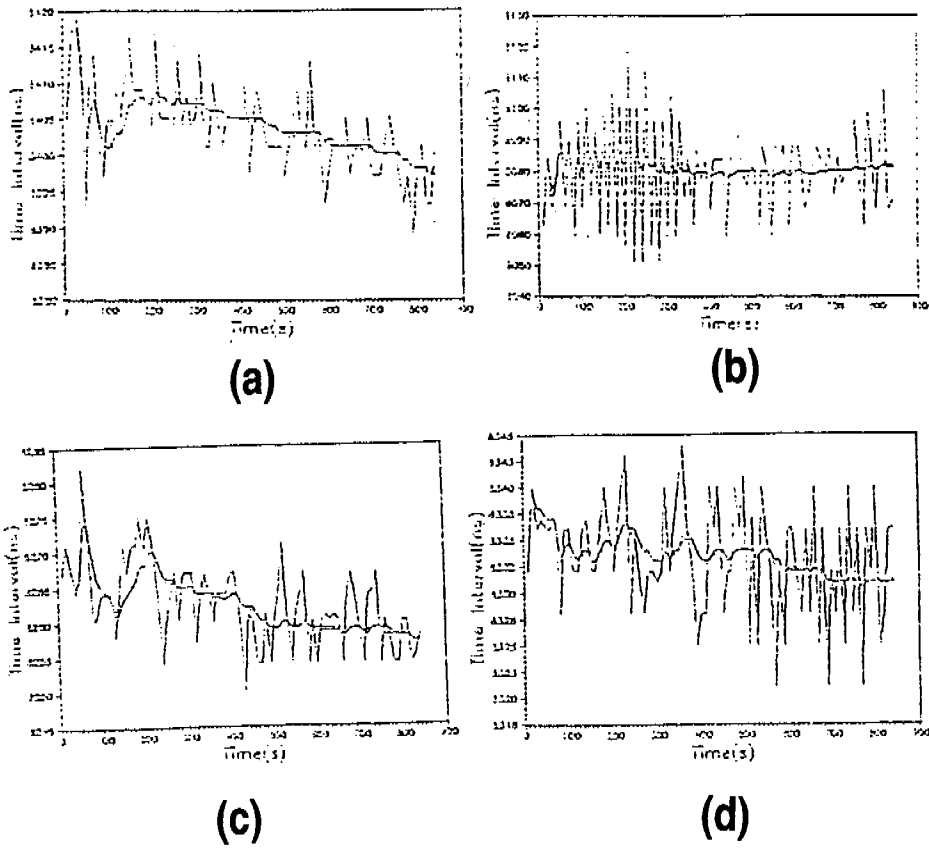

Fig.4. The Measured Curve of Data Kalman Filter Efficiency

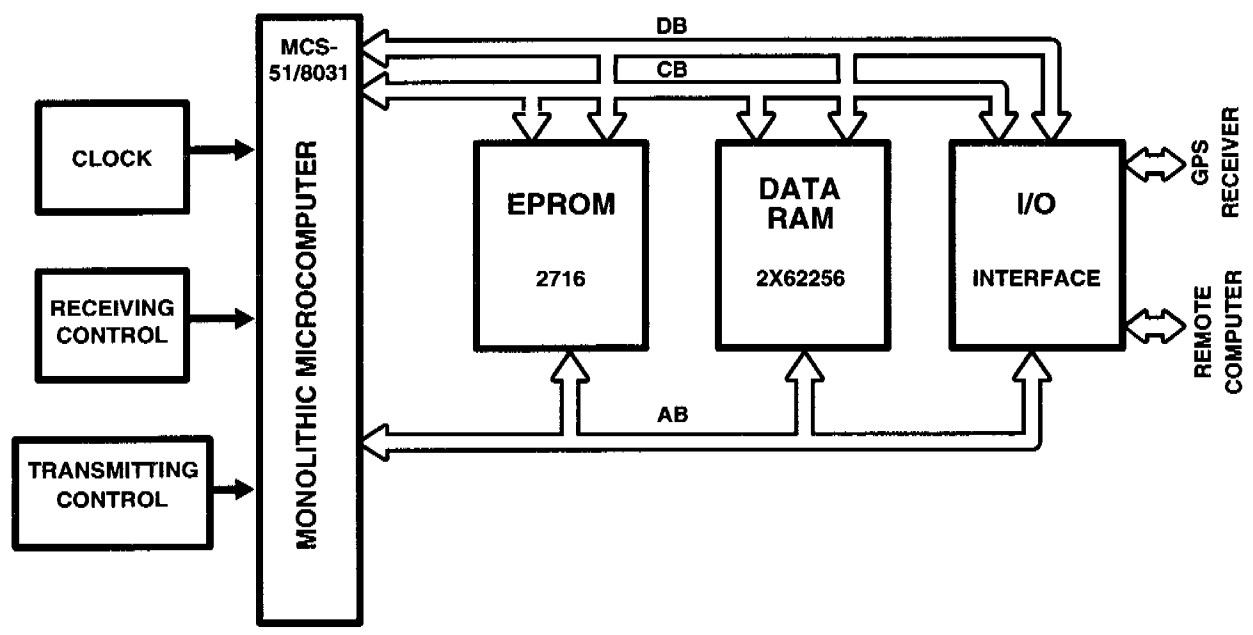

Fig. The Block Diagram of T1 Accumulator Hardware

