

TIMING SYSTEM FOR FIRING WIDELY SPACED TEST NUCLEAR DETONATIONS

Ralph E. Partridge
Los Alamos National Laboratory
P.O.Box 1663, M/S P947
Los Alamos, New Mexico 87545

The national nuclear weapons design laboratories (Los Alamos National Laboratory and Lawrence Livermore National Laboratory) test fire nuclear devices at the Nevada Test Site (NTS), which is spread over an area of over 1200 square miles (a bit larger than the state of Rhode Island). On each test there are hundreds of high time resolution recordings made of nuclear output waveforms and other phenomena. In order to synchronize these recordings with each other, with the nuclear device, and with offsite recordings, there is a requirement that the permanent command center and the outlying temporary firing sites be time tied to each other and to UTC to permit firing the shot at a predetermined time with an accuracy of about a microsecond. The system is so designed that this can be reduced to about 100 nanoseconds if it should prove necessary in the future.

New firing sites are created about every month. A year or so lead time is needed to drill and prepare each ground zero emplacement hole and its associated trailer park in the forward area. A few weeks before the nuclear device is brought in, the recording stations and trailers are emplaced in the trailer park and interconnected, and dry runs begin. By this time the trailer park timing station has been linked to the control room at the command center control point by fiber optics or microwaves. The timing station and the control room are synchronized by travelling clocks, by the communication links, and by GPS receivers. The control room can be linked simultaneously with up to four forward area sites in various stages of preparation.

Fig. 1 shows the location of the NTS and its relationship to other facilities of interest as seen from a GPS satellite. The layout of the NTS is illustrated in Fig. 2. Test area one is in the flat desert. Areas two and three are on the Pahute plateau, which is raised one to two thousand feet above the flats. In area two shots are fired in tunnels bored a mile or so northwest into the plateau. Area three is used for the larger yield shots that require greater depths of burial. Livermore fires shots in other test areas not marked on this map. In Fig. 3 we see some of the desert terrain and the results of thirty years of underground shooting. The depressions are subsidence craters where the earth has fallen in to fill the void left after a shot has vaporized and compressed the surrounding rock. Three trailer parks under construction can be seen in the background. In Fig. 4 are seen the connections between the primary facilities of the system. Timing signals are sent from the control point to the timing station by fiber optics or microwaves and thence signals are coupled to the "Red Shack" (where some of the nuclear device firing circuits are located), many recording stations, and the downhole equipment rack by coaxial cables and fiber optics. Signal waveforms come back up from detectors in the rack to be recorded in the trailers.

A typical experiment rack is shown in Fig. 5. It is about six feet in diameter and 100 feet long. The canister containing the nuclear device will be attached at the lower end, which is facing us in

this picture. Note the large number of cables attached to the upper end. The largest cranes can lift 1,000,000 pounds (500 tons). Fig. 6 shows a typical trailer park. The tower in the background is where the rack is suspended while the detectors and nuclear device are being installed. Emanating from the tower is the loop of cables that eventually will go downhole. Next to the cables is a train of carts that carry the cables to the hole during the trip downhole. The timing station and red shack are on the right side, and the microwave antennas can be seen on the short white towers.

Currently the primary time reference for the test site is maintained in an EG&G laboratory in North Las Vegas. EG&G and we collaborate in developing the time system. The North Las Vegas location is now used only for historical reasons, and we plan to move it to the control point soon. Time is obtained from NIST by common view of GPS satellites and a modem connection. NIST provides us with a monthly record of our clock's performance with a resolution of about ten nanoseconds. This time is transferred by a portable rubidium clock from North Las Vegas to the control point about 85 miles northwest. Transfer is accomplished monthly, weekly, or daily, depending on the current level of activity at the NTS. A separate GPS receiver at the control point maintains an independent check. The control point clock and this receiver continuously monitor each other, and we watch this comparison by modem from Los Alamos when we are not at the NTS.

The major components of the system are diagrammed in Fig. 7. The master clock for the NTS resides in the control room. Time is transferred from there to the forward area trailer park timing station clock either by the portable rubidium clock or by the forward area clock synchronizer (FACS). The latter equipment sends the basic one pulse per second (1 pps) signal to the forward area over fiber optics or a microwave link and measures the time required for it to be returned from the timing station. Subsequent pulses are then advanced in time and are sent out early by half of the round trip delay time so that they arrive at the timing station on time. The resolution of the time advance is twenty nanoseconds when the signals are sent over fiber optics or baseband microwave, and about 800 nanoseconds when they are multiplexed with other signals on the microwave links. The portable clock can check the setting of the forward area clock with a resolution of twenty nanoseconds. A GPS receiver is sometimes used in the timing station for an independent check.

Two of the available 1 pps sources (clock, FACS, or GPS receiver) in the timing station are chosen to be redundant trains from which a single pulse will eventually be selected to fire the nuclear explosive. Currently GPS is in disfavor for this use because its system integrity is not sufficiently assured to inspire confidence that the pulse train will not experience sudden jumps. Such jumps have indeed been observed. When the system achieves an integrity level such that the FAA will approve it for terminal area aircraft navigation, it probably will become the source of choice. An alternative may be to use two receivers that look at different groups of satellites, with an oversight circuit that requires that the independent sources agree on the time to within a suitable tolerance. This approach may be feasible as soon as a few more satellites are in orbit. Microwave channel noise could cause the FACS to generate pulses at incorrect times. For the time being this possibility is being minimized by only opening a short time window in which pulses will be accepted. On the drawing board we have a flywheel circuit to be inserted between the microwave system and the FACS interface. Both rubidium and crystal oscillators are being investigated for use in the flywheel.

In the control room the 1 pps train and standard frequencies from the master clock are sent along with an IRIG-B time code to the master signal programmer. The programmer contains a series of electrically programmable read-only memory chips (EPROMs) into which have been burned the non time critical control signals that are to be sent out for this particular nuclear test. As the countdown progresses, the signals are encoded and multiplexed and sent over the fiber optic

or microwave channels to the timing station in the forward area, where they are demultiplexed, decoded, and converted to contact closures sent to the recording stations. A number of signals also go to the red shack and perform several preliminary operations that are needed to prepare the device for firing.

Near the end of the countdown the programmer sends the fire enable signal just before the second on which the device is to be fired. This closes a relay that lets the ORed 1 pps trains pass through to the device firing circuits, and the first immediately succeeding pulse fires the device. There is a plethora of precautions, procedures, and circuits to ensure that an inadvertent firing can not take place. In addition, there are a number of interlocks in series with the fire enable line to ensure that the firing circuits and a number of the more critical recording facilities are ready. There may be an additional arbitrary delay added between the 1 pps train and the actual firing pulse. This is somewhat analogous to the Selective Availability (SA) used by DoD on the GPS satellite signals to deny their full accuracy to unauthorized users.

The largest array of equipment is used to provide more accurate timing signals to those users who require them. One of the signals emanating from the signal programmer is a countdown time code. This contains a bit stream enumerating the countdown time at the last 1 pps tick and the time for the next tick. The starting time for the countdown can be anywhere from minus a few minutes to minus 99:59, depending on requirements of the test. This countdown time code is sent to the timing station over fibers or microwaves and there it is pulse width modulated on a one megahertz carrier along with other control signals and is distributed with the 1 pps via fiber optics to the recording stations.

In each station there is a "user box" that receives the code and into which the user enters up to eight desired times for events related to recording or downhole control to occur. Typical functions that a user might want to perform are opening of camera shutters, triggering of digitizers, turning on power supplies, starting a calibration sequence, or operating downhole vacuum valves. Fig. 8 shows the front panel of a prototype unit. The countdown time and status are displayed in the upper left corner for the convenience of the operators during dry runs. In the lower right portion of the panel is where the desired event times are entered. Above it the stored times can be displayed. An in station dry run can be performed using the controls in the lower left corner, without the need for a system-wide run.

The event times are stored in nonvolatile memory with a resolution of one microsecond. As the countdown reaches each of these preselected times, its associated channel generates a selectable-width pulse, a dc level shift, and a form C relay contact actuation. The user can reprogram his choices of times up until shortly before the final dry run, but a flag is sent back to the control room when he does so, in order that the test director and control room personnel know that there have been changes made. Any channel can be used to turn off the dc level shift and contact actuation from a previous channel. This provides a start-stop mode of control for experiments that need such a capability. The user can also decide whether or not a dc level shift or contact actuation should be dropped in the event of a hold in the countdown after that particular event time has occurred.

Offsite users who are not directly connected into the timing system use GPS receivers or independent clocks to keep time. They then have their equipment continuously subtract the predicted firing time from the current time to obtain countdown time. In the event of a hold, information to update the firing time can be transmitted as time offsets by VHF radio or modems, or by ordinary telephone conversations if the remote station is manned.

At Los Alamos we maintain a time laboratory that we use in developing systems for use at the NTS. There we keep two cesium oscillators, various rubidium and crystal oscillators, GPS receivers, a countdown signal programmer, and simulated multiplexed microwave and fiber optic links.

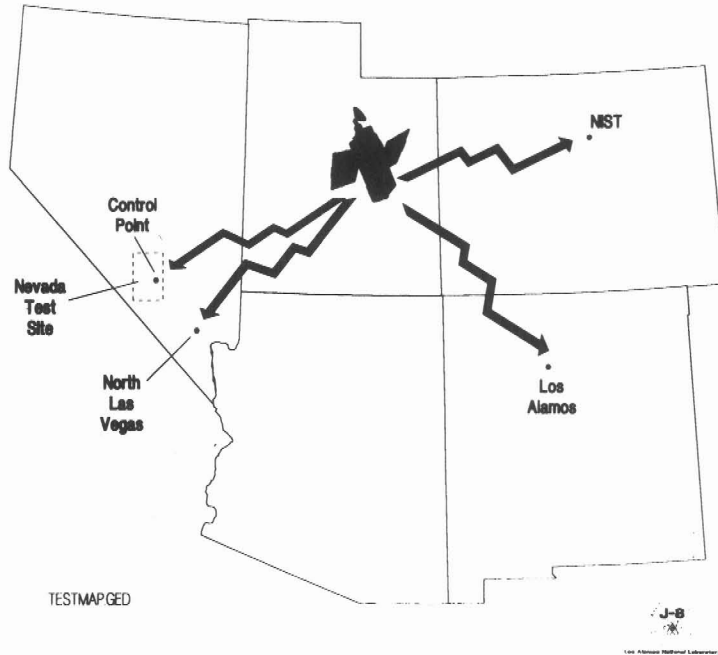

Fig. 1. Nevada Test Site and other facilities

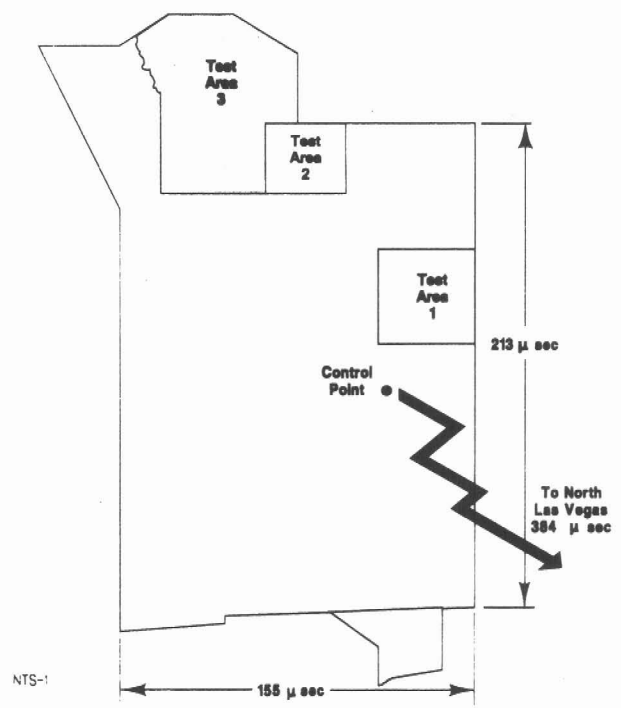

Fig. 2. Test Site layout



Fig. 3. Desert terrain with craters and trailer parks

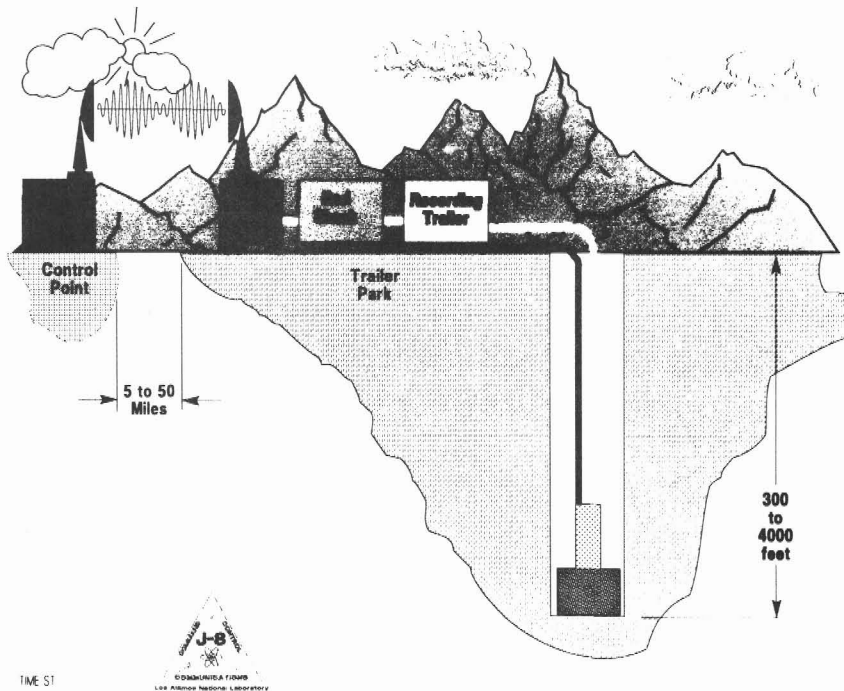

Fig. 4. Connections between primary facilities

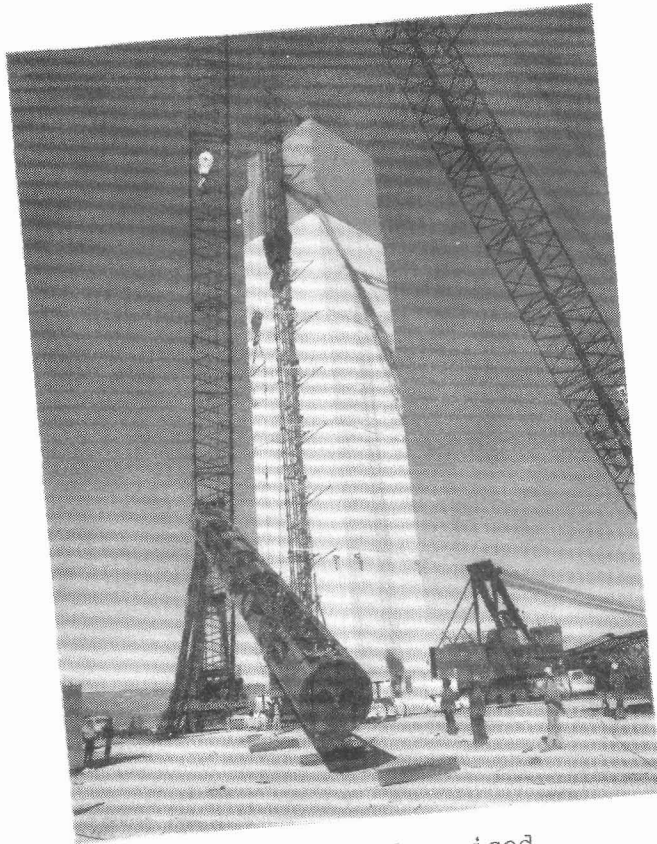

Fig. 5. Partially raised
experiment rack



Fig. 6. Typical trailer park

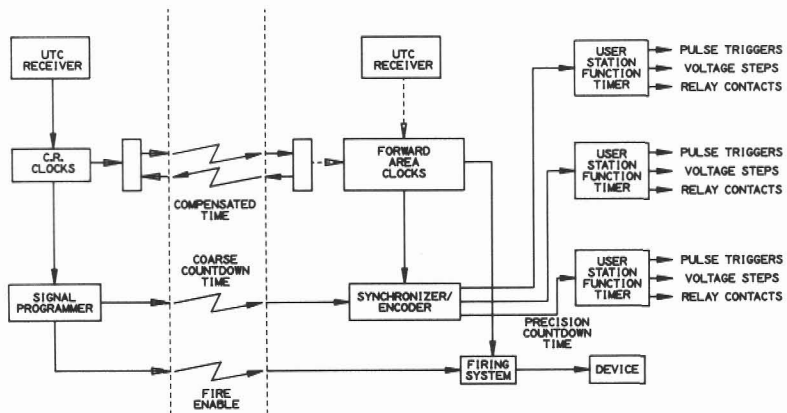

Fig. 7. Simplified system schematic

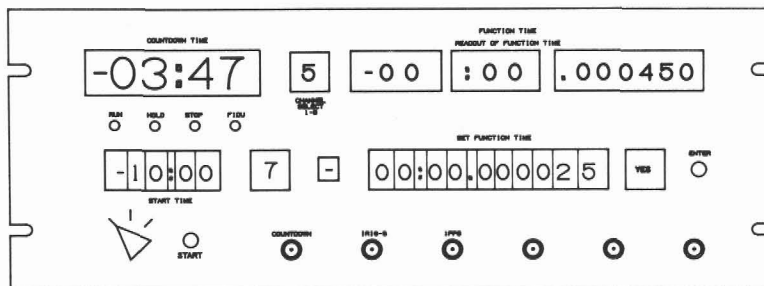

Fig. 8. Prototype user box panel