

# THE CABLE & WIRELESS APPROACH TO NETWORK SYNCHRONIZATION

Robert D. Calvert  
Cable & Wireless plc.,  
Summit House, 12, Red Lion Square,  
London, WC1R 4QD, England.

## *Abstract*

*This paper presents the philosophy adopted by Cable and Wireless for the synchronization of its world-wide network. It identifies the architectures of some of the clock systems already deployed and how network synchronization has been implemented at selected locations. This includes some innovative designs as the network spans both first and third world countries with a combination of North American and European hierarchy equipment. Different parts of the global network are linked together by a combination of terrestrial microwave, submarine cable and satellite technology. The paper also addresses the impact of synchronization on Intelsat IDR operation and the restoration of submarine cable systems.*

*The paper does not attempt to identify details of all the clock systems deployed by Cable and Wireless and its subsidiary companies world-wide, rather a snapshot of some of these systems is presented.*

## The Cable and Wireless Network

The Cable and Wireless Group is one of the world's leading telecommunications operators. The company is establishing a global digital telecommunications network connecting the world's primary economic and financial centers. Private submarine fiber optic cables link the Group's operations in Europe, North America, and the Pacific Rim via Japan and Hong Kong. In the contiguous United States, Cable and Wireless Communications Incorporated provides an all-digital broadband network which is 90% fiber optic, and within reach of 80% of the US business population. In Bermuda, Cable and Wireless has interfaced its PTAT-1 cable with another submarine fiber optic cable CARAC. The CARAC cable interconnects with Tortola in the British Virgin Islands and from there south to Trinidad via the Group's Eastern Caribbean Microwave System. This connects with most of the fourteen nations the Group serves in the West Indies.

Cable and Wireless owns and operates many satellite earth stations in locations in the Atlantic, Pacific and Indian Ocean Regions of the Intelsat system.

## Synchronization Philosophy

The Cable and Wireless Global Network is evolving into a fully digital network using Plesiochronous Digital Hierarchy (PDH) equipment. The network is split into separate regional or national networks, each of which is, or will be, synchronous at the primary rate (1544 kbit/s or 2048 kbit/s)

and below. Each Regional or National network is synchronized using the Hierarchical Master-Slave Synchronization method. Each network conforms to a network synchronization plan which has been formulated following CCITT Recommendations G.811 and G.812 (Red and Blue Books). As a result, the hierarchical clock performances comply with the following:

Level	Clock Performance Requirements		CCITT Recs	Remarks
	Drift/Day	Frequency Offset		
1	-	$1 \times 10^{-11}$	G.811	Network Reference Clock co-located with International Switching Center.
2	$1 \times 10^{-9}$	$5 \times 10^{-10}$	G.812	Co-located with National trunk exchange.
3	$2 \times 10^{-8}$	$1 \times 10^{-8}$	G.812	Local Exchanges
4	-	$5 \times 10^{-5}$	G.700	Primary rate multiplexers and Remote Line Units (RLU's)

Where the Local Exchange Clocks have a lower performance than that shown, additional synchronization links are provided to improve the availability of network timing traceable to the network reference clock. This ensures that timing performance in free-run or holdover meets the network requirements of Cable and Wireless.

This timing strategy also ensures that network timing meets the requirements necessary to achieve the end-to-end slip performance identified in CCITT Recommendation G.822, which calls for less than 5 slips in 24 hours on any 64 kbit/s connection.

Cable and Wireless have chosen to procure stand-alone reference clocks and Level 2 clocks, and to implement a Building Integrated Timing System approach to their deployment. This approach ensures independence of the synchronization system from the telecommunications equipment deployed. Additionally, it provides flexibility in expansion and avoids vendor dependence.

Each Regional or National network interworks with other regional or national networks plesiochronously. Buffers are incorporated in all equipment interfacing with international streams.

Typically, the Level 1 Reference clocks are either caesium or Loran-C based. They have an accuracy which exceeds 7 parts in  $10^{12}$  and are designed to meet an availability of 99.999%. The Level 2 clock systems are stand-alone network elements which typically exhibit a drift performance of less than 1 part in  $10^{10}$  per day in holdover, and use digital phase lock loop timing recovery circuits. Each clock system can be operated manually to support maintenance and trouble shooting.

In each network, timing is distributed downstream through the synchronization hierarchy of clocks, using the traffic carrying primary rate streams. Clock recovery occurs at each node in the hierarchy. The streams chosen for distribution of timing are direct between synchronization network elements and avoid any intermediate processing at the primary rate and below. By this means all clocks in the network are timed traceable to the Network Reference Frequency Standard (NRFS) or Reference Clock. Jitter accumulation is reduced to a minimum by using timing recovery circuits equipped with phase lock loops with very low cut-off frequencies.

Cable and Wireless has adopted a philosophy of distributing the reference clock at more than one location primarily for strategic and security reasons. This approach is designed to enhance survivability and ensure the continuance of network timing traceable to a reference clock, even during periods of catastrophic failure.

Each clock sub-system is a hybrid Level 1 and Level 2 clock. At any point in time, only one of the sub-systems provides the network reference (Level 1 operation), the other sub-systems recover timing from incoming primary rate streams clocked from the reference sub-system's location (Level 2 operation). The architecture of a sub-system is as shown in Figure 1.

Control of this distributed reference clock system has been effected in two ways. Some of the systems already deployed use telemetry over modem channels, others utilize telemetry embedded in the primary rate frame.

The system deployed in the Eastern Caribbean Network makes use of the 2048 kbit/s primary rate frame structure. This has a number of spare bits available for use by the network provider. These are located within time slot zero of the frame not containing the frame alignment word. The system consists of three sub-systems, each being a hybrid Level 1 and 2 system. The status of each sub-system is signaled to the other two sub-systems using the spare bits.

The system deployed in Hong Kong has two sub-systems which communicate their status to each other over a modem channel. This philosophy is also being adopted for the system being deployed in Jamaica. The reason for this is that the Jamaica network is based on the North American digital hierarchy and there is no available integral telemetry facility embedded into the 1544 kbit/s standard frame structure at this time. (See below for Facilities Data Link).

A Loran-C based reference clock has been operating in the Bermuda network for three years without loss of timing. A fully redundant clock architecture is employed using the configuration shown in Figure 2. Two Loran-C receivers lock to different Loran chains and can automatically acquire a third chain if any of the selected chains fail. A similar system will shortly be installed in the Cayman Islands.

Each Level 2 clock has a fully redundant architecture with a configuration as shown in Figure 3. The timing recovery systems have selectable time constants, thereby allowing the phase lock loop cut-off frequency to be adjusted to optimize jitter and wander rejection. They have a capture range of 3 parts in  $10^7$ . In holdover mode they can provide G.811 compatible performance for 10 hours or longer. This means that disruptions to the synchronization distribution network are transparent to the telecommunications traffic being carried by the network.

Cable and Wireless have adopted an approach of quality-marking 2048 kbit/s primary rate streams used to distribute synchronization. Such streams are at present marked to indicate traceability to the reference clock. Loss of traceability results in a simple bit flip from the 0 state to the 1 state. The bit chosen for this is bit 5 in time slot zero of the frame not containing the frame alignment word.

For networks based on the North American digital hierarchy, the 1544 kbit/s extended frame super-frame can be used to provide this facility. There is a 4 kbit/s data channel in this frame structure, and specific code words may be standardized for synchronization use. Although not available at present, the "facilities data link" will be used if it meets Cable and Wireless requirements.

For example, in the Eastern Caribbean Network, the timing quality of the stream is signaled to indicate whether it is traceable to caesium or not. Each of the Cable and Wireless operated islands in the network have a slave clock, which is able to interrogate each synchronization stream and lock to whichever indicates its timing is traceable to the network reference.

Cable and Wireless operates the telecommunications of a number of small island nations where the only international routes are via the Intelsat satellite system. Typically, these systems now conform with the Intelsat Earth Station Standard (IESS) 308, which details the performance characteristics for Intermediate Data Rate (IDR) digital carriers. Where the location offers only analog services (Voice or voice band data) the IDR equipment is loop-timed to the distant end where a double Doppler buffer is employed on the receive equipment to absorb the Doppler delay variation. However, where the location operates a direct digital service, via IDR, to more than one destination, there is a need to provide a cost effective reference clock to meet the network's synchronization requirement. The solution may come in the form of a low cost GPS-based system, or alternatively a slave standard approach. In the latter case, it may be possible to extract and average timing from a number of IDR streams of known quality and drive a quartz standard to emulate the performance requirements imposed by CCITT Recommendation G.811.

Successful IDR operation requires an acceptable slip performance for the satellite section. The Doppler/plesiochronous buffer found within the IDR equipment must be clocked out by a clock traceable to a G.811 compatible reference. A typical configuration is shown on the attached drawing, Figure 4 (lower half). Here the clock is recovered from the 'transmit to satellite' stream (within the IDR equipment), and used to clock out the 'receive from satellite' stream from the buffers. However, some IDR modems are unable to perform this function and require a separate external clock input to the buffer. All digital streams at the primary rate and below are timed traceable to the reference clock. Therefore, the slip performance for a 2048 kbit/s or 1544 kbit/s primary rate IDR path will be of the order of 1 slip in 70 days.

Higher order multiplexers, such as the hybrid 2 Mbit/s to 45 Mbit/s multiplexers used in the transmission system, shown in Figure 4 (lower half), are not normally required to be timed traceable to the reference clock. These higher order multiplexers operate timed from their own internal quartz oscillators. These oscillators operate at a higher frequency than the combined aggregate tributary frequency and employ a technique known as bit stuffing or justification to maintain tributary synchronism. This ensures that the timing of the tributary stream is maintained transparent to the higher order multiplexer.

For restoration of a cable system it is more efficient to be able to restore at the highest bit rate, this is currently being performed at 45 Mbit/s. At the 45 Mbit/s rate, it is essential that the higher order multiplexer transmitting the 45 Mbit/s aggregate stream is timed traceable to the network reference clock (see Figure 4 upper half). Failure to do this will make the slip performance on the satellite section unacceptable. The reason for this is that within the higher order multiplexer the internal quartz clock has an accuracy of 20ppm. If this multiplexer is not externally timed the resulting slip performance may be as bad as 1 slip every 3 seconds. Additionally, because the frame of the 45 Mbit/s aggregate stream bears no relationship to the frame structure of the 2 Mbit/s tributary streams it transports, every slip at the 45 Mbit/s level will result in a re-frame at the 2 Mbit/s level.

To achieve acceptable slip performance during the period of cable restoration, the 2 Mbit/s to 45 Mbit/s higher order multiplexer feeding the 45 Mbit/s IDR modem must be timed from the reference clock. Cable and Wireless has achieved this by equipping clock systems with 45 MHz clock interfaces and feeding this to the external clock input of the multiplexer. This ensures that the 45 Mbit/s 'transmit to satellite' bit stream has acceptable timing. If the buffers within the IDR modems are centered at the start of the restoration period, they should not slip during the likely period of restoration; this is unlikely to last for longer than 15 days. All parties participating in a cable restoration via satellite must ensure that their 'transmit to satellite' streams are timed as shown in Figure 4 (Upper half).

Cable and Wireless wholly own or have capacity in a number of submarine cable systems. Some examples of wholly-owned systems are the Private TransAtlantic Cable, PTAT-1, and the Bermuda to Tortola cable, CARAC. Efficient restoration via satellite for such systems is of paramount importance.

The clock systems deployed in the Cable and Wireless network continue to operate satisfactorily. The Bermuda Loran-C system has operated fault-free since its installation in 1987. The reception of the Loran-C signal has been interrupted to one receiver during a very heavy rain storm on one occasion only. However, the fully redundant clock system architecture proved robust enough to maintain the timing signal outputs traceable to Loran-C continuously during this period. The quality of the timing signal output has been periodically compared with that from a portable caesium and found to be at least as accurate.

The distributed caesium-based Eastern Caribbean Clock System has operated satisfactorily since its installation in 1989. The system is designed to measure both phase and time interval error (TIE) between its own internal caesium reference and the streams passing through it. TIE is measured in consecutive time periods using windows of duration of 100, 1000, and 10000 seconds. Phase is measured as a running total and so can be analyzed to give MRTIE over an extended period. The alarm system flags a TIE alarm on any stream which exceeds the CCITT Rec. G.811 mask.

The result of measurements in Tortola indicate that the MRTIE between the Cable and Wireless network and the AT&T timed streams passing through St. Thomas in the US Virgin Islands are within the CCITT Rec. G.811 mask. The MRTIE between Barbados, Antigua and Tortola, where the reference clock sub-systems are located, are within the resolution of the system. The system is consequently performing exceptionally well and indicates that the complete network is solidly synchronized.

The distributed caesium-based system installed in Hong Kong Telecommunications' network is based on a two sub-system clock with one sub-system installed on Hong Kong Island and the other in Kowloon. The MRTIE measured between the two caesiums is of the order of 2 parts in  $10^{12}$ . The system has operated satisfactorily since its installation in 1987. Again the system is equipped to measure both TIE and phase.

Figure 1 DISTRIBUTED REFERENCE CLOCK SUB – SYSTEM

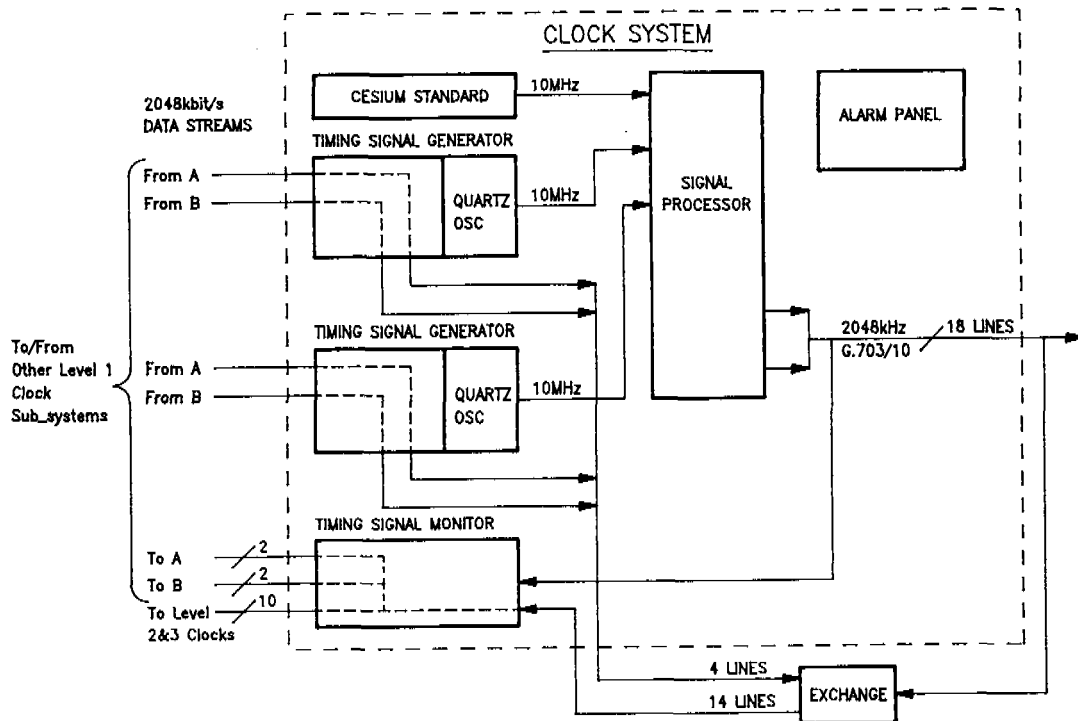

Figure 2 BASIC BLOCK DIAGRAM FOR LORAN – C BASED REFERENCE CLOCK

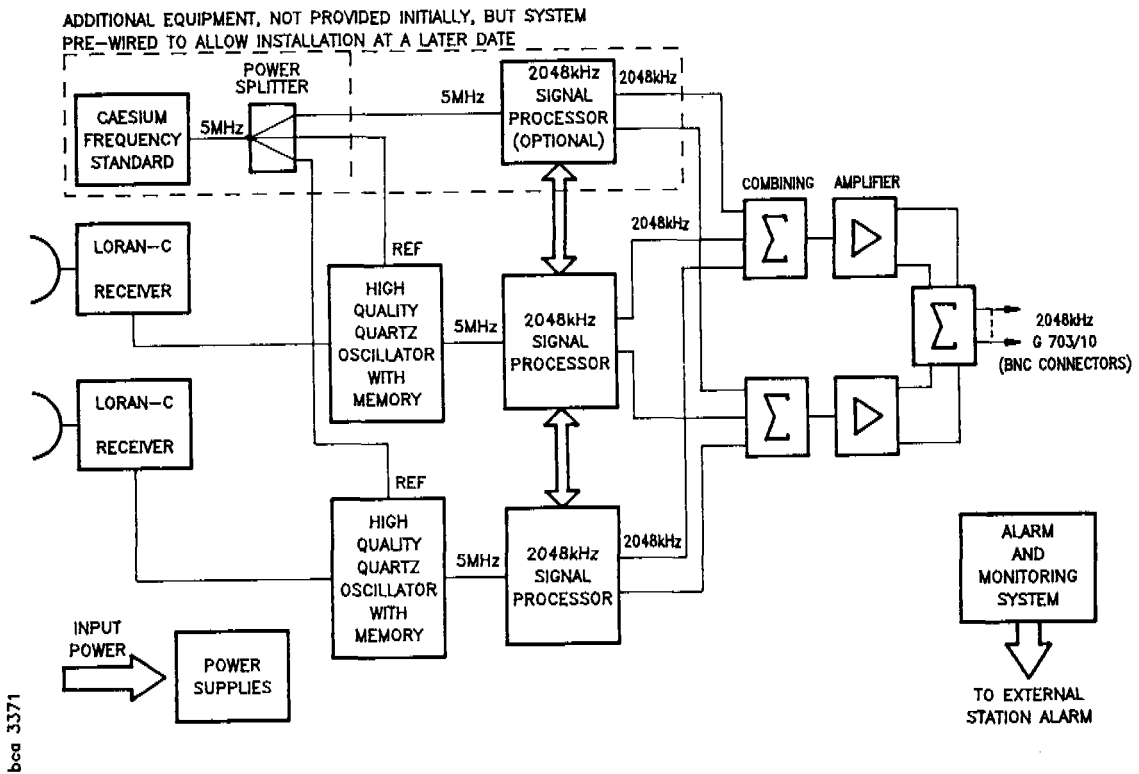

Figure 3 LEVEL 2 SYNCHRONISATION SYSTEM

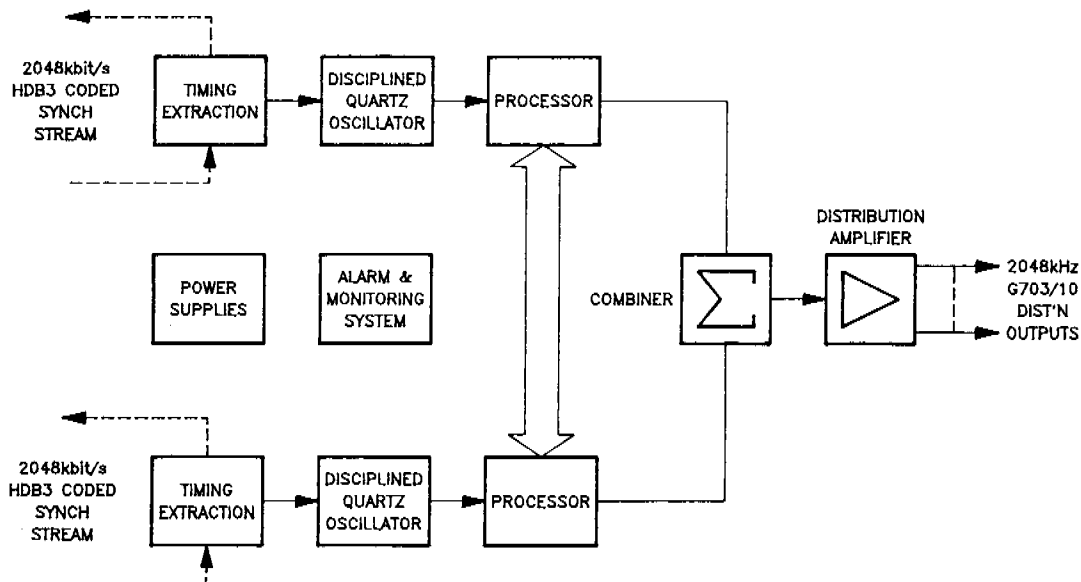
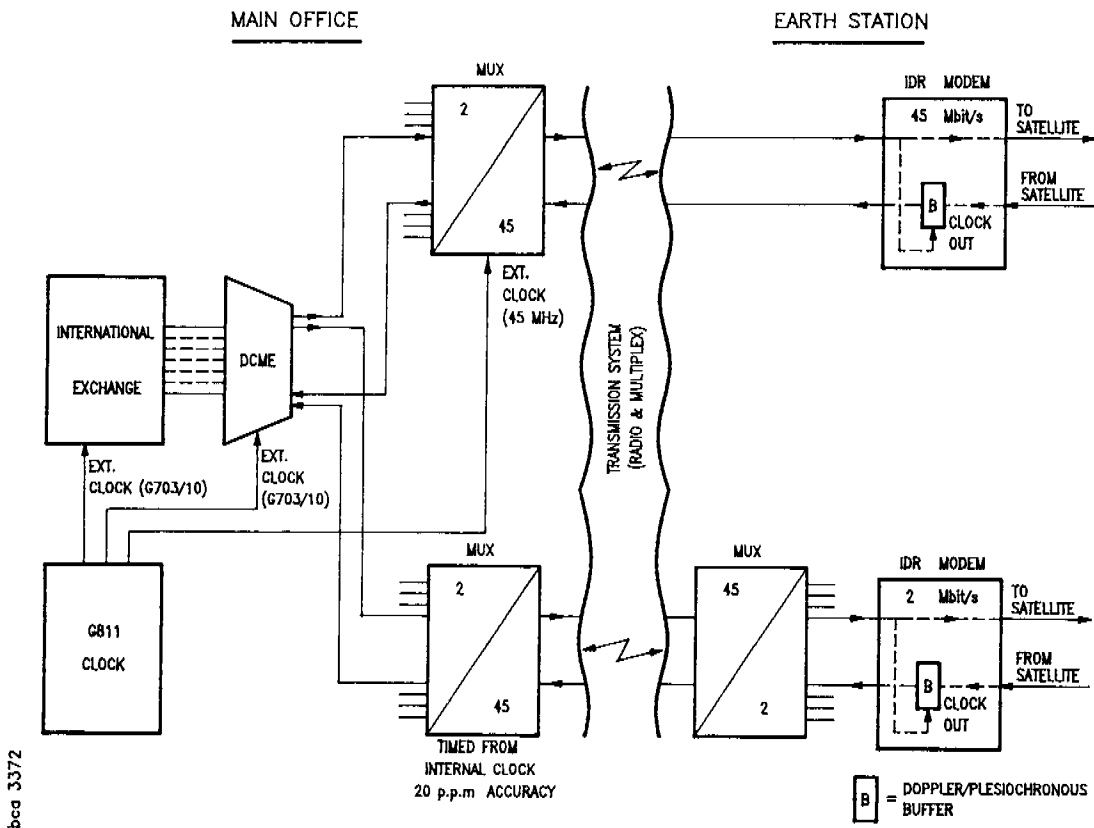

Figure 4 IDR OPERATION INCLUDING CABLE RESTORATION VIA SATELLITE



bca 3372

# QUESTIONS AND ANSWERS

**Unidentified Questioner:** Have you measured the availability that you got out of your LORAN system?

**Mr. Bodily:** The only system that we have had running for any length of time is our system in Bermuda, which is LORAN based. Out of the three years that we have had the system in operation, we have had one occasion where we lost the signal, and that was due to a heavy rainstorm. Apart from that, there have been no outages. Almost 100% availability.

**Unidentified Questioner from MCI:** When the processor makes the choice between those input references, is that purely based on the quality marker?

**Mr. Bodily:** No. In the Level 1 system the quality markers tend to be ignored. The signal processor will measure the error between the outputs of the two oscillators, or each oscillator and the cesium standard. The quality marker is really for use in the Level 2 and Level 3 clocks. It gives a direct indication as to whether the cesium has actually failed.