

DESIGN AND INDUSTRIAL PRODUCTION OF FREQUENCY STANDARDS IN THE USSR

N.A. Demidov and A.A. Uljanov
"QUARTZ" Research and Production Association

Abstract

Some aspects of research development and production of quantum frequency standards, carried out in "QUARTZ" Research and Production Association (RPA), Gorky, USSR, have been investigated for the last 25–30 years. During this period a number of rubidium and hydrogen frequency standards, based on the active maser, have been developed and put into production. The first industrial model of a passive hydrogen maser has been designed in the last years.

Besides frequency standards for a wide application range, RPA "QUARTZ" investigates metrological frequency standards — cesium standards with cavity length 1.9 m and hydrogen masers with a flexible storage bulb.

HYDROGEN MASERS

The first hydrogen maser industrial model CH1-44 was developed in 1968. It was a bulky facility with ion pumps and a glass ceramic cavity. This maser frequency stability was better than 5×10^{-13} per day. Thanks to these early instruments the company has got an experience to work with hydrogen masers, it has investigated their behavior, defined the requirements to maser main units and made technological base for their commercial production. Totally 10 units of this type were produced.

The second hydrogen maser model CH1-70 was designed in 1974. Its metrological and operating characteristics were significantly improved: it decreased dimensions and weight, frequency stability better than $(2 \text{ to } 3) \times 10^{-14}$ per 100 s to 1h measurement intervals. The maser view is shown in Fig. 1, and its schematic structure is given in Fig. 2. The design peculiarity is a special 3-section ion pump, that separately evacuates the storage bulb, state selector magnet and cavity. A separate storage bulb and cavity vacuum system complicate the maser design, but due to this a better vacuum in the storage bulb is achieved. Our experience showed that the wall shift stability and residual gas level in the storage bulb could be correlated. The maser vacuum system uses all-metal seals.

Cavity mechanical resistivity to shocks, vibrations, and stress relaxations significantly influence the hydrogen maser parameters. Our investigations allowed us to solve a number of design and technological problems that reduced these factors to 10^{-15} . Particularly, in masers of this type, frequency dependence on external pressure was 1×10^{-15} per 50 mm Hg.

The cavity frequency drift is the most critical factor in long-term measurements. It was of order $(+1.5 \text{ to } +3) \times 10^{-13}$ per day for CH1-44 model and had a tendency to continuous decrease with time. It proved to be related to thermodynamic equilibrium achievement in cavity material. The

drift value in masers with glass ceramic and fused quartz cavities largely depends on oven operating temperature and previous cavity thermal processing. The special thermal processing technology for the CH1-70 maser cavities, made of S0-115M astroglass ceramic, allowed us to minimize the frequency drift down to $< 1 \times 10^{-14}$ per day in the majority of the instruments.

Storage bulbs are coated by fluoroplastics (teflon). They are more insensitive to atomic hydrogen and provide a less spectral line shift and a broadening. For this purpose, until 1975 in the USSR fluoroplastic suspension F-4(tetrafluoroethylene homopolymer) was used, providing a frequency shift of -0.034 Hz for bulbs with 15.7 cm in diameter at temperature $+50$ °C. As it was found, the wall shift and the spectral line Q factor greatly depend on smoothness of polymer surface structure. Further progress was noted, when fusible fluoroplastics were offered for bulb coating. The best results were received from fluoroplastic F-10, that provided the frequency shift -0.005 Hz and $Q \approx 2.5 \times 10^9$ ^[1].

CH1-80 frequency standard represents this maser modification; it has improved electronics and is produced by "QUARTZ" RPA up to now. The basic instrument characteristics are shown in Fig. 3. The company has delivered 150 instruments on the whole, and all of them are actually operating, thanks to our maintenance and repair service.

These instruments are actively used by the National Time and Frequency Service, they proved to be useful in Very Long Baseline Interferometry, etc. Time and frequency references, located in European and Asiatic parts of the USSR, are based on these instruments^[2].

Today we have extensive statistical data, confirming maser high long-term frequency stability in automatic cavity tuning mode—systematic frequency drifts are less than 1×10^{-13} per 1 year. According to National Scientific and Research Institute for Physical, Technical and Radiotechnical Measurements (VNIIFTRI), the measurement data, taken in January–May interval of 1990, the frequency drift of four CH1-80 instruments was less than 1×10^{-16} per day^[3].

The instruments of this type, operating in automatic cavity tuning mode with digital system, have lifetimes of 3 years and more. In this mode the atomic beam intensity is modulated. When the automatic cavity tuning system is switched off, the beam intensity decreases and the instrument lifetime is not less 5 years. The main limiting factor of lifetime is the ion pump, and — very seldom—the discharge bulb of atomic hydrogen source made of quartz glass. The ion pump lifetime can be increased by titanium pump plates replacement.

The CH1-75 frequency standard is the last model of this family, released in 1986. Its maser, given in fig.4, has $480 \times 550 \times 680$ mm dimensions and weight 90 kg.

The sorption pump design with titanium compact chip as a getter allowed the increase of reliability and lifetime of the beam-forming system with simultaneous weight, dimension and power consumption decreasing. The use of titanium chip excludes maser vacuum system contamination due to getter destruction at continuous operation for long periods. In this case sufficiently large getter particles form a fine grid^[4]. The sorption pump external view is shown in Fig. 5. The sorption pump contains about 1 kg of getter, that provides the instrument lifetime for over 5 years. The pump is equipped with the tungsten heater. The chip surface is activated at 800 °C temperature and vacuum better than 10^{-15} mm Hg. Gases not absorbed by the getter can be pumped out by a small ion pump with (1-2) l/s productivity. The similar pump provides vacuum in the microwave cavity.

The small distance between the selective magnet and the storage bulb makes the task of creation an effective selective system more difficult. Quadrupole and hexapole magnet efficiencies were also investigated. As a result, we used quadrupole magnet with its length-to-channel diameter ratio 40.

The magnet had an external diameter of 30 mm, a channel diameter of 1.6 mm, and a length of 75 mm. The magnetic induction on the pole tips is 1 T. The atomic hydrogen source is made of a superpure quartz glass. Its structure is given in Fig. 6. Vacuum seals are provided by indium gaskets, located directly on the source glass flange and fixed by a nut, made of springy bronze. The multichannel collimator is made of a Pyrex glass. Channel diameter is 0.01 mm, the external diameter is 0.5 mm, and the length is 0.8 mm. The compound LaNi_5H_x is used for keeping molecular hydrogen. The LaNi_5H_x is characterized by high hydrogen partial pressure (2 to 5 atm) at $+(20-50)^\circ\text{C}$. 250 grams of the compound contains 18 liters of hydrogen at normal pressure. It is sufficient for maser continuous operation for more than 40 000 hours.

The multizone two-stage oven has the temperature control factor 10^4 . The instrument temperature coefficient of frequency is less than $5 \times 10^{-15}/^\circ\text{C}$.

Magnetic field stabilization in the storage bulb area is provided by a five-layer 81 HMA permalloy shield of 0.35 to 0.5 mm thickness. The shielding dynamic factor of the system with 5 magnetic shields is of order 3×10^4 . For the further increasing of a shielding factor a system of "active" magnetic field stabilization was developed^[5], where a ferroprobe is used as a sensitive element. With the help of this "active" stabilization system the shielding factor over 10^5 is achieved.

Crystal oscillator frequency tuning to spectral line frequency is accomplished in the automatic frequency control unit, having an ordinary block-diagram. The large multiplication factor for the first multiplier stages and optimal operating modes for all assemblies allowed us to minimize the common phase temperature coefficient of the automatic frequency control unit to $0.01\text{ ns}/^\circ\text{C}$. It permits the achievement of maser frequency stability 10^{-15} without temperature control of the AFC unit.

The instrument has a built-in frequency comparator, providing frequency and phase comparison, and also manual and automatic cavity tuning when a reference signal with characteristics similar to a maser is used. Current time indication and assembly diagnostics are performed with the help of the control unit, containing a reversible frequency counter, a control assembly, and a digital-to-analog converter.

The 5 and 100 MHz output signal frequency stability of CH1-75 is $(2\text{ to }3) \times 10^{-13}$ per s and lowers to $(1\text{ to }2) \times 10^{-15}$ per 10^3 to 10^4 s measurement interval. With automatic cavity tuning system in operation, the frequency stability is equal to $(2\text{ to }3) \times 10^{-15}$ per day. Presently this instrument is in serial production.

PASSIVE HYDROGEN MASER

From early days of hydrogen standards and up to now much attention has been paid to problems of improving hydrogen frequency standard characteristics, concerning their weight and dimensions, operation in severe conditions, as these standards can be used in modern global navigational systems and in transportable clocks for time scale synchronization with nanosecond accuracy. Due to new materials, technical decisions and vacuum facilities hydrogen maser dimensions depend on microwave H_{011} -mode cavity size with height and diameter about 280 mm.

The major decision for minimizing dimensions and weight of a hydrogen frequency standard can be found in decreasing microwave cavity size. However, it leads to lowering its Q-factor, impossibility of self-excitation, and as a result the maser can work only in amplification mode—that is, the quantum discriminator mode. The idea of spectral line indication by detecting a frequency-modulated

signal passing through the microwave cavity, promoted the creation of small-sized hydrogen frequency standards^[6]. In addition to minimizing the instrument size, hydrogen maser passive mode of operation improves a long-term stability and a lifetime due to atomic beam intensity reduction.

The quantum hydrogen discriminator uses two types of small-sized cavities with quasi- H_{011} modes: cavities with partial dielectric filling^[7] and the so-called special axial-symmetric (SAS) cavity with metal plates around the storage bulb, intended for use in hydrogen masers^[8,9].

Metal-dielectric cavities have a rigid construction, capable of resisting extremely high levels of shock and vibration, but the lack of industrial production in USSR, high cost and processing difficulties limit the application of industrial instruments. This was the reason to choose a SAS-cavity for the industrial instrument, that is more simple in production and where less expensive materials can be used.

The main problem at SAS-cavity development was to design a rigid construction of metal plates, isolated from cavity walls, as was proposed in [8,9]. We tested different methods of metal evaporation, paste burning-in on a quartz storage bulb, fine metal strips gluing and so on. But these techniques did not give good results. The first two methods showed a low cavity Q-factor of 4×10^3 . The third one did not provide sufficient construction reliability, due to different thermal coefficient for quartz glass and metal. The problem was solved by the developing of the original cavity construction^[10], where plates were attached to the cavity face walls by metal non-isolated jumpers. The cavity structure is manufactured simultaneously with the cavity base and is characterized by sufficient rigidity, high Q-factor and good producibility.

The offered SAS-cavity design is used in CH1-76 passive hydrogen maser (Fig.7). The cavity is made of D16 aluminum alloy with silvered walls and has a Q-factor of 12×10^3 and internal diameter of the cylinder of 128 mm and of the plates of 62 mm. This provides amplification over 8 dB. The storage bulb, coated by fluoroplastic F-10, has a relatively small volume 0.45 l, in this case spectral line Q-factor can reach 1×10^9 . The cavity is surrounded by four magnetic shields. The three internal shields are made of permalloy 81HMA of 0.5 mm thickness. They are placed in vacuum, and additionally perform the function of heat reflecting screens.

The fourth magnetic shield is made of 79HM permalloy of 1 mm thickness. It shields completely the discriminator and represents a load-carrying structure. The shielding dynamic factor is more than 8×10^4 . The atomic hydrogen source located in the fourth magnetic shield, has a ring-shaped magnet, providing continuously variable magnetic field configuration in interdrift space. This prevents a Zeeman sublevel population change. Besides, the magnet improves HF discharge operating mode. The quantum hydrogen discriminator oven has a stage with two independent control zones. The oven heater windings are located at the external cavity side. Total power dissipated by the ovens is equal to 1 W at normal conditions and cavity temperature of 50°C. The quantum hydrogen discriminator is made in the form of tube with 222 mm in diameter, 520 mm in length and 19.5 kg in weight.

The construction of the above-mentioned cavity with relatively thin and long jumpers is not enough resistant to shocks and vibrations. This disadvantage is eliminated in our "magnetron" construction of the SAS-cavity^[11]. Here metal plates are fixed to the lateral surface of the cavity, manufactured from a monolithic piece, that provides its high mechanical rigidity and reliability (Fig. 8).

The short-term frequency stability of the passive hydrogen frequency standard depends on conversion transconductance (figure of merit) of the quantum hydrogen discriminator, and its long-term stability is determined by spectral line stability and AFC system accuracy. The limiting factors for long-term spectral line stability are the same as for an active maser, and they permit the achievement of high

metrological characteristics.

The CH1-76 passive hydrogen standard block-diagram (Fig. 9a) was designed on the base of the block-diagram for one modulation frequency, offered in article [12]. The advantage of this diagram is in use of "noise" local oscillator, that eliminates the influence of spurious signal, passing from 20.405 MHz synthesizer to the IF amplifier channel^[13]. In the passive hydrogen standard a separate crystal oscillator with 90MHz frequency, multiplied up to 1440 MHz, is used as a local oscillator of this type.

Usually the CH1-76 frequency stability is determined by the expression $\sigma = 1 \times 10^{-12} / \tau^{1/2}$ at $1 < \tau < 10^4$ s. Frequency stability is equal to 1×10^{-14} per day and is limited by transients in electronic assemblies. Further improvement of electronic assemblies gives us a hope to reach frequency stability for the specified quantum hydrogen discriminator of $(3 \text{ to } 5) \times 10^{-15}$ per day. The temperature coefficient of frequency is less than $2 \times 10^{-14} / ^\circ\text{C}$. Frequency shift at magnetic field variation in the range of $\pm 2 \times 10^{-4}$ T is less than $(3 \text{ to } 5) \times 10^{-14}$. The CH1-76 frequency standard is characterized by a good long-term frequency stability. For measurement intervals of several months the frequency drift is $(1 \text{ to } 3) \times 10^{-16}$ per day (Fig. 10)^[14].

The CH1-76 frequency standard has a satisfactory mechanical rigidity and maintains high metrological characteristics under severe mechanical conditions. It was proved by its tests as transportable clocks. The standard dimensions are 280×480×555 mm (height, width, depth), a weight of 53 kg, power consumption of 70 W from +27 V power supply (Fig. 9b).

HYDROGEN MASER WITH FLEXIBLE STORAGE BULB

The absolute frequency of the hydrogen maser is generally determined by a wall-shift measurement accuracy. Nonreproducibility of coating characteristics in the traditional method of wall-shift measurement gives an accuracy of $(1 \text{ to } 2) \times 10^{-12}$. The further improvement of the wall shift measurement accuracy can be achieved by the design of a hydrogen maser with a flexible storage bulb. Its use eliminates basic limitations in accuracy measurement, as the same bulb surface is present during the measurements at bulb volume change. The use of a flexible storage bulb allows us to control a wall shift during its operation. In its turn it permits the increase in long-term frequency stability of a hydrogen maser. Many authors attempted to develop a hydrogen maser with a flexible storage bulb, but because of great manufacturing problems they failed.

As a result of our tests we came to the conclusion, that the construction with the flexible storage bulb part outside the microwave cavity is preferable. The optimization of the storage bulb shape and size allowed us to achieve the characteristics of the hydrogen maser with a flexible bulb similar to CH1-70 standard specifications. The problem of the bulb volume reproduction with high accuracy was solved by reinforcing its flexible part with a quartz or aluminosilicate glass cloth^[15]. The hydrogen maser design with a flexible bulb, developed in 1985, is shown in Fig. 11.

Starting from 1986 continuous measurements are taken. During this period the quantum hydrogen maser with a flexible bulb showed a high reliability. The bulb volume was changed more than one hundred times and no changes were noticed in the flexible part. The frequency measurement of the hydrogen maser with the flexible storage bulb and its volume change gave us the opportunity to determine a hydrogen atom nondisturbed transition frequency with high precision.

The test results are summarized in Table 1.

		Table 1.		
Coating material	Wall shift, Hz at 50°C D=15.7 mm	Bulb number	f=1420405751 Hz	Data reference, year
F-4DU	-0.0242 ± 0.0014	10	,,,.7682 ± 0.0014	[18], 1976
F-4D	-0.034 ± 0.004	6	,,,.77 ± 0.005	[19], 1977
TFE-42	-0.0337 ± 0.001	11	,,,.768 ± 0.002	[20], 1970
FEP-120	-0.022 ± 0.001	6	,,,.77 ± 0.003	[21], 1971
F-10		flexible bulb	,,,.709 ± 0.0005	1988

The received frequency value $f_0 = 1420405751.7709 + 0.0005$ Hz is in good agreement with f_0 measurement results, received by bulb replacing method. We hope to improve a wall shift and f measurement accuracy to better than 1×10^{-13} by the further flexible bulb modification, a better bulb volume control, a more pure and uniform bulb coating and the test accuracy of order 10^{-15} .

RUBIDIUM FREQUENCY STANDARDS

The concept of rubidium standard design was adopted in the 1970's and includes two trends:

- rubidium frequency standards,
- measuring rubidium frequency and time standards.

The first trend represents the commercial rubidium standards CH1-43(1968), CH1-50(1971), CH1-72(1981), CH1-77(1987). The second trend includes the instruments, which are used by metrological services of industrial plants. The instruments of this type are CH1-48(1971), CH1-69(1976), CH1-78(1987). At present time three models of rubidium frequency standards are produced: CH1-78, SCHV-74 and RSCH-77 (Fig. 12). The instruments have traditional block-diagrams, but the design and manufacturing technology of the rubidium quantum discriminator are original and asserted by certificates of authorship. It refers to optical pump source design with a cylindrical gas-discharge tube, located in an evacuated bulb (Fig. 13).

This design decision provides low power consumption (700-800 mW), and allows placement of the quantum elements (absorption cells, filters, pump source) in one temperature-controlled volume. It provides low temperature coefficient of frequency for the instruments.

The tests showed, that the basic aging process of the gas-discharge tube can be explained by surface conductance, caused by the influence of HF discharge plasma on glass surface when alkali metal vapor is used. In its turn it creates a systematic frequency drift due to a light beam shift and shortens the lifetime of the gas-discharge tube. To decrease the influences of these factors, the rubidium

standard utilizes the reduction mode. When the instrument is turned on, the gas-discharge tube is warmed up in a short time up to the temperature (200-250)°C. The conductive film, formed on the internal tube surface, is broken and gas-discharge is ignited in the normal way. The reduction mode allowed us to increase a gas-discharge tube lifetime and improve the metrological parameters of the rubidium standard. The original manufacturing technology of quantum elements is characterized by the absorption element material (rubidium-87 and potassium alloy, filled with argon under 1 mm Hg pressure), by buffer gas pressure calibration technique in an absorption cell according to signal frequency offset of atomic resonance (calibration accuracy (3 to 4) × 10⁻¹¹ and some other technical decisions. All of them provided sufficiently high metrological characteristics of the rubidium standard and its stability under hard environmental and mechanical conditions.

The rubidium standard production is provided by complete special technological equipment, developed and manufactured by domestic plants.

The main specifications of CH1-78 standard are given in Table 2.

METROLOGICAL CESIUM FREQUENCY STANDARD

In 1980 RPA "QUARTZ" developed the MC-3 cesium frequency standard for National time and frequency state service^[17].

The cesium atomic beam tube (Fig. 15) consists of Ramsey microwave cavity with drift space length 194 cm and interaction area length of 1 cm each, transverse field H_c, formed by four bars, a three-layer magnetic shield (internal rectangle), two mobile source-detector units (one at each side of the atomic beam tube), and two-pole selective magnets. All of them are enclosed in a vacuum system, evacuated by two 250 l ion pumps (vacuum 5 × 10⁻⁶ Pa).

The beam is of ribbon type, formed by multichannel collimator with transversal dimensions 9×0.5 mm. The beam optics uses selective magnets with a center slot and valves, placed across the beam center. The center beam frequency of Ramsey resonance can reach (48-65) Hz depending on the light source and the detector position. The field strength is of the order H_c ≈ 5.25 A/m. The maximum field nonuniformity is 0.5%, it is tested by eight Zeeman coils, located along the beam axis. The used signal makes up 80% of full current beam on the detector; figure of merit is F ≈ 30.

The nonexcluded systematic error is of the order 1 × 10⁻¹³. The basic investment to this value is made by a distributed phase shift in microwave cavity, magnetic field gradients at the atoms flying into and out of H-field, and the presence of dissipated microwave power.

The latter can be found out in the limits 1 × 10⁻¹³ as a function of H-field direction and microwave power level. The cesium frequency standard uses the digital system of output signal automatic frequency control according to the cesium transient frequency. Square-pulse modulation frequency with modulation interval 4 s is used, that is achieved by the synthesizer frequency change. At the moment of synthesizer frequency changing the digital voltmeter is disabled and doesn't perform readouts to exclude transient process influence on tuning frequency.

In the control unit the error signal from atomic beam tube output is summed and averaged for the specified modulation period number. This signal is used for shaping the frequency correction signal of the hydrogen maser synthesizer. The time of error signal averaging and compensating and correspondingly the interval between corrections can be changed from 10 s to 1 hour. Figure 16 shows the results of MCs-3 standard frequency comparison with the group hydrogen keeper specifications

received by VNIIFTRI. The frequency reproducibility is 5×10^{-14} for the measurement interval up to 16 hours^[16].

At present the time intensive research on cesium atomic beam tube modification, providing minimum nonexcluded systematic error, is being in process. The main tasks of this modification are the use of ring-shaped microwave cavity, the creation of H longitudinal field, elimination of microwave power scattering, and minimizing average speed of beam atoms.

Fig.16. Table 2.

CH1-78 measuring rubidium frequency time standard specifications.		
Specifications	CH1-78a	CH1-78b
1. Output frequency values, MHz	5; 1; 0.1	5; 1; 0.1
2. Drift per 1 month	6×10^{-12}	3×10^{-11}
3. Allan variance per:		
1 s	7×10^{-12}	7×10^{-12}
10 s	3×10^{-12}	3×10^{-12}
1 day	7×10^{-13}	2×10^{-12}
4. Frequency reproducibility & relative accuracy	5×10^{-12}	5×10^{-12}
5. Mean temperature coefficient of frequency	8×10^{-13}	8×10^{-13}
6. Measurement accuracy per:		
1 s	1.4×10^{-11}	1.4×10^{-11}
10 s	1.4×10^{-12}	1.4×10^{-12}
100 s	1.4×10^{-12}	1.4×10^{-12}
7. Operating temperature range, °C	0...+50	0...+50
8. Power consumption, VA		
220 V (50 Hz)	43	43
27 V	35	35
9. Weight, Kg	17	17

REFERENCES

1. N.A. Demidov, E.M. Ezhov, V.A. Phedorov and others. *Frequency wall-shift investigation in hydrogen maser in new materials* Proc. VNIIFTRI Issledovaniya v oblasti izmereny vremeny i chastoty. Moscow, 1978, v.37(67), P.81-85
2. S.B. Pushkin, R.B. Sharikov. *Analysis of metrological characteristics of the National Time and Frequency Service reference.* Proc. VNIIFTRI. Issledovaniya v oblasti izmereny vremeny i chastoty. Moscow, 1989, P.3-8
3. B.A. Gaigerov, N.D. Zhestkova, N.B. Koshelyaevsky and others. *Basic metrological characteristics of "Chajka-Cheget" instruments complex used in the National Time and Frequency Service* Fhes. of papers of IVth all-union symp. Issledovaniya v oblasti izmereny vremeny i chastoty. VNIIFTRI, Moscow, 1990-P.4
4. S.L. Gordeev, N.A. Demidov, E.M. Ezhov. *Getter pump gas absorber for hydrogen pumping out* A.s. 918.510. USSR Bjulleten Izobreteny, 1982, N 13
5. G.A. Elkin, A.I. Bojko, N.D. Zhestkova. *Stabilization of direct magnetical field in hydrogen maser* Thes. of papers of Vth all-union confer. "Metrologiya v radioelectronice" VNIIFTRI, Moscow, 1981, P.88
6. F.L. Walls, H. Hellwig. *A new kind of passively operating hydrogen frequency standards* Proc.30th Ann. Symp. Freq. Contr., 1976, P.473-480
7. E.S. Salisky, N.A. Weakliem. *An Operating Development Modes Spacecraft Hydrogen Maser* Proc. 32th Ann. Freq. Contr. Symp., 1978, P.499-505
8. H.E. Peters. *Small, very small and extremely small hydrogen maser* Proc. 32th Ann. Freq. Contr. Symp., 1979, P.469
9. V.A. Bochkov, B.A. Gaigerov, V.P. Korolyov and others. *Hydrogen maser with smallsize cavity* Radiotekhnika i electronica, 1981, VXXVI, N 11-P.2471
10. A.A. Belyaev, N.A. Demidov, S.B. Povalyashko. *Hydrogen discriminator* A.s. N 1.336.881 USSR. Otkritiya.Izobreteniya N 33,1987
11. A.A. Belyaev, N.A. Demidov, Makarychev. *Hydrogen maser* A.s. N 1.459.568 USSR. Otkritiya. Izobreteniya, N 6,1989
12. G. Bursa, H. Brandenberger. *Passive H-maser* Proc.33rd Ann. Freq. Contr. Symp., 1979, P.563-568
13. N.A. Demidov, B.A. Sakharov. *Passive H-maser* A.s.N 1.258.212 USSR. Otkritiya. Izobreteniya. N 34 1986
14. A.S. Perlin, V.P. Egorov, N.V. Korolyova. *The results of hydrogen maser behavior research comparing to the National Time and Frequency Service reference.* Thes. of IVth all-union symp. Issledovaniya v oblasti izmereny vremeny i hastoty. VNIIFTRI. Moscow, 1990, P.13.
15. N.A. Demidov, V.A. Phedorov, V.I. Phedoseev. *Flexible storage bulb for hydrogen maser* A.s. N 1.137.947 USSR. Otkritiya. Izobreteniya, 1985, N 4

16. L.I. Polyakova, V.Yu. Runov, Yu.V. Timofeev and others. *The results of research of metrological Cesium frequency standard* Thes of papers Vth all-union conf. "Metrologiya v radioelektronike" VNIIFTRI Moscow, 1984, P.253-255
17. Yu.G. Abashev, G.A. Elkin, Yu.V. Timofeev. *The results of the cesium frequency reper MCs-3 used in the National Time and Frequency Service.* Thes. of papers IVth all-union conf. "Metrologiya v radioelektronike" VNIIFTRI, Moscow, 1984, P.253-255
18. N.D. Zhestkova, G.A. Elkin, V.T. Zemscova. *The hydrogen reper of frequency and determination of absolute frequency* Izmeritel'naja tekhnika. , N10, 1976, P.50-51.
19. N.A. Demidov, E.M. Ezhov, A.A. Uljanov and others. *A frequency wall-shift investigation in the hydrogen maser.* Izmeritel'naja tekhnika , N7, 1977, P.45-47.
20. H. Hellwig, R.F.C. Vessot, M.W. Levin and others. *Measurement of unperturbed hydrogen hyperline transition frequency* IEEE Trans. on Instrum. and Measur.
21. D. Morris Metrologia , v7, N4, 1971, P.162-166.

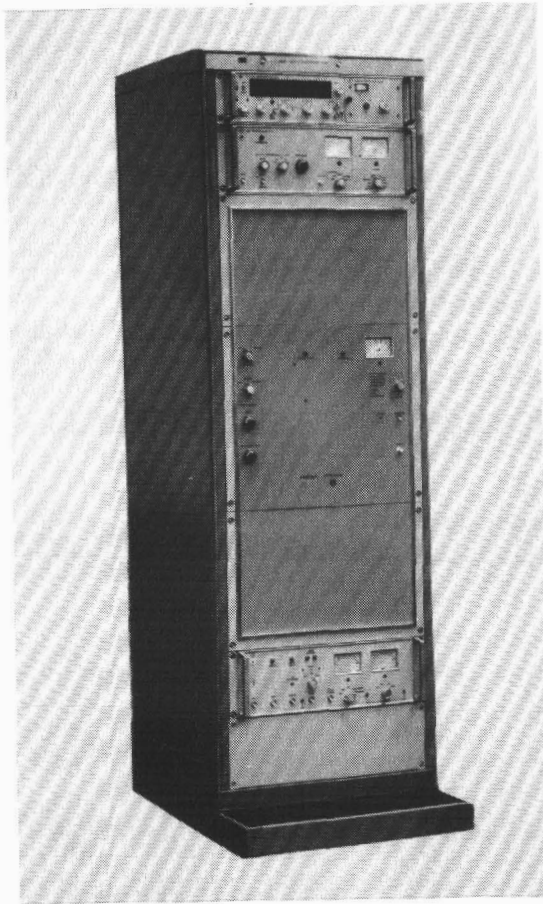

Fig.1. CH1-70 hydrogen maser.

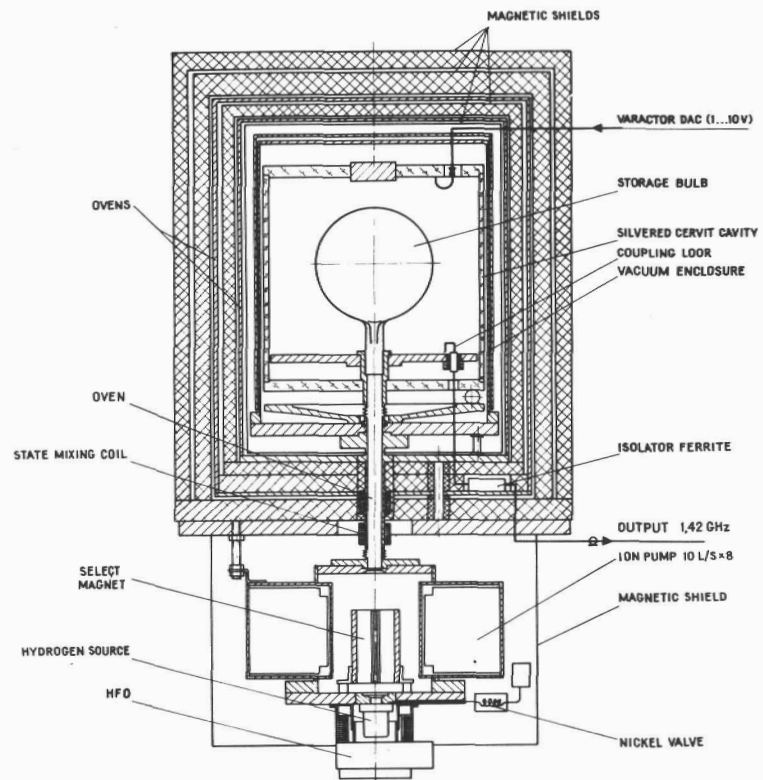

Fig.2. CH1-70 hydrogen maser schematic.

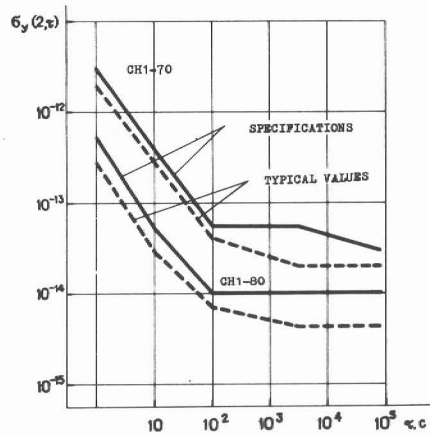
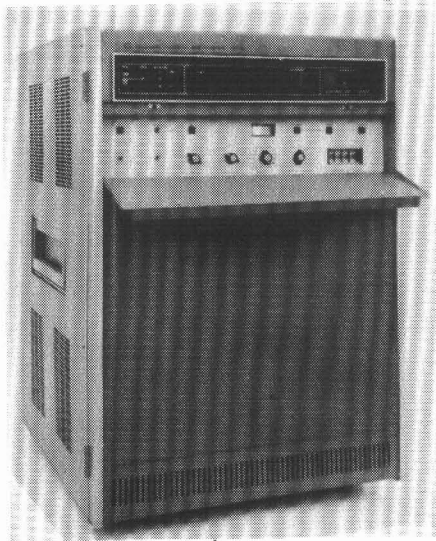

Fig.3. Frequency stability per 1, 10, 100 s, 1 h and 24 h. Additional frequency shift change: less than $1.5 \cdot 10^{-14}$ for CH1-70 and less than 10^{-14} for CH1-80. at 1 C ambient temperature



a)

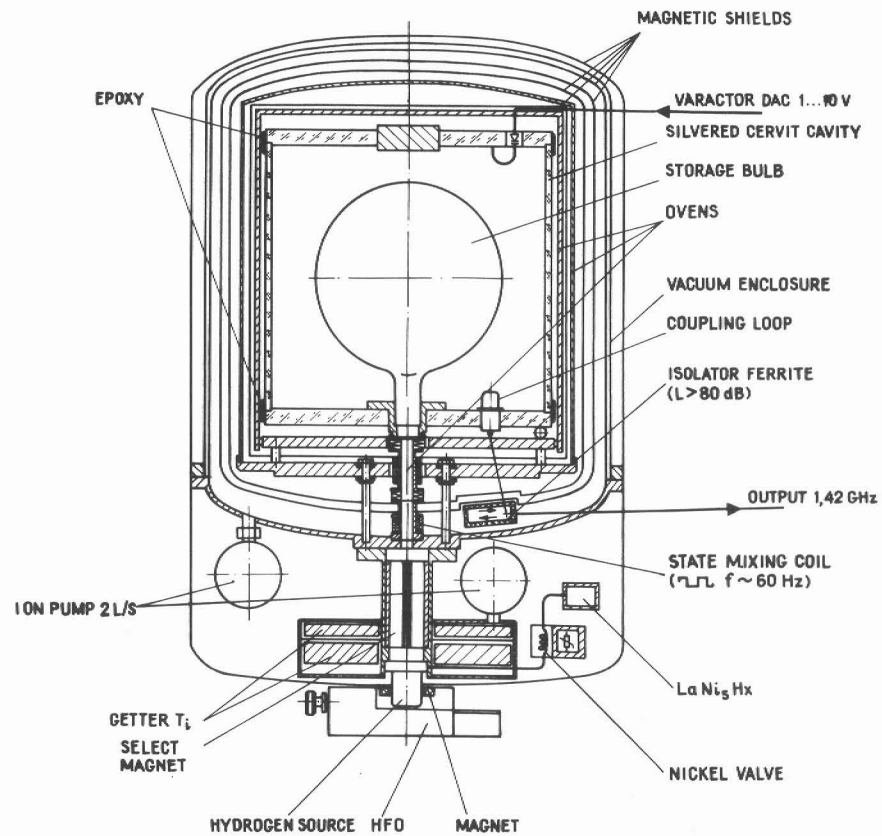

Fig.4. CH1-75 hydrogen maser:
a) photo; b) schematic design.

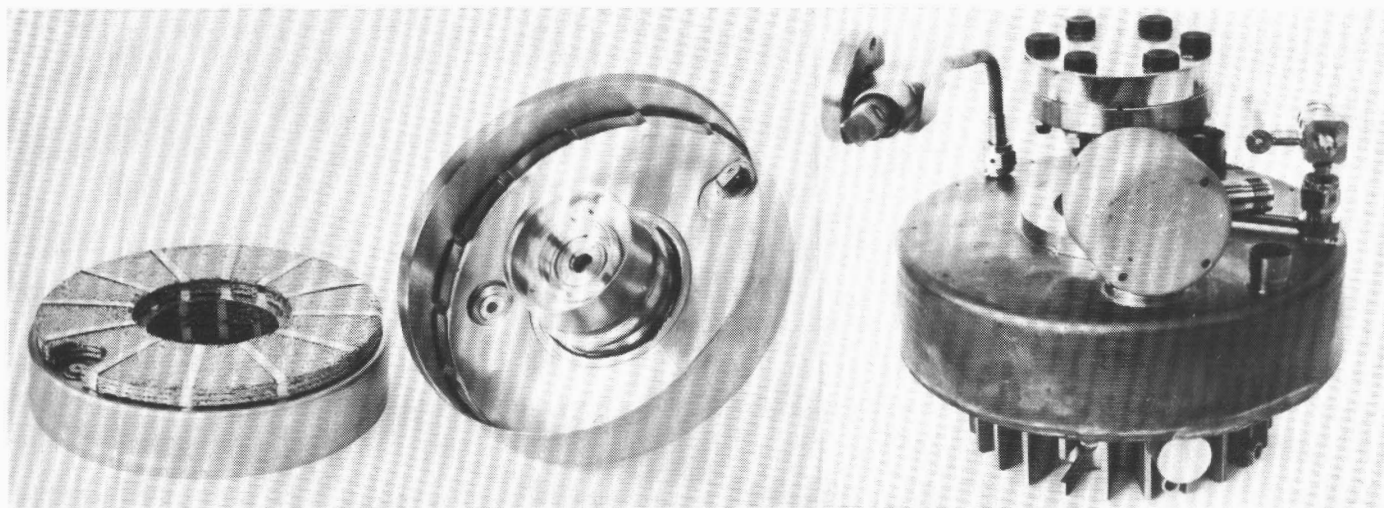

Fig.5. Getter pump of hydrogen masers CH1-75, CH1-76.

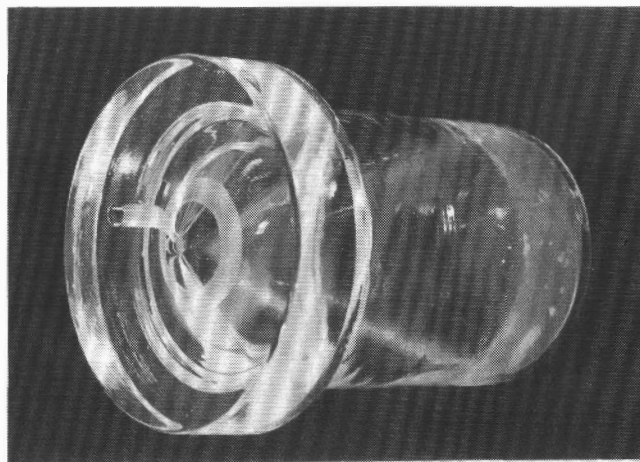

Fig.6. Quartz discharge bulb of hydrogen masers CH1-75, CH1-76.

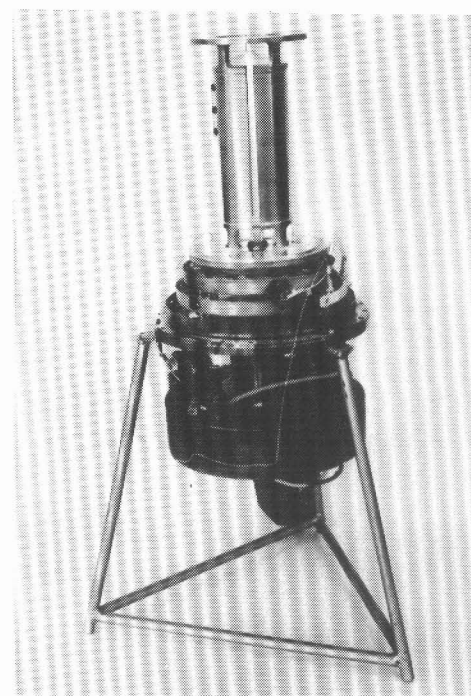
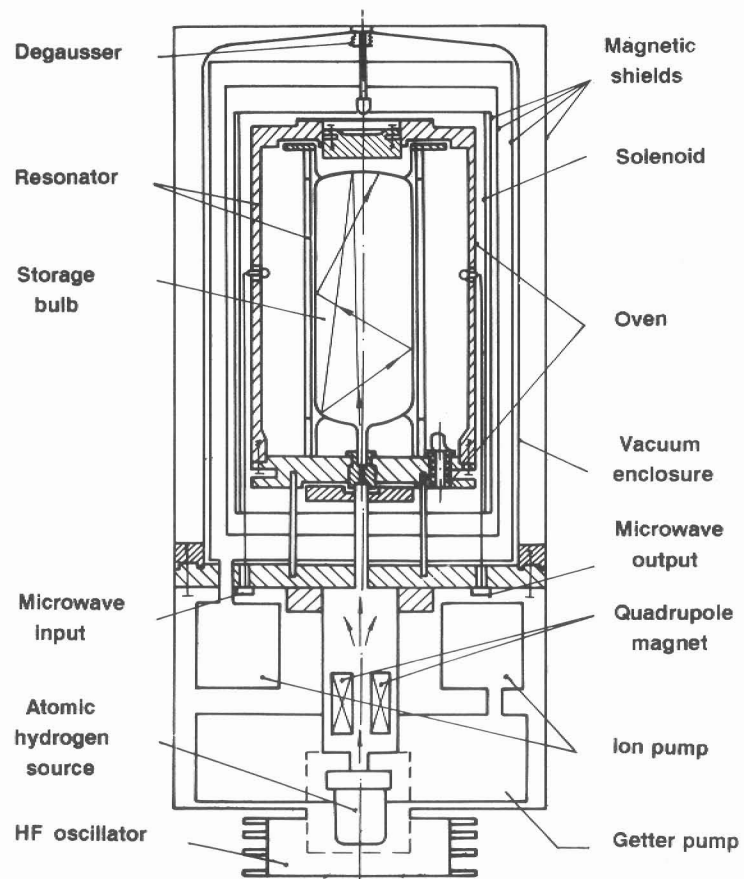

Fig.7. CH1-76 hydrogen maser:
 a) schematic design;
 b) assambling without vacuum tank, magnetic shields and
 cavity cylinder.

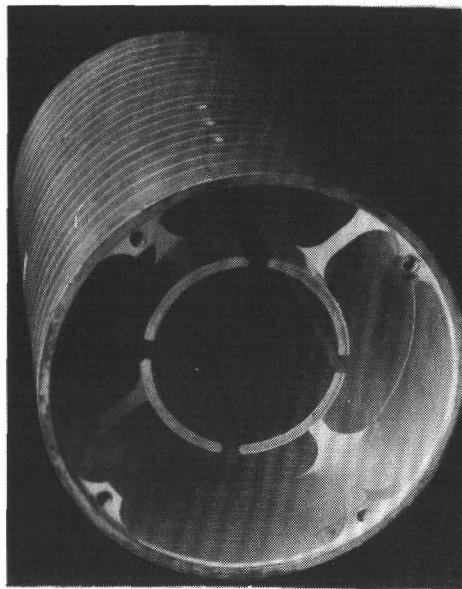

Fig.8. Photo of "magnetron" cavity.

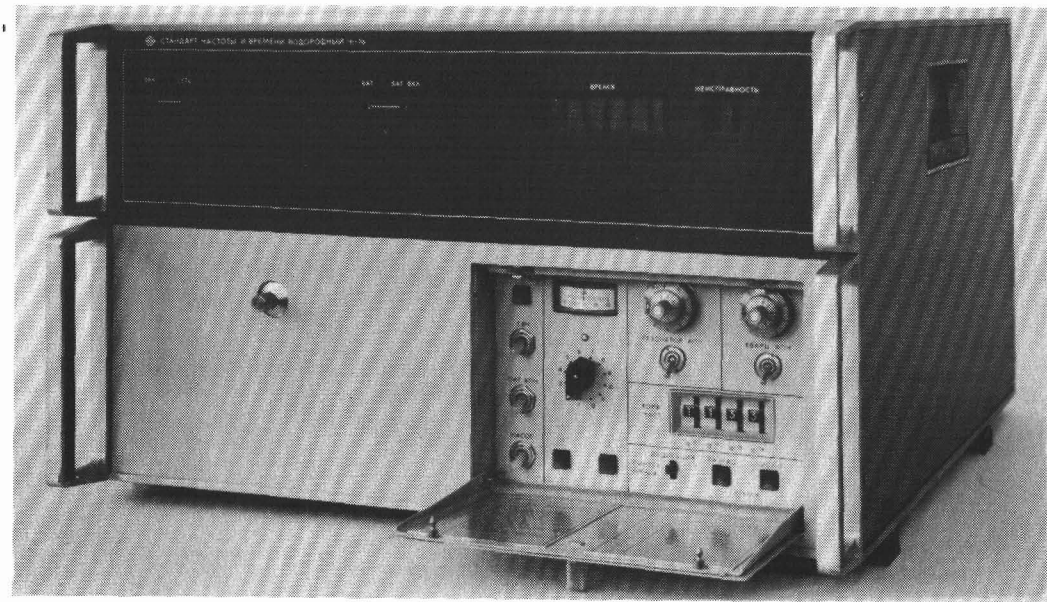
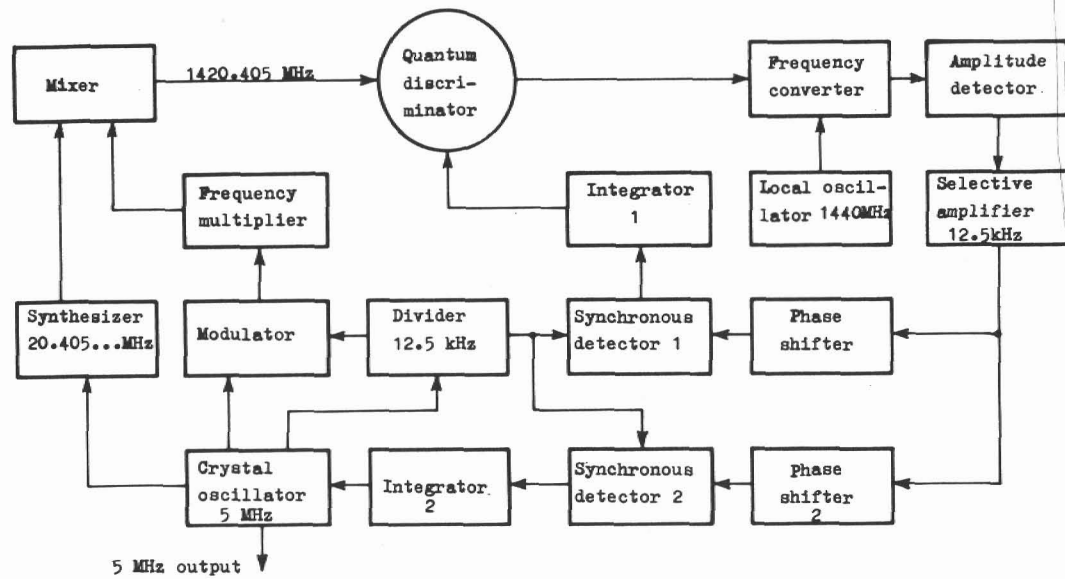
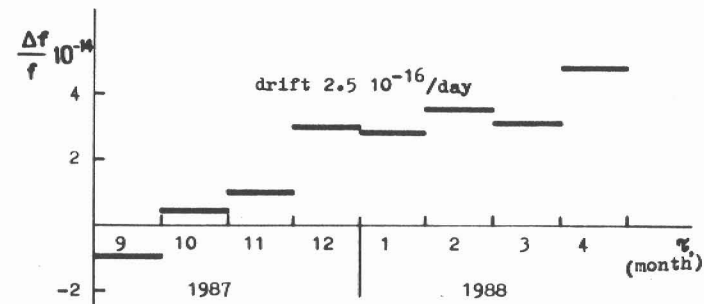
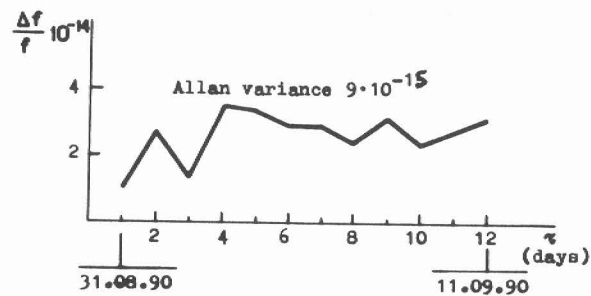

Fig.9. CH1-76 passive hydrogen maser :
a) block-diagram b) photo.



a)



b)

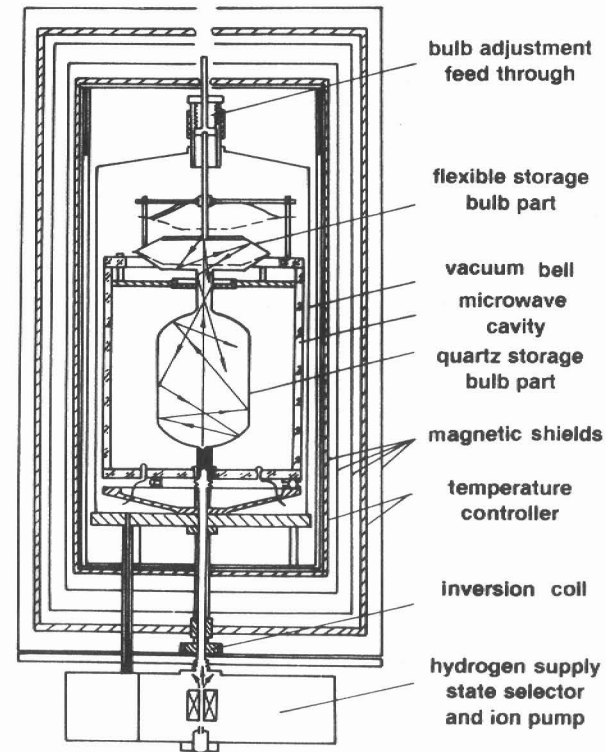
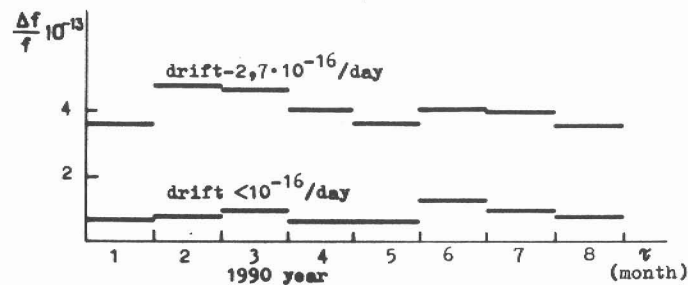

Fig.11. The hydrogen maser with flexible storage bulb.

Fig.10. The examples of output frequency behaviour of the CH1-76 commercial instruments in relation to a group of active masers: a) averaging per month; b) averaging per day; c) long-term stability analysis results of two CH1-76 (obtained in Leningrad Scientific Research Radio Technical Institute [14]).

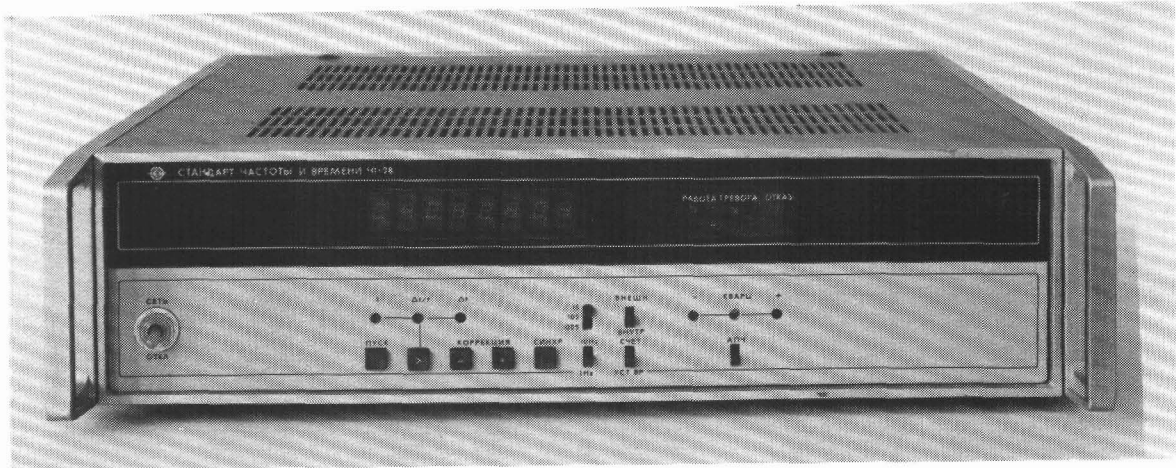

Fig.12. CH1-78 rubidium frequency standard.

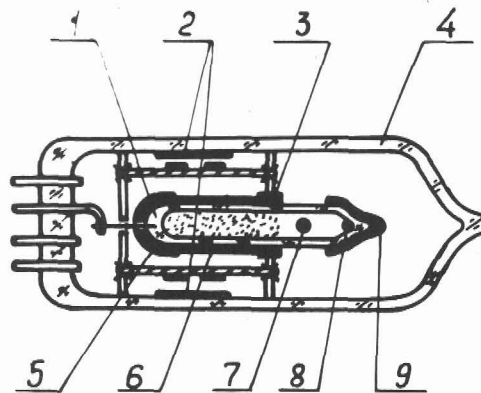

Fig.13. The gas-discharge lamp of optical pumping source for rubidium frequency standards:

- 1) gas-discharge lamp
- 2) getting reflector
- 3,5) heater contact
- 4) vacuum envelope
- 6) heater
- 7) starting electrode
- 8) Rubidium-87
- 9) high frequency electrode.

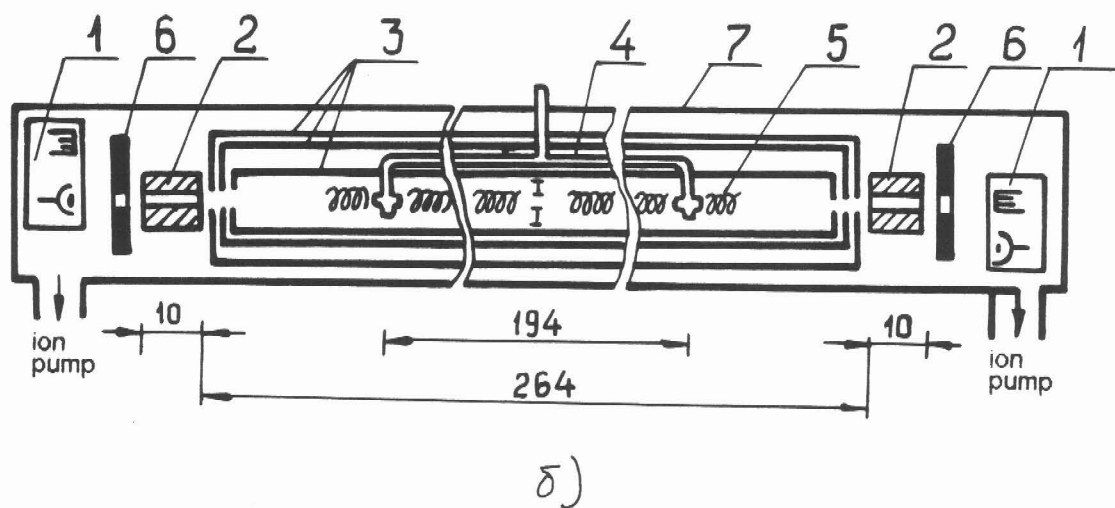
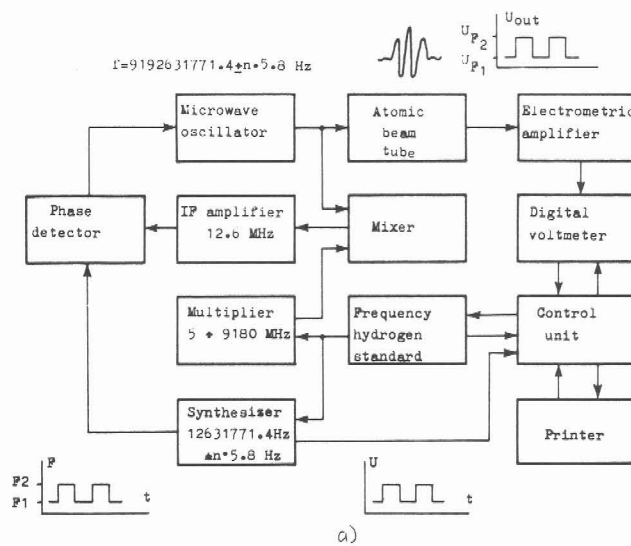

Fig.14. MCs-3 - metrology cesium frequency standard:
 a) block-diagram;
 b) the Cs atomic beam tube schematic design.
 1) beam source and detector 2) state selecting magnets 3) magnetic shields 4) microwave cavity
 5) LF-coils 6) graphite 7) vacuum envelope

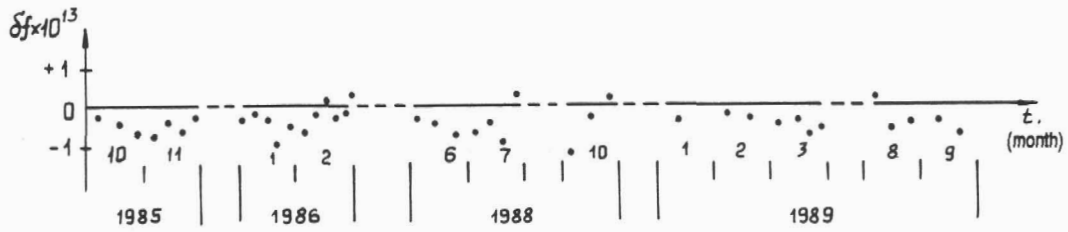

Fig.15. Relative frequency difference between MCs-3 and ensemble hydrogen clocks of the National Time and Frequency Service.

Table 2.

Table 1.

Coating material	Wall shift, Hz at 50°C D=15.7 mm	Bulb number	f=1420405751 Hz	Data reference, year
F-4DU	-0,0242 ±0,0014	10	...,7682 ±0,0014	[18], 1976
F-4D	-0,034 ±0,004	6	...,77 ±0,005	[19], 1977
TFE-42	-0,0337 ±0,001	11	...,768 ±0,002	[20], 1970
FEP-120	-0,022 ±0,001	6	...,77 ±0,003	[21], 1971
F-10		flexi- ble bulb	...,7709 ±0,0005	1988

The received frequency value $f_o = 1420405751.7709 + 0.0005$ Hz is

QUESTIONS AND ANSWERS

Albert Kirk, Jet Propulsion Laboratory: The Allan variance data that you showed—was that taken while the maser was autotuning?

Dr. Demidov: Yes