

A HIGHLY STABLE CRYSTAL OSCILLATOR APPLIED TO GEODETIC VLBI EXPERIMENT

Hitoshi KIUCHI and Jun AMAGAI

Kashima Space Research Center, Communications Research Laboratory
893-1 Hirai, Kashima, Ibaraki 314 Japan

ABSTRACT

Instead of a hydrogen maser, a carefully selected Crystal oscillator which is phase locked to a Cesium (Cs) frequency standard for time range of more than 100 seconds is adopted to the time and frequency standard of a geodetic VLBI experiment. The domestic VLBI experiment with 55km baseline using the Crystal oscillator at one end was made in Japan and the obtained error of the baseline vector components were 4cm, and that of the baseline length was 3cm. This system may be operated after only 2 hours warm up. These results coincides with those of conventional geodetic Laser ranging and VLBI using a hydrogen maser within the formal error. A VLBI experiment with over 1000km baselines were carried out successfully from October 1988, and over 11000km baseline between Japan and Antarctica was carried out successfully in January 1990.

1. INTRODUCTION

Very long Baseline Interferometry (VLBI) is one of the most accurate modern positioning techniques. Although it was initially developed by astronomers as a tool to improve the angular resolution of radio telescopes, it was realized that it would also be an ideal geodetic instrument. In usual VLBI experiments made for geodetic purpose, each antenna receives signals from a radio source for a hundred seconds or more in one observation. This observation is repeated changing between dozen or more radio sources during a nominal 24-hour session. A single experiment therefore consists of a hundred or more observations. The frequency standard of VLBI must be stable over a long time range (more than 100sec) as well as a short range (less than 100sec). Short time range stability is essential for maintaining the coherence and long time stability is necessary for regulating the time of observations. The hydrogen maser oscillator satisfies these requirements and this is a reason for its use for VLBI. However, recent technology has improve the stability of Crystal oscillator (AT-cut resonator of the BVA style). The possibility of Crystal oscillator as a frequency standard of VLBI will now be discussed. A hydrogen maser frequency standard with stability better than 10^{-14} has been playing an important role in the VLBI experiments. Maintaining the coherence of the receiving signal of each station is one of the most important factors in VLBI data acquisition. While the stability of the atmosphere which causes phase scintillation, is about 10^{-13} as measured by VLBI. The atmospheric scintillation degrades the coherence of VLBI data, which is independent of the phase fluctuation of hydrogen maser. Research work in the Crystal oscillators

has made remarkable progress in recent years, and the stability of the selected Crystal oscillators reaches $\sigma_y(\tau < 100\text{sec}) = 3 \times 10^{-13}$, a value comparable to the stability of the atmosphere. Therefore the potential for obtaining a good fringe by using the Crystal oscillator instead of the hydrogen maser exists. The main purpose of the new frequency reference system development was to construct a highly transportable time and frequency standard for VLBI, and in our case we adopted a Crystal oscillator for VLBI frequency reference. The Crystal oscillator has advantages for space technology application (Space VLBI etc.), and transportable VLBI because it satisfies the requirements of small size, light weight, and astatic structure.

A new frequency system which constructed a Crystal oscillator whose phase is locked to that of a Cesium frequency standard (Crystal-Cesium system) has been developed for time ranges of over 100 seconds, as the stability of Cesium frequency standard is better than that of a Crystal oscillator for long term ranges. First of all, zero and short baseline interferometer experiments were carried out to assess the performance of the Crystal-Cesium system and to find the optimum data analysis method for using Crystal-Cesium system. Secondly, the 55km baseline (a reference baseline in Japan, which has been measured 5 times by VLBI and other methods) VLBI experiment was made in order to provide a comparison with conventional results and to determine optimum integration time for this system. As a result of these experiments, the baseline vector was obtained with an error of 4.3cm on each component, and 3.4cm on its length.

2. Potential of the Crystal oscillator as the VLBI frequency standard

The stability of frequency standard in a short time period is an important factor in maintaining the coherence of received signals in VLBI experiments. However VLBI observation from the ground always suffer from the atmospheric scintillation effect, resulting in a loss of coherence. Therefore the stability of the atmosphere determine the limit of requirement for that of frequency standard in a short time range. The stability of atmosphere was measured to about 1×10^{-13} at 100sec by domestic VLBI (Fig.1), this result being almost same as those of Rogers and our measurements (Table 1). The stability of hydrogen maser is 1×10^{-14} at 100 sec and it is stable enough compared with the atmosphere, while recent technology progress has provided a stability of 3×10^{-13} for Crystal oscillators, which is almost the same as the atmosphere's stability. A Crystal oscillator is strongly proposed as a frequency standard for VLBI in a short time range.

The requirements for the VLBI frequency standard are as follows;

- (1) To keep the signal coherence during integration time.
- (2) Phase variance of the clock instability should be better than accuracy of the measurement.

The coherence loss L_c due to the instability of frequency standard in 100sec integration time is estimated by Eq.1.

$$L_c = \omega_0^2 (\alpha p / 6 + \alpha l / 12 * T + \sigma_y^2 / 57 * T^2) \dots \dots \dots (1)$$

where L_c : loss of coherence
 ω_0 : angular frequency of local oscillator
 (8080MHz in X band) [rad/sec]
 α_p : Allan variance of white phase noise at 1 sec
 $(1 \times 10^{-13})^2$: hydrogen maser at Kashima
 α_f : Allan variance of white frequency noise at 1 sec
 $(7 \times 10^{-14})^2$: hydrogen maser at Kashima
 σ_y^2 : Constant Allan variance of flicker frequency noise
 $(5.5 \times 10^{-15})^2$: hydrogen maser at Kashima
 $(3 \times 10^{-13})^2$: selected Crystal
 T: Integration time [sec]

The stability of the hydrogen maser at Kashima is shown in Fig.2. According to Eq.1, the calculated losses for hydrogen maser and Crystal oscillator at an integration time of 100sec are 1.23×10^{-4} and 0.041 respectively, and compared with the loss due to 1 bit sampling (Loss=0.36) at data acquisition they are small enough to be ignored. Long term stability of the frequency standard is necessary for regulating the results of each observation when analyzing them. Though the long term stability of the Crystal oscillator is not acceptable for VLBI, the high performance Cesium frequency standard has a superior stability in a long term ($\sigma_y(\tau > 100) \leq 3 \times 10^{-13}$). But if only Cesium is used in VLBI experiments, it is impossible to keep the coherence of the X band signal, as the stability of Cesium is worse than $\sigma_y = 10^{-12}$ in short term during signal integration. Hence a frequency standard, which has the stability of the Crystal in a short time range and that of Cesium in a long time range, is needed to satisfy the requirements of VLBI and can be realized by using a Crystal oscillator with its phase locked to the Cesium frequency standard in a long time range.

The required stability of this equipment is the shaded area in Fig. 3. Stability measurements with Zero Baseline Interferometry and the short baseline VLBI experiment were made.

3. The stability measurement with Zero Baseline Interferometry

Stability was measured with Zero Baseline Interferometry (ZBI) (Fig.4). This method used the K-3 VLBI system which was developed at CRL. System noise of this method is very low and this measurement is realistic method for VLBI experiments, because the performance of the oscillator is measured in the same configuration. In VLBI, the geodetic reference point is the intersection point of axes of Azimuth(Az) and that of Elevation(EI), and is a stationary point. In ZBI method, both receiving systems are mounted on a same antenna. In this case, the baseline length is zero, because the geodetic reference point is common for both systems.

The common noise generated by Noise Diode is injected to both X band feeder systems. The reference signal is supplied to one system by a hydrogen maser and to the other by the test

frequency system(DUT : Device Under test). A cross correlation was made between the two systems in real time by using the K-3 VLBI correlation processor. Then the resulting stability was equivalent to both references. In this case, the DUT's are a Cesium, a Crystal and the Crystal-Cesium system. This method is a modified DMTD (Double Mixer Time Difference) method. The results are shown in Fig.5, which shows the detected fringe phase in the X band. It is possible to find out the long term characteristics in stability of the frequency standard. The result of using Crystal oscillator (Fig.5a) shows random walk over the long term caused by the external temperature change. When using Cesium frequency standard (Fig. 5b), the fringe phase is stable in the long term. And in case of using a Crystal-Cesium system frequency standard (Fig.5c), the fringe phase is as stable as when using only a Cesium frequency standard. Fig.6 shows the observed delay in X band. This detected fringe phase is the respective instrumental delay of two systems. It is possible to find out the capability for keeping coherence. When using Crystal oscillator (Fig.6a), it is possible to get a good fringe, and the determined delay is stable. When a Cesium frequency standard is used (Fig.6b), the determined delay changed as much as 100 nsec, and thus it is impossible to keep the coherence in the X band. This means the Cesium frequency standard is not suitable for the frequency standard of VLBI in the X band. The results from the Crystal-Cesium system (Fig.6c) have the same characteristics as those from when only the Crystal oscillator was used.

Fig.7 shows that the coherence depends on integration time, and it is calculated directly from the correlated data. It is possible to tell coherence from this Figure.

Fig.8 shows the stability of the Crystal-Cesium system, which is measured by the detected fringe.

These results show that the Crystal oscillator has a good short term stability but it is inferior to the Cesium frequency standard in the long term, while a Cesium standard has a excellent long term stability but it is unusable for X band VLBI experiments. The Crystal-Cesium system is very close to meeting requirements.

4. Estimation of the optimum integration time for the Crystal-Cesium system

The SNR of VLBI is calculated by Eq.2.

$$SNR = [\pi * S_c / 8k] * [D_1 * D_2 * \sqrt{(\eta_1 * \eta_2)} / \sqrt{(T_{s1} * T_{s2})}] * \sqrt{2BT} * \rho \dots\dots(2)$$

where S_c : correlated flux of source k : Boltzman constant
 D : diameter of the antenna η : antenna efficiency
 T_s : system temperature B : band width
 T : integration time

$$\rho = (2/\pi) * 0.6 * \sqrt{3/4}$$

: : :..... Fringe stopping loss
 : :..... Scintillation loss
 :..... 1 bit sampling loss

The coherence loss is expressed by Eq.1. There is an optimum integration time which gives the maximum SNR*coherence, and an estimate of this suitable integration time is shown in Fig.9. Fig.9 (a) shows the estimated SNR*coherence were a fixed Cesium stability ($\sigma_y(1)=3 \times 10^{-12}$) and variable Crystal stability are used. Fig. 9(b) shows the opposite situation (fixed Crystal stability and variable Cesium stability), where fixed Crystal stability is $\sigma_y(1)=4 \times 10^{-13}$. The optimum integration time depends on the stability of the Crystal oscillator and that of the Cesium frequency standard. When using high performance commercial Cesium, the SNR*coherence has a maximum value at about 120 sec integration time. As in this case the clock error is less than 0.05 nsec, it can be said that the optimum integration time is 120sec for this system. It is possible to use the data with SNR better than 7 for VLBI data analysis. In other words, the Crystal-Cesium system, which can get SNR of better than 7 in 120 sec integration time can be used with the VLBI antenna pair.

5. The 55km baseline experiment

An experiment with the 55km baseline, which is regarded as a reference VLBI baseline in Japan, was made immediately after JEG-5(fifth Geodetic VLBI experiment between Tsukuba GSI : Geographical Survey Institute, and Kashima CRL using hydrogen masers at both stations) and the schedule of JEG-5 was repeated, in order to avoid problems arising from the change of the propagation media error. A Crystal, a Cesium frequency standard and a PLL circuit were transported from Kashima to Tsukuba 2 hours before the start of the experiment. The 26m Az-El type Radio telescope at CRL Kashima and the 5m Az-El type Radio telescope at GSI Tsukuba were used. Both Radio telescopes are equipped with the K-3 VLBI system. A hydrogen maser frequency standard is used as the reference signal at Kashima station and the Crystal-Cesium system is used at Tsukuba station. Other parts of the system were the same as the JEG-5 experiment. The experiment was done for 24 hours, and the cross correlation was made in Kashima. The results are shown in Table.2. In order to compare the accuracy dependence for the integration time, the results for the following three cases were analyzed.

- case I : Same integration time as JEG-5
(80 to 300sec integration time which depends on the source flux)
- case II : Integration time fixed for 120sec.
- case III : Integration time fixed for 60sec.

The most accurate result is obtained with a 120sec integration time (case II). In case I, some correlated peak (fringe phase) on delay rate is detectable, and shows that the rate changed within the integration time. In case III, it is impossible to get SNR better than 7 at the weak radio sources. The difference between the result with the hydrogen maser(JEG-5) and that of the Crystal-Cesium system (case II) is less than 4.3cm in baseline vector and 3.4cm in baseline length.

6. Application of the Crystal-Cesium system to the 1000km+ baseline VLBI experiments

The over 1000km baseline VLBI experiments were made from October 1988. The first experiment between Kashima and Wakkanai, the northernmost part of Japan. In this experiment, the highly transportable VLBI station which consists of a 3m antenna, the antenna control unit, the K-4 VLBI system and the Crystal-Cesium system, was operated in Wakkanai. This system is the smallest VLBI data acquisition system in the world. Generally the measured accuracy of VLBI worsens as antenna size decreased, but this system has overcome the problem through the wide bandwidth receiving. The receiving bandwidth (273MHz effective band width) is twice as wide as the normal X band bandwidth (128MHz) in CDP experiment. The K-4 VLBI system is a data acquisition system which was developed at CRL for application in transportable VLBI station. The direction of the baseline vector was approximately North-South. Good fringes and the good results were obtained from this system. The baseline vector was obtained with errors of 5.1cm in the X, 3.8cm in the Y, 6.2cm in the Z components, and the an error of 1.5cm in its length on VLBI coordinate. The errors of 1.4cm in the North-South component, 1.0cm in the East-West component (horizontal components) and 8.7cm in vertical component were obtained. The results show that sensitivity in horizontal components is good, making analysis of plate motion possible, and also shows the effectiveness of the Crystal-Cesium system for VLBI frequency standard even for VLBI experiments with baselines over 1000km.

In January 1990, the Antarctica VLBI was carried out. The equipments were same as the Wakkanai VLBI experiment eliminate the antenna system. The Crystal-Cesium system was operated in Antarctica, and we can get the good geodetic results. The baseline vector was obtained with errors within 20cm.

7.DISCUSSION & CONCLUSION

Instead of a hydrogen maser, a carefully selected Crystal oscillator which is phase locked to a Cesium frequency standard for time ranges 100 seconds is adopted to the time and frequency standard of a geodetic VLBI experiment. The stability of the atmosphere is about 10^{-13} . The atmospheric scintillation degrades the coherence of the VLBI data, which is independent of the phase fluctuation of hydrogen maser. It is impossible to avoid to this effect even if a hydrogen maser is used. Research work in the Crystal oscillators has made remarkable progress in recent years, and the stability of selected Crystal oscillators reaches 3×10^{-13} , a value comparable to the stability of the atmosphere. Therefore the potential for obtaining good fringes by using the Crystal oscillator instead of the hydrogen maser exists. But the Crystal oscillator is inferior to a Cesium frequency standard in long term stability. A frequency standard, which has the stability of the Crystal in a short time range and that of Cesium in a long time range, is needed to satisfy the requirements of VLBI and can be realized by using a Crystal oscillator with its phase locked to the Cesium frequency standard in a long time range. The main purpose of the new frequency reference system development was to contract a highly transportable time and frequency standard for VLBI. The

Crystal oscillator has advantages for space technology application (Space VLBI etc.), and transportable VLBI because it satisfies the requirement of small size, light weight, and aseismic structure.

This system can be used for VLBI frequency standard, and it has advantages for use with a transportable VLBI system, but its accuracy is worse than that of a hydrogen maser system. Although ambient temperature control was not considered, external temperature control is desirable to keep the stability of the Crystal in Flicker in using the Crystal oscillator, as it has a strong dependency on temperature. We expect to develop the Crystal oscillator which has a stability better than 1×10^{-13} . The coherence loss caused by this stability is 0.0045, which is small enough for keeping coherence.

The domestic VLBI experiment with 55km baseline using the Crystal oscillator at one end was made in Japan and the obtained error of the baseline vector components were 4cm, and that of the baseline length was 3cm. This system may be operated after only 2 hours warm up. These results coincide with those of conventional geodetic Laser ranging and VLBI using a hydrogen maser within the formal error. A VLBI experiment using this system with over 1000km baseline was carried out successfully in Oct. 1988 and over 11000km baseline between Japan and Antarctica was carried out successfully in Jan. 1990.

ACKNOWLEDGEMENT

The Crystal oscillator was specially selected by the OSCILLOQUARTZ company in Switzerland for our experiment. We would like to express our thanks to Dr. Schlueter, the director of OSCILLOQUARTZ. We are indebted to the staff members of Geographical Survey Institute in the domestic experiment.

REFERENCE

- [1] Rogers, A.E.E.; "The sensitivity of a Very long baseline interferometer", Radio Interferometry Techniques for Geodesy, NASA Conference Publication 2115, 1980.
- [2] Kiuchi, H., J. Amagai, S. Hama, T. Yoshino, N. Kawaguchi, and N. Kurihara; "Instrumental Delay Calibration by Zero Baseline Interferometry for International VLBI Time Comparison", J. Rad. Res. Labs., 34, 143, 115-139, Nov. 1987.
- [3] Amagai, J., H. Kiuchi, and N. Kawaguchi; "Short baseline experiment using the highly transportable VLBI station", IEEE-IM Special issue, Apr. 1989.
- [4] Rogers, A. E. E. ; "Coherence Limits for Very-Long-Baseline Interferometry", IEEE trans., IM-30, 4, 283-286, Dec. 1981.
- [5] Kawaguchi, N. ; "Coherence loss and delay observation error in Very-Long-Baseline Interferometry", J. Rad. Res. Labs., 30, 129, 59-87, Mar. 1983.
- [6] Morikawa, T., Y. Ohta, and H. Kiuchi; "Development of hydrogen masers for K-3 VLBI system". PTTI, 1984.

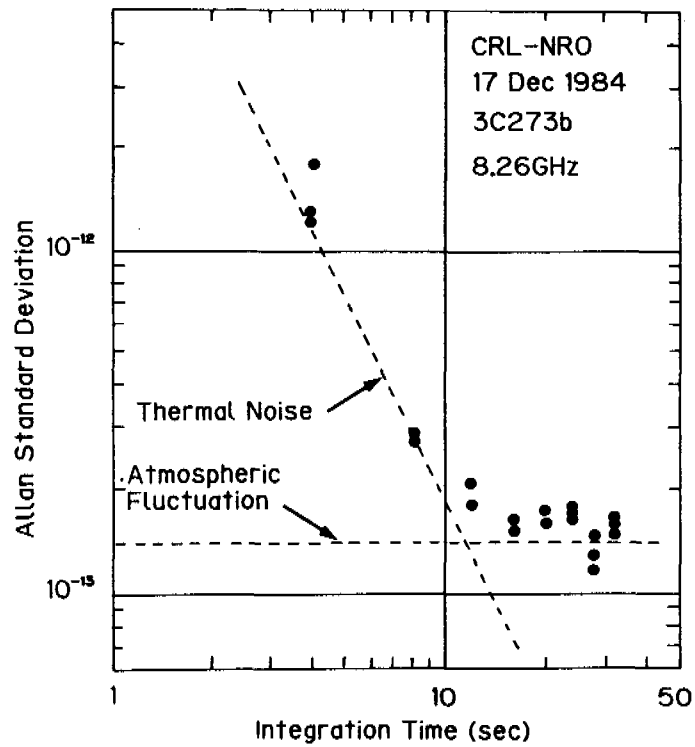

Fig. 1 Atmospheric fluctuation in Allan standard deviation

This is the result of the domestic VLBI between CRL-NRO (Nobeyama Radio Observatory) in Dec. 1984. X-axis shows the integration time and Y-axis shows the stability in Allan variance.

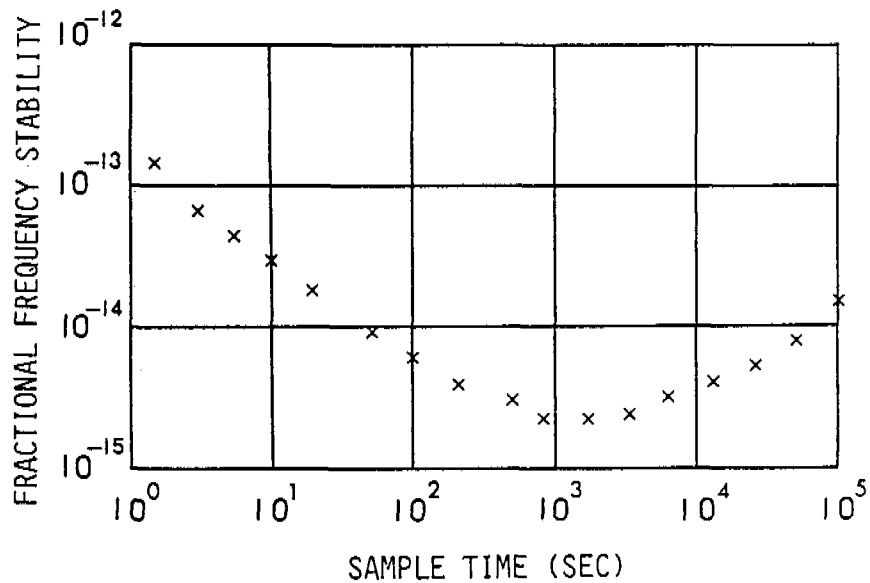

Fig. 2 Stability of the hydrogen maser in Kashima station

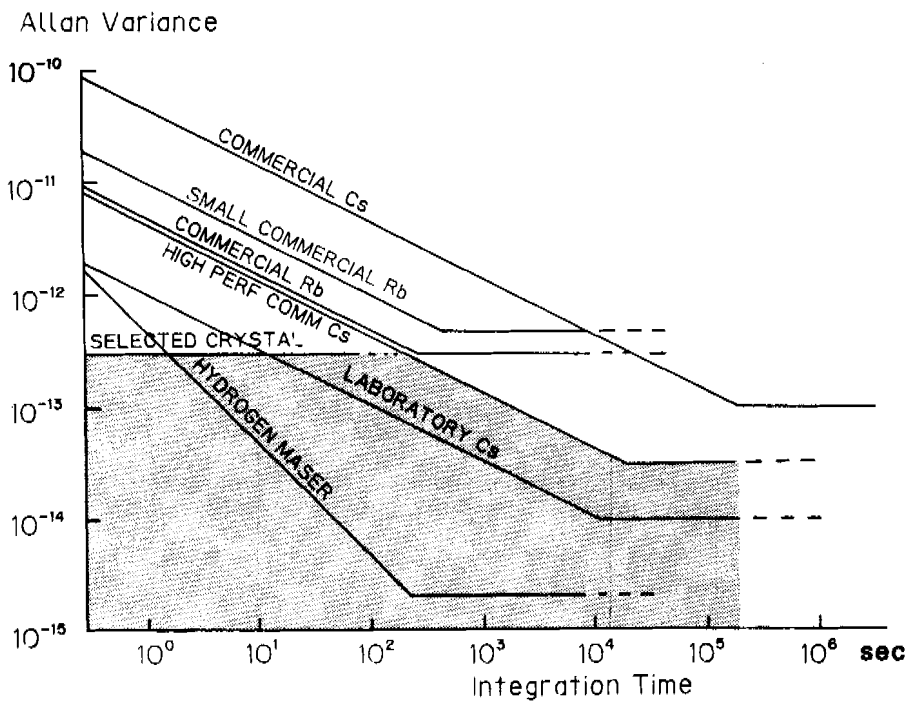

Fig. 3 Required stability

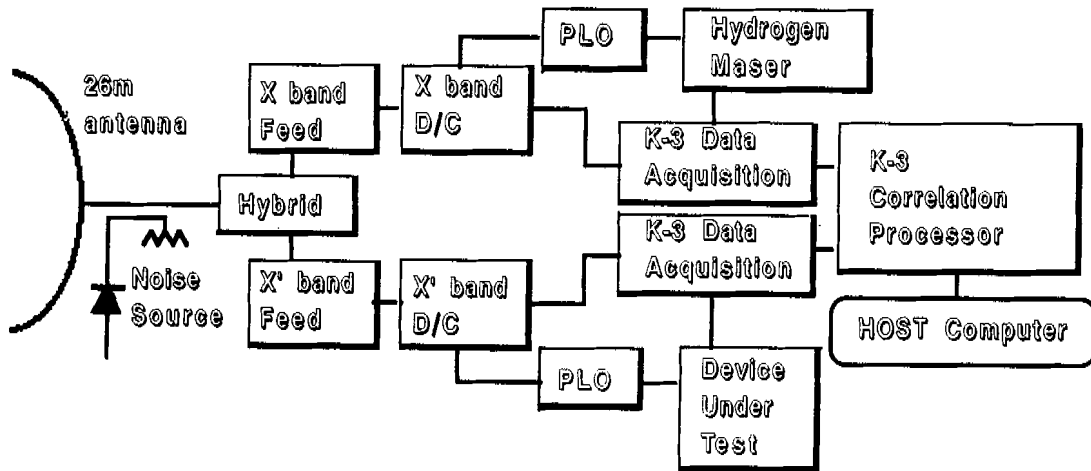

Fig. 4 Block diagram of the stability measurement system

QUESTIONS AND ANSWERS

Professor S. Leschiutta, University of Turin: First, what was the type or model of crystal oscillator used, and second, what order of servo loop and, if a simple loop, what was the time constant?

Mr. Hamma: The oscillator was a BVA oscillator from Oscilloquartz. (Editors note: The following answer was not available at the meeting, but was obtained later by private communication.) The loop was a quadratic one (second order) with $\tau_1 \simeq 100$ seconds and $\tau_2 \simeq 250$ seconds.

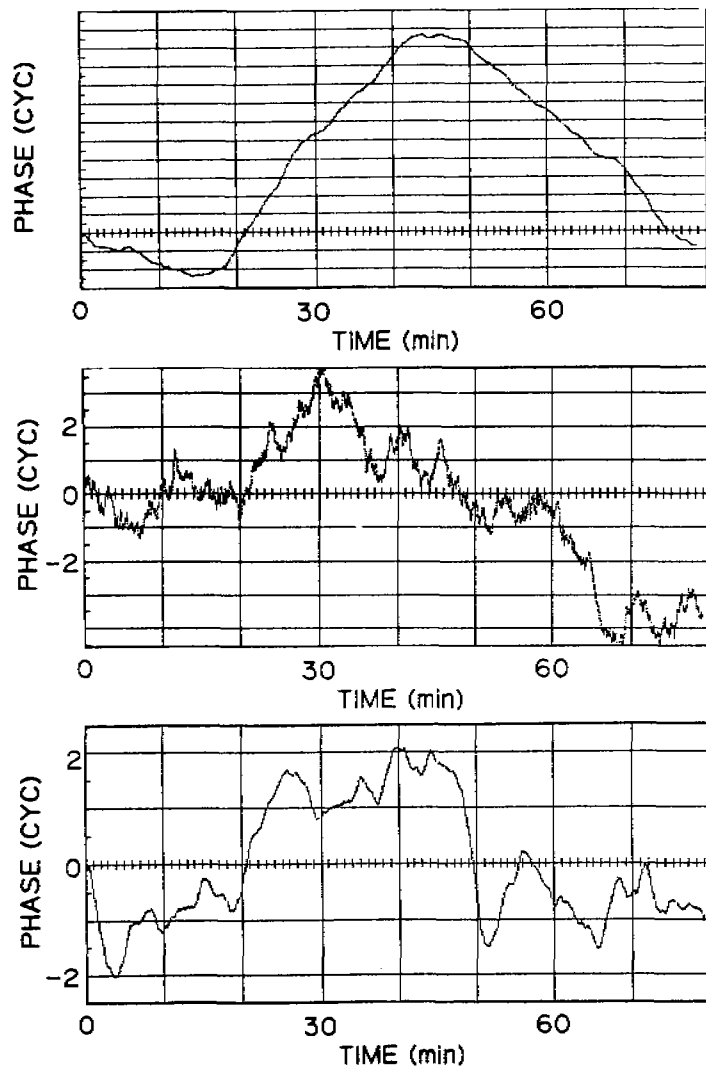

Fig. 5 Variation of the correlated phase
(in regular order)

- (a) The result of using a Crystal oscillator only
- (b) The result of using a Cesium standard only
- (c) The result of using a Crystal-Cesium system

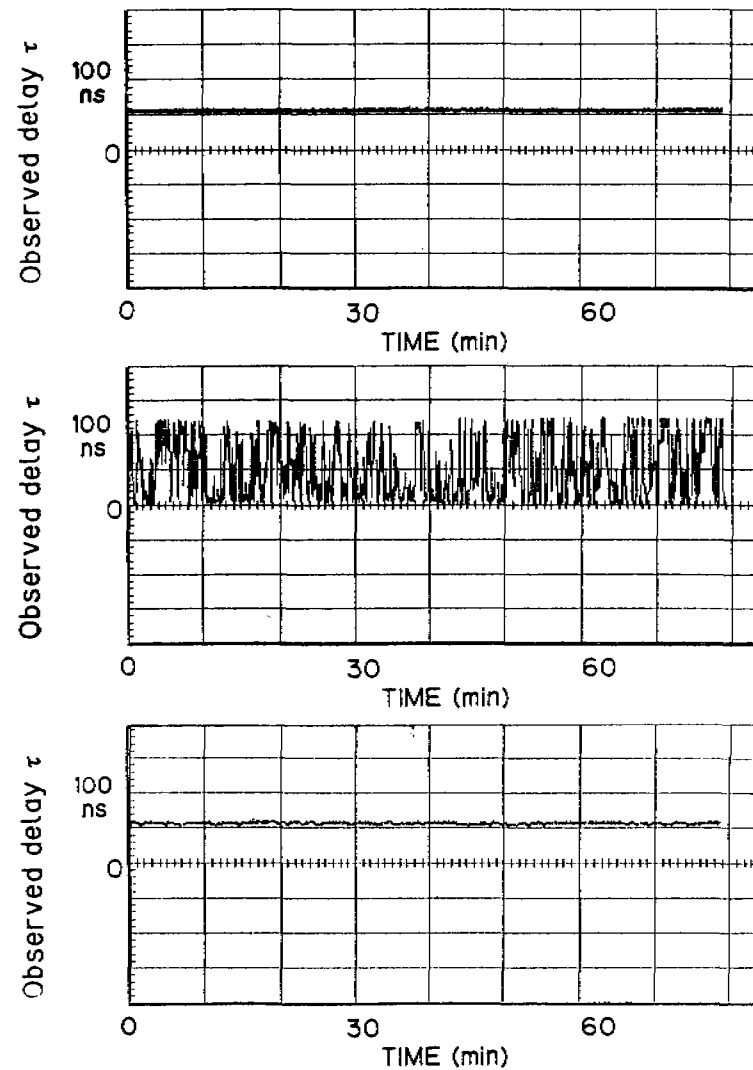

Fig. 6 Variation of the determined delay
(in regular order)

- (a) The result of using a Crystal oscillator only
- (b) The result of using a Cesium standard only
- (c) The result of using a Crystal-Cesium system

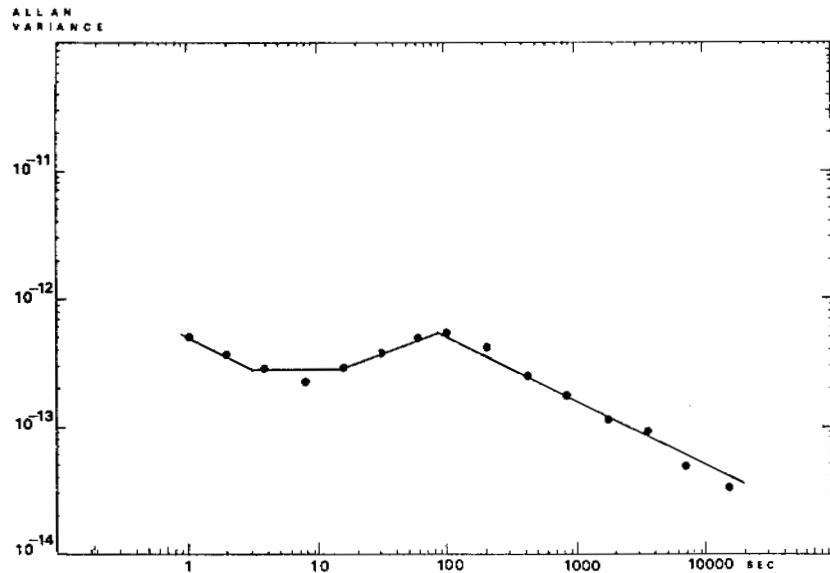
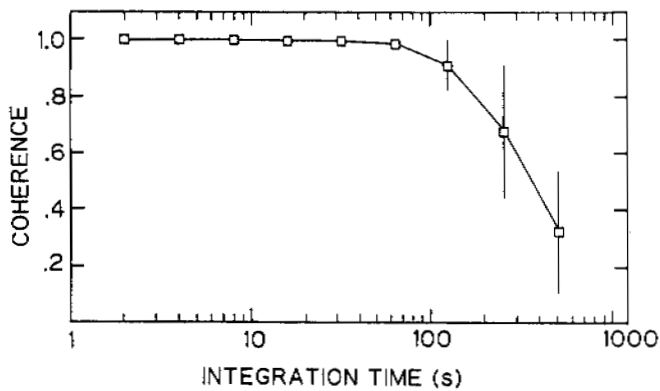
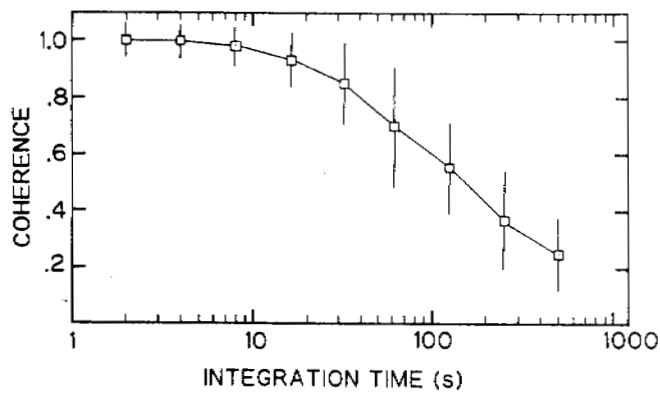
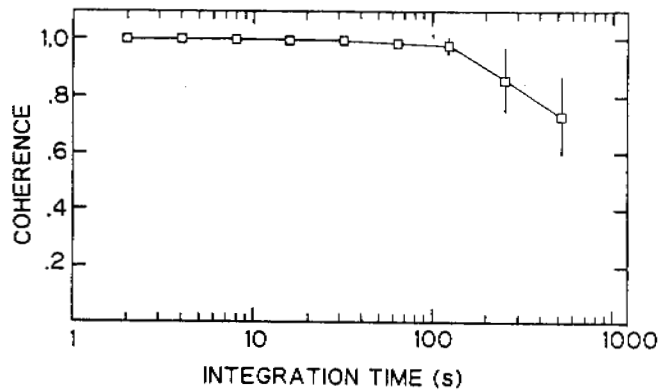

Fig. 8 Stability of the Crystal-Cesium system

Fig. 7 Coherence

(in regular order)

(a) The result of using a Crystal oscillator only

(b) The result of using a Cesium standard only

(c) The result of using a Crystal-Cesium system

Fixed stability of the Cesium Frequency Standard [$\sigma_y(\tau=1) = 3 \times 10^{-12}$]

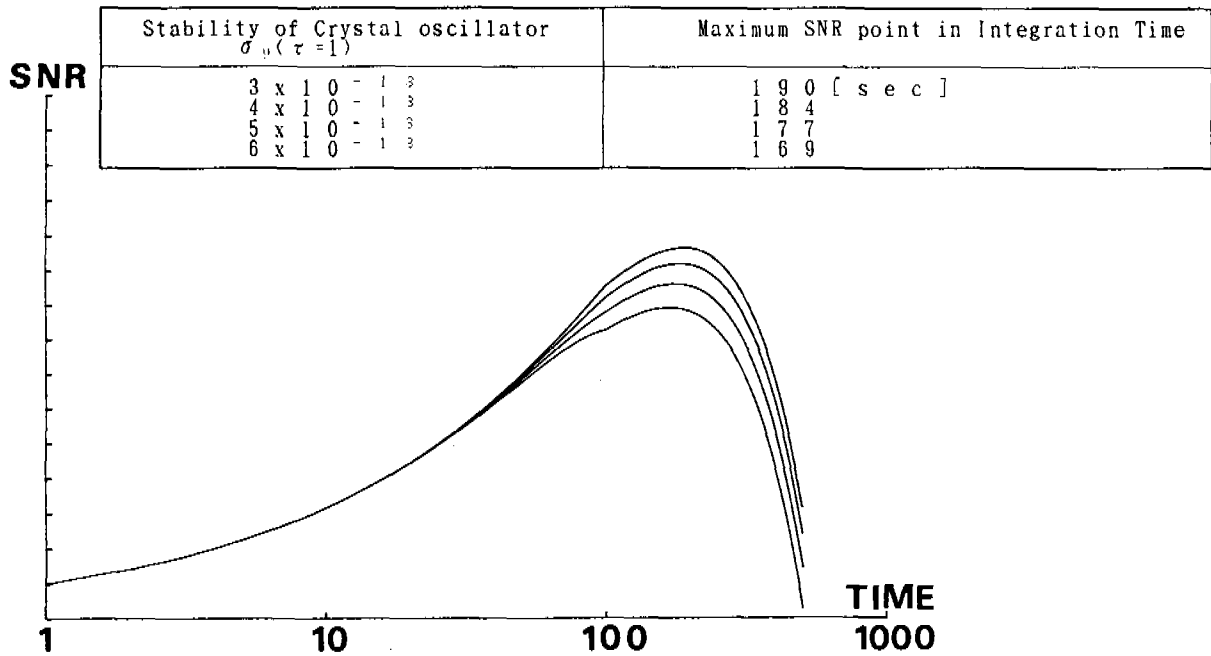

Fig. 9 (a) Estimated SNR* coherence (fixed Cesium stability)

Fixed stability of the Crystal Oscillator [$\sigma_y(\tau=1) = 4 \times 10^{-13}$]

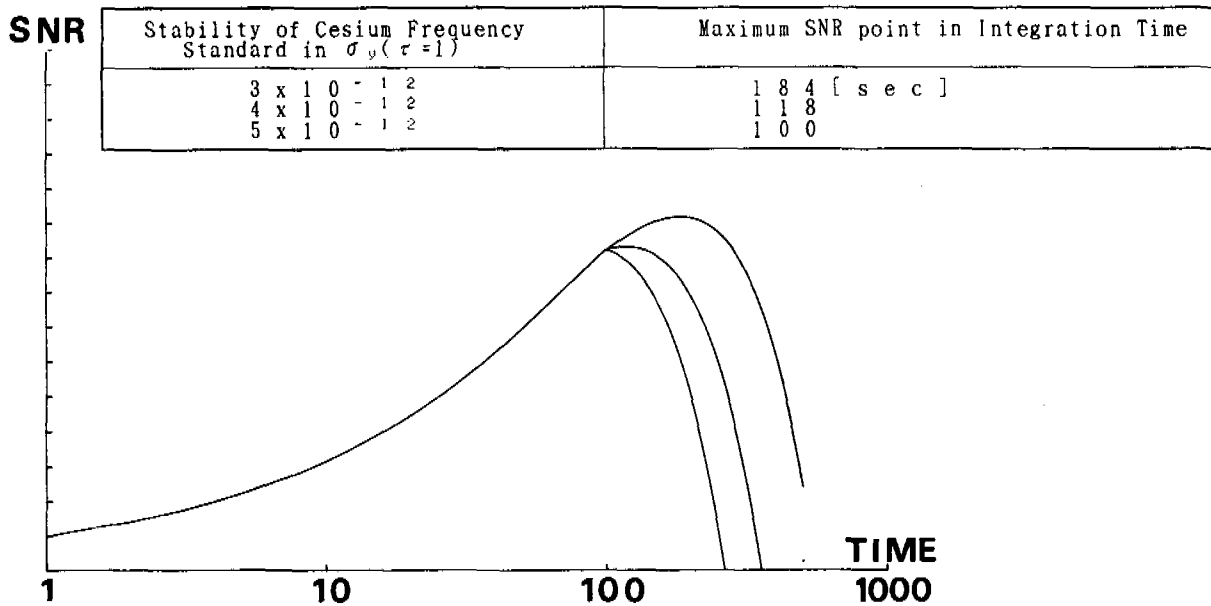

Fig. 9 (b) Estimated SNR* coherence (fixed Crystal stability)

Table 1 Atmospheric fluctuation in Allan standard deviation

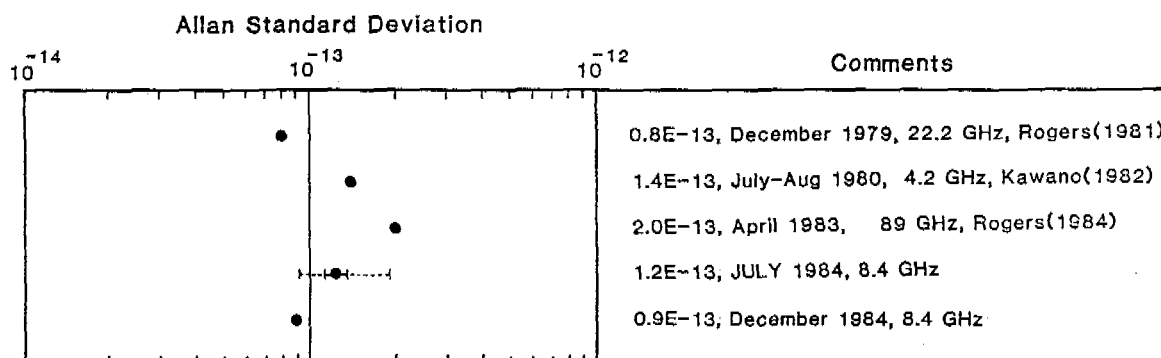

Table 2 Observed baseline components in 55km baseline experiment

	X	σ_x	Y	σ_y	Z	σ_z	B	σ_B
JEG-5	-3957171.259	0.020	3310237.094	0.017	3737709.499	0.022	54548.556	0.007
CASE-I	-3957171.290	0.089	3310237.040	0.082	3737709.506	0.093	54548.502	0.026
CASE-II	-3957171.302	0.075	3310237.085	0.061	3737709.514	0.077	54548.522	0.021
CASE-III	-3957171.377	0.112	3310237.141	0.099	3737709.596	0.110	54548.522	0.031

* in [m]

JEG-5 : Using Hydrogen maser, integration time(80 to 300sec) is dependent on source.

CASE-I : Integration Time is same as using Hydrogen Maser(80 to 300sec).

CASE-II : Integration Time is fixed in 120sec.

CASE-III : Integration Time is fixed in 60sec.