

# Simultaneous Transmission of a Frequency Reference and a Time Code Over a Single Optical Fiber\*

G. Lutes and M. Calhoun  
Jet Propulsion Laboratory  
California Institute of Technology  
4800 Oak Grove Drive  
Pasadena, CA 91109

## Abstract

The Apollo communications station is located at the JPL/NASA Deep Space Communications Complex at Goldstone California. It supports the manned Shuttle flights and Earth-orbiting scientific and communications satellites. This station needs precise frequency and timing references to perform its various tasks. In the past the station used a local Cesium clock to keep track of time which was established with a Loran-C receiver. The station's frequency and timing system has recently been upgraded to improve accuracy and reliability. In the new configuration, a 5 MHz frequency reference and a NASA 36-Bit time code are provided to the station from a central frequency and timing facility located 10 kilometers away. Both signals are transmitted from the frequency and timing facility to the Apollo station over a single optical fiber using a slightly modified commercial fiber optic link. This paper describes this dual channel fiber optic transmission system and gives its performance.

## INTRODUCTION

The Apollo Deep Space Station (DSS-16) is located at the JPL/NASA Goldstone Deep Space Communications Complex (DSCC) in the Mojave Desert near Barstow, California. This station supports manned shuttle flights, Earth orbiting scientific satellites, and communications satellites. The Apollo station requires exacting frequency and timing references for precise measurements needed for spacecraft navigation and various science experiments.

Apollo station's frequency and timing system is being upgraded to improve its stability and accuracy and to lower its maintenance and operating costs. The upgrade will also improve the stations synchronization to the central frequency and timing facility and thus to the other stations in the Goldstone complex.

The upgrade consists of a dual channel fiber optic link which provides improved frequency and timing signals to the Apollo station from the complex's central frequency and timing facility. The fiber optic link transmits a 5 MHz reference frequency and a NASA 36 bit time code simultaneously on a single

---

\*This work represents the results of one phase of research carried out at the Jet Propulsion Laboratory, California Institute of Technology, under contract with the National Aeronautics and Space Administration.

fiber over a distance of 10 kilometers from the central frequency and timing facility to the Apollo station. This paper describes the fiber optic link consisting largely of commercial assemblies and compares the quality of the new frequency and timing reference signals to the quality of the previous frequency and timing reference signals.

## **PREVIOUS FREQUENCY AND TIMING REFERENCE SIGNAL SOURCES**

Previous frequency and timing reference signals used at the Apollo station were derived from a WWV receiver, a LORAN-C receiver and a Cesium frequency standard. The WWV receiver was used to determine time within 12 ms eliminating the LORAN-C ambiguity. LORAN-C was then used to refine the time setting to within 10 microseconds. The time was checked against a one second tick transmitted over a microwave link from DSS-12. Using this equipment, the time could be set to within about 10 microsecond relative to UTC<sup>[1]</sup>. The Cesium frequency standard generated the stations frequency reference and maintained time between updates.

## **NEW FREQUENCY AND TIMING REFERENCE SIGNAL SOURCES**

The frequency and timing signals to be used in the Apollo station's new frequency and timing system are provided by the Goldstone DSCC's central frequency and timing facility. The frequency and timing facility is located in the centralized Signal Processing Center (SPC) located 10 kilometers from the Apollo station.

The 5 MHz frequency reference is provided by one of two H-masers which reside at the centralized frequency and timing facility. The second H-maser is a redundant hot spare. The frequency stability of the H-maser is about  $1 \times 10^{-15}$  for 1000 second averaging times.

The time reference is a GPS receiver which is also located at the central SPC. At the SPC the time can be set to within 100 ns relative to UTC. Time is periodically transferred to a time code generator which generates a NASA 36 bit time code. The time code generator uses the H-maser frequency reference to maintain time between the periodic updates.

The two frequency and timing signals from the SPC are transmitted on a single optical fiber to DSS-16 where they are used as the stations frequency and timing references.

## **THE FIBER OPTIC DISTRIBUTION SYSTEM**

Fig. 1 is a block diagram of the fiber optic frequency and timing distribution system. There is a signal combiner at the input which adds the frequency reference signal and time code signals together into a single signal path. This composite signal is applied to the input of a commercial fiber optic link which transmits the composite signal to the far end of the link. The fiber optic receiver detects the received composite signal and provides the input to a diplexer which separates the frequency reference signal from the time code signal. The signals are then amplified to the desired levels.

The input signal combiner has two inputs, one for the time code, and one for the 5 MHz frequency reference. The time code passes through an active low-pass filter and an amplifier. The low pass filter eliminates high frequency components of the time code above 10 kHz. The signal out of the filter goes to one port of a commercial resistive signal combiner. This signal combiner is of the resistive type to minimize intermodulation distortion which is excessive in transformer type combiners.

The 5 MHz frequency reference signal passes through an isolation amplifier. This amplifier prevents time code signals from feeding back into the frequency reference source which would result in cross modulation between the two signals. After passing through the amplifier the signal goes to the other port of the signal combiner.

The signal out of the signal combiner goes to the fiber optic link which transmits it to the Apollo station. The fiber optic link is a Wavelink model 3290 manufactured by the Grass Valley Group, a subsidiary of Tektronix, Inc. This link utilizes FM pulse modulation. The optical carrier, which is emitted by a laser diode, is AM modulated with a pulse at a subcarrier frequency of 24 MHz. The signal to be transmitted is applied to the FM modulator which frequency modulates the 24 MHz subcarrier. At the receiver end of the link the subcarrier signal is AM detected with a photodiode detector. The transmitted signal is recovered from the detected subcarrier with a frequency discriminator.

When the signal transmitted by the fiber optic link was first tested for frequency stability there was a hump in the Allan deviation which couldn't be accounted for. Further investigation identified the source of the hump. It was frequency modulation generated by the thermal control circuit which stabilized the temperature of the FM modulator in the fiber optic transmitter. This control circuit used pulse width modulation to control the heater. The switching period was around 0.07 Hz.

In an attempt to eliminate the frequency instability resulting from the thermal control circuit it was modified to work as a linear feedback circuit. This was accomplished by replacing a capacitor in the feedback loop filter with a larger value capacitor. This modification successfully eliminated the hump in the frequency stability and resulted in a lower Allan deviation.

Cross modulation products were reduced by adjusting the modulation index and input signal levels in the transmitter. This resulted in the best frequency stability and lowest Allan deviation.

A resistor was changed in the output circuit to modify the output impedance of the receiver from 75 ohms to 50 ohms. Otherwise the receiver was unmodified.

The receiver's output signal goes to a diplexer which separates the 5 MHz frequency reference from the NASA 36 time code. In the diplexer the time code signal passes through an active low-pass filter with gain and then to the output connector. The 5 MHz reference signal is amplified and partially filtered by an amplifier with a low frequency cutoff of 100 kHz.

A quartz frequency standard is used as a filter at the output of the fiber optic link. It is locked, in a 1 Hz bandwidth feedback loop, to the 5 MHz reference frequency from the diplexer. This filter eliminates the time code from the frequency reference signal and reduces its noise bandwidth. The quartz frequency standard is a model 1054A manufactured by FTS, Inc.

## PERFORMANCE MEASUREMENTS

### Thermal Coefficient of Phase Delay

The change of phase delay through the terminal equipment resulting from a temperature change was measured to determine its Thermal Coefficient of Phase Delay ( $TCD_{\phi}$ ).  $TCD_{\phi}$  is given in degrees phase change per  $^{\circ}\text{C}$  change in temperature.

Knowing the value of  $TCD_{\phi}$  is important because it can be used to predict Allan deviation if the temperature versus time function is known for the assembly environment.

To measure  $TCD_{\phi}$  the assembly was placed in an environmental test chamber with a temperature range of  $15^{\circ}\text{C}$  to  $35^{\circ}\text{C}$ . The temperature in the test chamber was then adjusted to an arbitrary reference temperature of  $15^{\circ}\text{C}$ . The phase across the assembly under test was measured at the operating frequency of 5 MHz. The temperature of the test chamber was then changed in  $5^{\circ}\text{C}$  steps. After each temperature change the temperature of the assembly under test was allowed to stabilize then another phase measurement was made. The results were then evaluated.

The measured  $TCD_{\phi}$  of the transmitter terminal equipment including the fiber optic transmitter, and the signal combiner is 0.12 degrees phase per  $1^{\circ}\text{C}$  change in temperature. For the receiver terminal equipment including the fiber optic receiver, the diplexer, and the clean-up loop the  $TCD_{\phi}$  is 0.1 degrees phase for a  $1^{\circ}\text{C}$  change in temperature.

### Thermal Coefficient of Delay for Fiber Optic Cable

The Thermal Coefficient of Delay (TCD) for cables is usually expressed in change per unit length and given in parts-per-million per  $^{\circ}\text{C}$  (ppm/ $^{\circ}\text{C}$ ). Loose tube single-mode fiber optic cable is used in this installation. Its TCD has previously been measured and found to be 7 ppm/ $^{\circ}\text{C}$ .

The delay variations through the buried fiber optic cable at Goldstone have been measured. It was found to be less than 50 picoseconds total variation over 58 kilometers for a period of several days. These measurements were taken when the day to night temperatures in the area varied from about  $43^{\circ}\text{C}$  during the day to about  $15^{\circ}\text{C}$  at night. From this data it is assumed that the delay variations in the fiber optic link are negligible compared to the specified time stability, of 100 ns.

### Signal-To-Noise Ratio (SNR)

Because FM modulation is used the SNR of the received signal is virtually constant until the loss in the FO cable and connectors is 28 dB which is equivalent to a transmission distance of 56 km. No signal is received when 28 dB loss is exceeded.

### Differential Phase Noise

Differential phase noise is a measure of phase noise added to a signal by the transmission system. It is often defined as double sideband rms phase noise density and is given in dB below the carrier in a one Hz bandwidth (dBc/Hz). The carrier referred to is the transmitted signal.

Differential phase noise is measured across the transmission system. The input signal is used as the reference and the output signal phase noise is measured relative to the input. The phase noise of the signal used as a reference therefore does not contribute to the differential phase noise of the transmission system. The phase noise measured in this manner is only the phase noise contributed by the transmission system.

A block diagram of the measurement system used to measure differential phase noise is shown in Fig. 2. Power splitter splits a 5 MHz input reference signal into two signals. One signal is applied through a phase shifter to a phase detector's LO port. The other signal is applied directly to the phase detector's RF port. The signals applied to the phase detector's LO and RF ports are adjusted to the manufacturer's suggested levels, with the use of appropriate amplifiers and attenuators. The phase shifter is adjusted to obtain  $90^\circ$  phase difference between the phase detector's input signals. A phase detector's output voltage is zero for  $90^\circ$  phase difference between its input ports.

To measure the phase noise, the resultant baseband noise out of the phase detector's output port is applied through a low pass filter to the input of a low frequency spectrum analyzer. The phase noise spectrum is read from the spectrum analyzer and recorded.

Table 1 gives the requirements for the new frequency reference signal. Its measured differential phase noise is given in Fig. 3. The time code was transmitted during the phase noise measurement and caused a slight rise in the phase noise between 100 and 1,000 Hz.

## Allan Deviation

A block diagram of the system used to measure Allan variance is shown in Fig. 4. An offset generator offsets a 100 MHz frequency reference signal generated by a H-maser frequency standard by 1 Hz. The offset generator used was designed and constructed at JPL. The output of the offset generator drives the LO port of a mixer.

A 5 MHz signal from the same H-maser is transmitted through the fiber optic link along with a NASA 36 time code. At the output of the fiber optic link a tracking filter reduces the noise bandwidth of the transmitted 5 MHz signal to 1 Hz. It also separates the digital time code signal from the 5 MHz frequency reference signal.

The 5 MHz signal out of the tracking filter drives a times 20 frequency multiplier which multiplies the 5 MHz up to 100 MHz. The resulting 100 MHz signal drives the RF port of the mixer. The output of the mixer is the difference frequency between the 100 MHz + 1 Hz from the offset generator and the 100 MHz signal from the times 20 frequency multiplier. This signal which is nominally 1 Hz passes through a low pass filter to an Allan variance test system. This system precisely measures the time interval between zero crossings of the 1 Hz signal from the mixer. The system uses this data to calculate the average frequency between the zero crossing intervals. It then evaluates the equations for Allan<sup>[2]</sup> variance and Allan deviation and plots the results.

The Allan deviation for the frequency reference signal provided by the fiber optic distribution system is compared to the Allan deviation of the previously used Cesium<sup>[3]</sup> frequency standard in Fig. 5.

## CONCLUSION

The stability of the frequency and timing references for the DSS 16 DSCC was improved considerably with the use of a fiber optic link which was assembled primarily from commercial assemblies. This link transmits a 5 MHz reference frequency signal and a NASA 36 time code simultaneously over a 10 km distance on a single optical fiber.

Measurements on the stability of the signals supplied by this fiber optic link verified that the signals are much better than the signals used previously.

The stability of the signals supplied by this fiber optic link is not as good as the stability of signals transmitted by custom fiber optic links used elsewhere in the DSN. However, the system described in this paper is relatively inexpensive and can provide reference signals which are nearly as good as the best reference signals used in the DSN.

## REFERENCES

1. Conversation with Paul Kushmeider, Nov. 28, 1989.
2. D. W. Allan, "Statistics of Atomic Frequency Standards," Proc. IEEE, vol. 54, pp. 221-230, February 1966.
3. Manual for the Hewlett Packard 5061B Cesium frequency standard.

TABLE I

### SPECIFICATIONS FOR THE NEW FREQUENCY REFERENCE

Amplitude:	1 volt rms,	50 ohms
Harmonics:		-40 dBc
Non Harmonics:		-80 dBc
SSB Phase Noise	(1 Hz Bandwidth):	
	Offset From the Signal	
	1 Hz	-86 dBc
	10 Hz	-124 dBc
	100 Hz	-130 dBc
	1 kHz	-140 dBc
	1 kHz to 100 kHz	-140 dBc

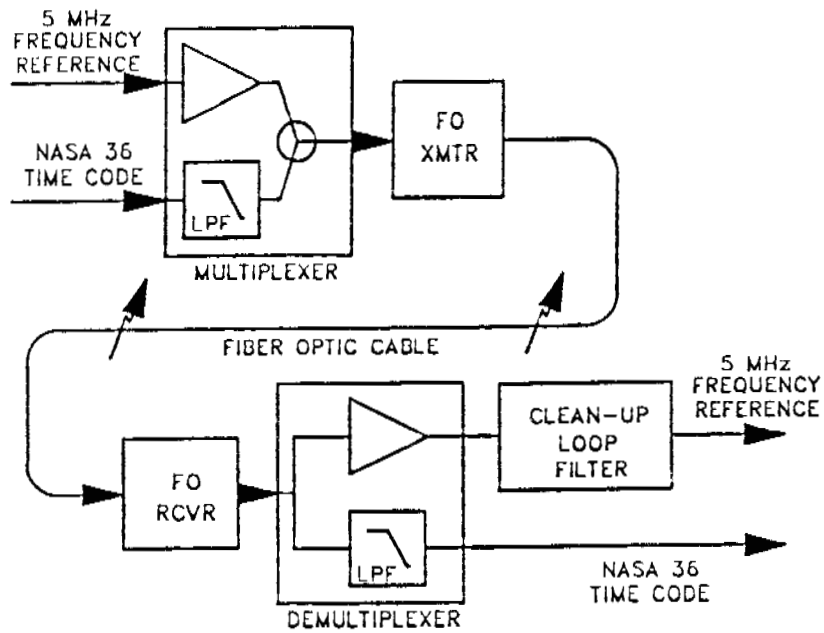

Figure 1. A block diagram of the fiber optic frequency and timing signal distribution system.

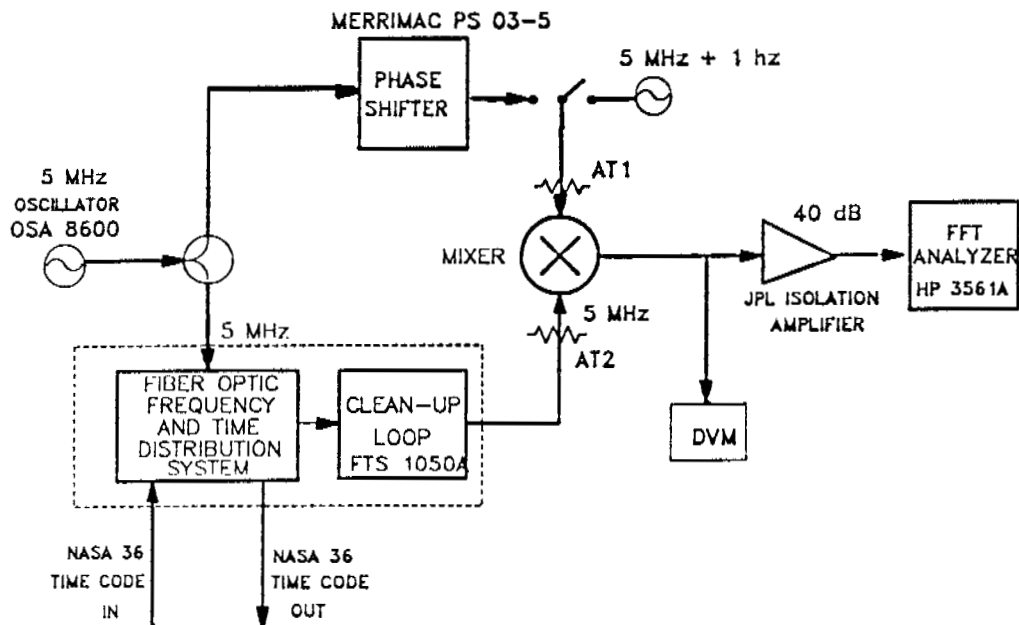

Figure 2. A block diagram of the differential phase noise measurement system.

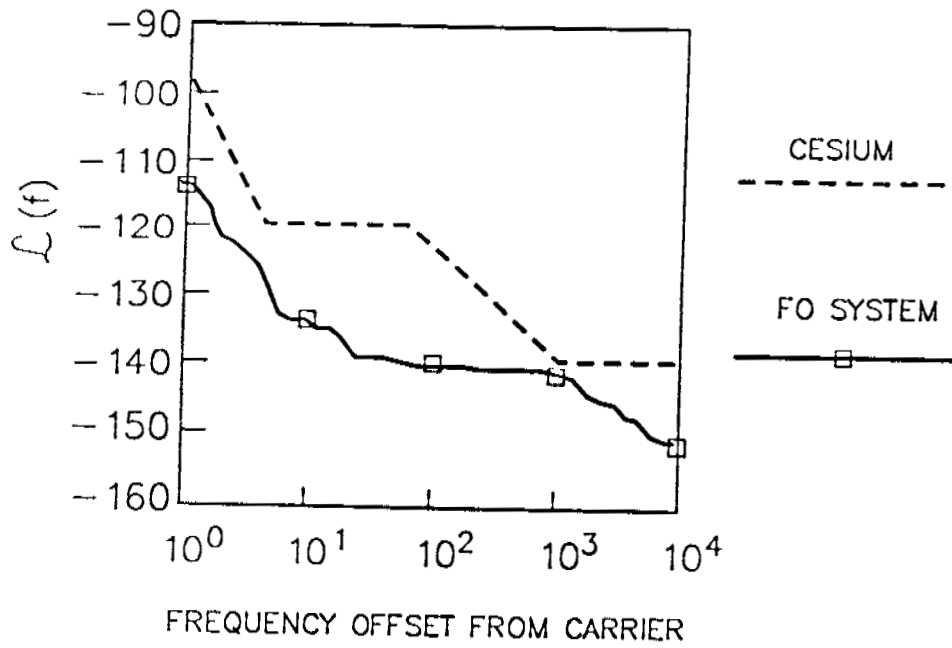

Figure 3. A plot of

- (a) differential phase noise for the fiber optic frequency and timing reference transmission system, and
- (b) the phase noise of the previously used Cesium frequency standard.

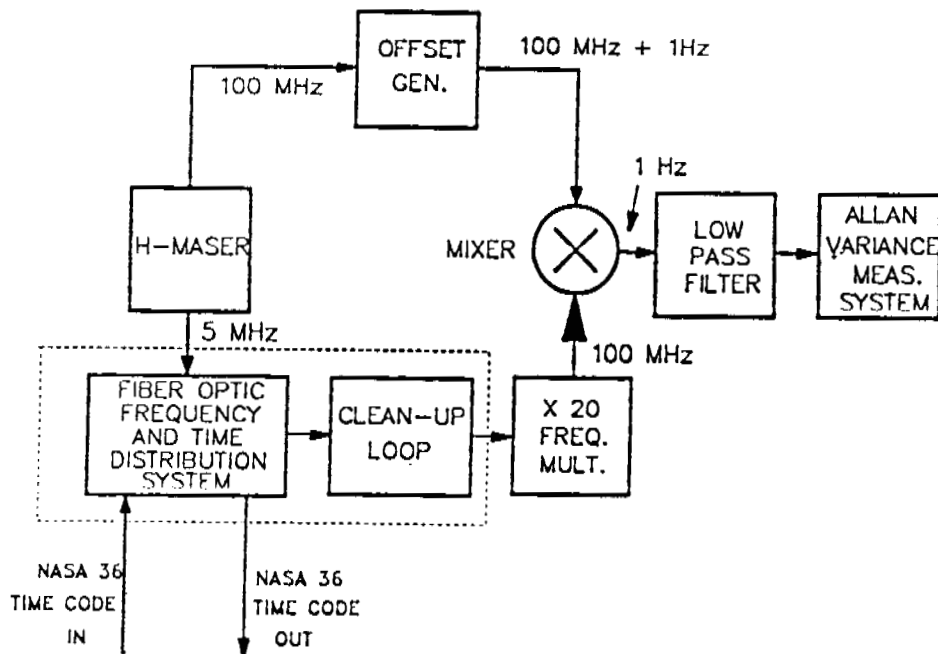

Figure 4. A block diagram of the system used to measure Allan variance.



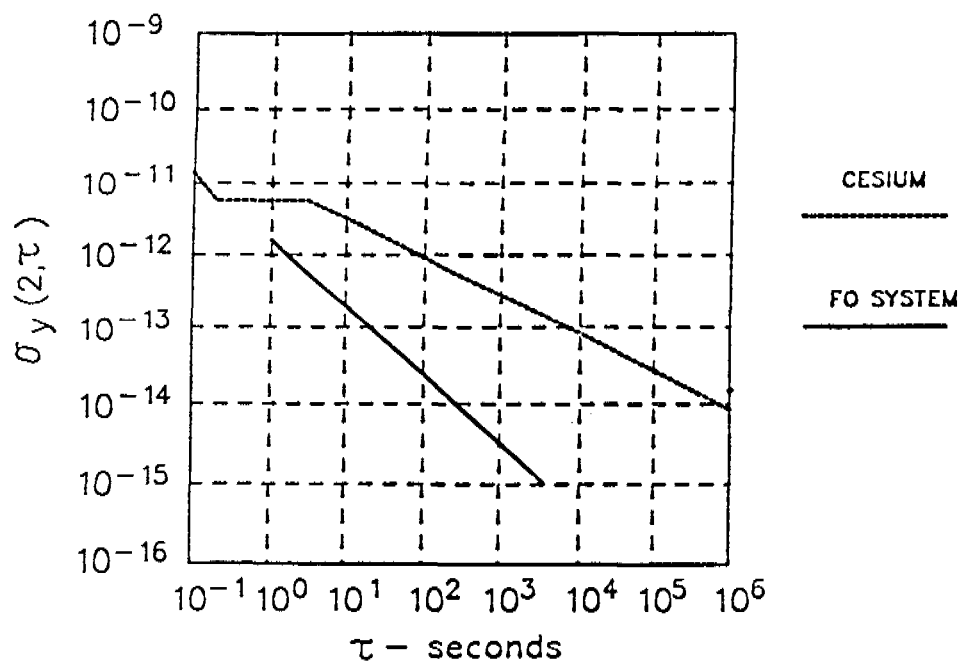

Figure 5. A plot of

- (a) the Allan deviation for the signal transmitted by the fiber optic distribution system,
- (b) the Allan deviation of the previously used Cesium frequency standard,

## QUESTIONS AND ANSWERS

**PAUL QUINN, ROCKWELL:** Did you find it necessary to phase lock the multiplexing frequency with your reference frequency?

**MR. CALHOUN:** No, there is no multiplexing, just analog addition.

**MR. QUINN:** There is no degradation due to that?

**MR. CALHOUN:** There was some cross-talk in the system just due to the non-linearities throughout the system, but I was able to separate the two signals at the analog de-multiplexer with virtually no degradation after I put the disciplined frequency standard in.

**MR. QUINN:** Does the filter take care of the errors due to multiplexing?

**MR. CALHOUN:** Yes, it does. The bandwidth on that filter, by the way, is one-half Hertz. It is a very narrow bandwidth tracking filter.