

THE NIST DIGITAL TIME SERVICE

J. Levine, M. Weiss, D.D. Davis, D.W. Allan, and D.B. Sullivan
Time and Frequency Division
National Institute of Standards and Technology
Boulder, Colorado 80303

Abstract

The NIST Digital Time Service is designed to provide computers with telephone access to time generated by the National Institute of Standards and Technology (NIST, formerly the National Bureau of Standards) at accuracies approaching 1 ms. Features of the service include automated estimation by the transmitter of the telephone-line delay, advanced alert for changes to and from daylight saving time and advanced notice of insertion of leap seconds. The ASCII-character time code operates with most standard modems and computer systems. The system can be used to set computer clocks and simple hardware can also be developed to set non-computer clock systems.

INTRODUCTION

The principal limitation to the accuracy of most methods of time dissemination is the uncertainty in the velocity of propagation of the information through the medium separating the transmitter and receiver. The delay, which is typically on the order of milliseconds, depends both on the physical length of the path and on the group velocity of the signal, and neither of these is well known in general. Either the path length or the group velocity is likely to change with time, so that real-time measurements of the transit time are generally required if the highest accuracy is to be realized. The telephone system provides a unique environment in this respect, since such measurements can be made using simple hardware. Using the telephone system for time dissemination is also desirable since telephone service is already widely available.

If a passive receiver is replaced by an active transponder, the time delay along the path can be determined from the transmission end by sending a pulse to the user and measuring the delay until the echoed pulse returns. Half of this round trip delay is the time for the signal to reach the user assuming that the communication medium is reciprocal (i.e., that the delay is the same in both directions). This is not always the case for atmospheric paths because of fluctuating multi-path effects and asymmetries in the antennas, and it was not always the case in the past for telephone circuits. The telephone carriers now prefer to route both directions of transmission along the same path. As will be seen later in this paper, tests indicate that the telephone path is highly reciprocal.

With this as background and with growing interest in millisecond-level synchronization of computers, NIST has developed a simple telephone system for automated setting of clocks in digital systems. This service is called the Automated Computer Time Service (ACTS). The system makes no demands on the receiver and will function with both passive receivers and active transponders. A passive receiver consists of a modem and a terminal, computer or other display device. An active transponder consists of the same hardware with the additional capability of being able to echo the received messages back to NIST using either hardware or software methods. For either type of system, the modem must conform

to either the Bell 103A standard for frequency-shift keying at 300 bits/s or the Bell v212a standard for phase-shift keying at 1200 bits/s. The terminal, computer or display device must recognize the standard ASCII code transmitted with 7 data bits, space parity and 1 stop bit.

The current telephone number for the service is (303) 494-4774. This is not a toll-free number. The following sections describe the service in more detail including discussion of

1. the operation of the service,
2. the reliability of the transmission system and
3. software and hardware which have been developed for the user end.

OPERATION OF ACTS

Transmission Formats

The transmission format at 1200 bits/s is shown in Fig. 1.

- a. The column labeled MJD is the Modified Julian Day number, which advances by 1 at 0000 Coordinated Universal Time (UTC) every day. The MJD corresponding to 1 January 1989 was 47527.
- b. The next six numbers give the Coordinated Universal time as: years since 1900, month, day, hour, minute and second. Coordinated Universal Time is the official international time and was formerly called Greenwich mean time.
- c. The column labeled DST is a flag used to specify if a correction for daylight saving time is required now or is imminent. This flag is valid for most of the continental United States. If DST is 00 then standard time is in effect. If DST is 50 then daylight saving time is in effect. If DST is between 99 and 51 then a transition to daylight saving time is approaching. Daylight saving time will be in effect at 2:00 (2:00 a.m.) local time on the day when the count reaches 51. If DST is between 49 and 01 then a transition from daylight saving time back to standard time is approaching. It will arrive at 2:00 (2:00 a.m.) local time on the day when the counter is 01. In either transition situation, the counter is decremented at 00:00:00 (midnight) UTC every day.
- d. LS is the leap-second flag and is normally 0. It will be set to 1 to indicate that a leap second is to be added following 23:59:59 UTC on the last day of the current month. This second will be named 23:59:60 UTC, and the second following it will be 00:00:00 of the following day. The LS flag will be set to 2 to indicate that a second is to be dropped at end of the last day of the current month. The second following 23:59:58 UTC will be 00:00:00 UTC of the next day. Added leap seconds are generally required about every 18 months to maintain the coordination of UTC; it is unlikely that seconds will be dropped in the foreseeable future.
- e. DUT1 is the approximate difference between a time scale defined in terms of the rotation rate of the earth (UT1) and UTC. That is, $DUT1 = UT1 - UTC$. The difference is given to the nearest tenth of a second.
- f. msADV is the advance of the on-time marker in milliseconds. The center of the stop-bit of the on-time marker leaves the transmitter early by this amount so as to arrive at the user on-time.

- g. OTM is the on-time marker. It is either '*' or '#' as discussed below. The center of the stop-bit of this character is intended to arrive at the user at the time specified by the previous characters on the same line.

A help message is available if the user sends a question mark early in the transmission. This, however, preempts the transmission of time information for the rest of that call.

The transmission format at 300 bits/s is similar, but there is not enough time to send the entire message. The transmission consists of the UTC time in hours, minutes and seconds, the current advance in milliseconds and the on-time marker. In the future, alternating halves of the full message may be sent every second together with an on-time marker, so that the full date can be decoded every two seconds.

Modes of Operation of the Service

Depending on the user equipment, the ACTS service provides three modes for checking and/or setting computer clocks.

- In the simplest form of the service, a passive user receives the time code and the on-time marker/character but does not echo the received message.

In this case, an advance of 45 ms is used for all transmissions. The OTM should arrive at the user within 100 ms of the correct time unless the connection is routed through a satellite.

- If the user echoes all characters back to NIST, the round-trip line delay of the on-time marker will be used to adjust the advance of subsequent transmissions. The accuracy in this mode should be better than 10 ms and the repeatability is about 1 ms.
- If 300 bit/s modems are used and the user echoes all characters back to NIST, the slower transmission speed means that the full time code is not transmitted, but the measured delay is likely to be more accurate. Our experience indicates that the accuracy will be approximately 1 ms.

In any of these modes, the maximum connection time is 55 s. If all of the lines are busy at any time, the oldest call will be terminated if it has been on line more than 15 s, otherwise the call that first reaches 15 s is disconnected.

Reliability

To help ensure that ACTS never sends the wrong time, the system has triple redundancy and special self checking to enhance reliability and to increase the volume of calls that can be handled. The basic unit (see Fig. 2) consists of three time-code generators, each with a complete system for generating the time code and disseminating it through a separate modem to one of the telephone lines. Each of the time-code generators receives an independent time signal from a different clock in the NIST time scale. The time code needs to be initialized by an operator, but is automatically updated by the hardware after that. The power supply for the system is backed up by batteries so that the internal clocks do not lose time during a power failure.

Each time-code generator constantly compares its own time code with the codes of the other two, and participates in majority voting on the correctness of these codes. The time code is transmitted at 100 bits/s from each generator to the other two. This code contains all of the information transmitted through the telephone line. Each generator compares the bits of the two incoming codes with its own code and flags a generator as bad if any one disagrees with the other two. The flag of one generator declaring another bad is passed to a central control module as a vote against the offending generator. If any two of the generators vote against any single generator, the loser is taken off line. If all three disagree with one another, all three are disabled.

Each time-code generator receives a timing signal from the other two and compares these signals with its own internal time. If either time difference is larger than $15\mu\text{s}$, this is reported to the control module. Again, the votes are counted by the control module. A vote of two to one takes the loser off line and disagreement among all three disables all of them.

If an individual time-code generator finds either a code or a time error it sounds an audible alarm. If there is total disagreement among the three generators, all three generators are taken off line and the lines to these generators are set so that a caller will receive a busy signal. The system is also connected to a special alarm at the Boulder NIST security office and signals that office if problems develop. This office then contacts one of the system operators, either at work or at home. To facilitate operations and service, the system can be operated remotely using extensive control and diagnostic functions.

The ACTS system can be expanded in three-line units, each operating independently in the manner described above. If an entire three-generator unit is taken off-line, then the effect is to reduce the number of available lines by three. The desired effect is that the system transmits nothing rather than transmitting a code or time marker which is in error.

USER SOFTWARE AND HARDWARE

Software

We have developed some example ACTS software which runs on a number of popular computers.¹ There has been no attempt to be comprehensive in coverage of different computers, but rather to focus on a few example packages which can then be adapted to other machines. The NIST software provides for automated dialing, selection of time zone, selection of mode of operation, echoing of the OTM, setting of the computer clock, archiving of clock offset, and transmission to the port of the computer of a signal which can be used to produce an external time pulse coincident with the OTM. The program is written in a modular fashion so that additional features, such as a graphical presentation of the time-difference data or a more comprehensive statistical analysis of the performance of the local clock, can be added easily. This example software (which includes source code) is available on a 5.25-inch, 360 kbyte MSDOS diskette along with instructions for \$35.00. To order this software contact:

¹Example software is available for IBM PC/XT/AT and compatible systems, for the DEC PDP-11, and for Sun systems. (These trade-names are used for identification purposes only and no endorsement is implied.)

NIST Office of Standard Reference Materials
B311 - Chemistry Building
Gaithersburg, MD 20899
(301) 975-6776

Specify that you want RM 8101, software for Automated Computer Time Service.

Hardware

Using software developed by NIST, the PC/XT/AT compatibles will deliver a signal coincident with the OTM to the parallel printer port. The very simple circuit shown in Fig. 3 can be used to convert this to a positive pulse. This might be useful for synchronizing an external system or for starting or stopping a counter in a precise measurement of frequency (see Section 5). A second circuit which we have tested (see Fig. 4) echoes all characters from the user and provides an external pulse when the OTM is received. This circuit, which allows ACTS to calibrate the phone line and advance the OTM accordingly, requires an external modem, but does not require a computer. To use this circuit, the user must first manually establish the telephone connection with NIST.

TIMING ACCURACY

We have evaluated the performance of the ACTS system using both satellite and ground-based telephone circuits. The satellite test was performed between the NIST radio station WWVH in Hawaii and our laboratory in Boulder, Colorado; the ground-based test used a local telephone call in Boulder.

In both tests, we use either the circuit of Fig. 4 or a personal computer running our software to produce a pulse each time the on-time marker arrives at the receiver. We measure the time differences between these pulses and the ticks of a local time standard. These tests are repeated at different times of the day and using different brands of modems.

Consecutive measurements over both the satellite and local telephone connections showed a repeatability of $\pm 1ms$ at both 300 and 1200 bits/s. It suggests that both satellite and local telephone connections are reciprocal to a very high degree.

The accuracy of the arrival time of the on-time marker was measured using several different brands of modems. All of the tests used local telephone connections. At 300 bits/s, the offset of the on-time marker was not more than $\pm 2ms$ for any modem tested. At 1200 bits/s, different brands of modems resulted in offsets of up to $\pm 7ms$, which is significantly larger than the repeatability using any one modem. These offsets result from the difference in the group delay between the transmit and receive portions of the modem.

The accuracy of the satellite connection to Hawaii was measured using a single modem at both speeds. We measured an accuracy of 1 ms using 300 bits/s and 6 ms using the 1200 bit/s protocol. These values were stable from day to day to within the repeatability quoted above, and suggest that the satellite path is also reciprocal to a very high degree.

A more detailed discussion of the error budget for the system can be found in Levine et al.^[1]

APPLICATIONS

One of the most important applications for ACTS is the maintenance of accurate time within a digital computer or some digital hardware with a microprocessor. This may be especially important in a network where a number of computers independently tag events with the date and time and then share their information.

A second application is the measurement of frequency. Here pulses coincident with the OTM are used to start and then stop a counter which counts the output of the oscillator under test. If the start and the stop pulses are separated by one day, then the system can yield a frequency-measurement accuracy of about 0.01 ppm.

DISCUSSION AND CONCLUSIONS

NIST is now committed to long-term operation of a new Automated Computer Time Service. The format is now fixed, except for a change which will modify the 300 bit/s format to transmit the entire time/date message every 2 s. The system will be expanded as the number of calls increases. The telephone number for the service is (303) 494-4774. All of the lines will be connected to a telephone rotary switch so that they can be reached by dialing this number. This number is not toll-free.

The system was designed to make operation at the user's end particularly simple. With telephone-line delay measured at the NIST end, the user needs only a modem and a computer or some other digital system to access NIST time at accuracies of up to 1 ms. Example software and hardware has been developed by NIST, and the software is available for a small charge.

The system can be used to set digital clocks, or to perform frequency calibration at an accuracy of 0.01 ppm for a one day measurement.

REFERENCES

- [1] J. Levine, M. Weiss D. D. Davis, D. W. Allan and D. B. Sullivan, The NIST Automated Computer Time Service, J. Res. of NIST, 94, 311 - 321 (1989).

? = HELP
 National Institute of Standards and Technology
 Telephone Time Service

(1 second pause here)

MJD	YR	MO	DA	H	M	S	D	L	D	ST	S	UT1	msADV	OTM
47222	88	03	02	21	39	15	83	0	+	.3	045.0	UTC(NIST)	*	
47222	88	03	02	21	39	16	83	0	+	.3	045.0	UTC(NIST)	*	
47222	88	03	02	21	39	17	83	0	+	.3	045.0	UTC(NIST)	*	
47222	88	03	02	21	39	18	83	0	+	.3	045.0	UTC(NIST)	*	
47222	88	03	02	21	39	19	83	0	+	.3	037.6	UTC(NIST)	#	
47222	88	03	02	21	39	20	83	0	+	.3	037.6	UTC(NIST)	#	
etc..etc...etc.....														

Figure 1. Time code and time marker transmitted by ACTS at 1200 bits/s. The abbreviations are as follows: MJD = Modified Julian Date, YR = Year, MO = month, DA = Day, H = Hour, M = Minute, S = Second, DST = Daylight Saving Time (a flag meaning that a change is coming), LS = Leap Second (a flag meaning a leap second is to be added), DUT1 = UT1 - UTC (earth rotation time minus coordinated universal time), msADV = milliseconds of advance of the time marker, OTM = On-Time Marker.

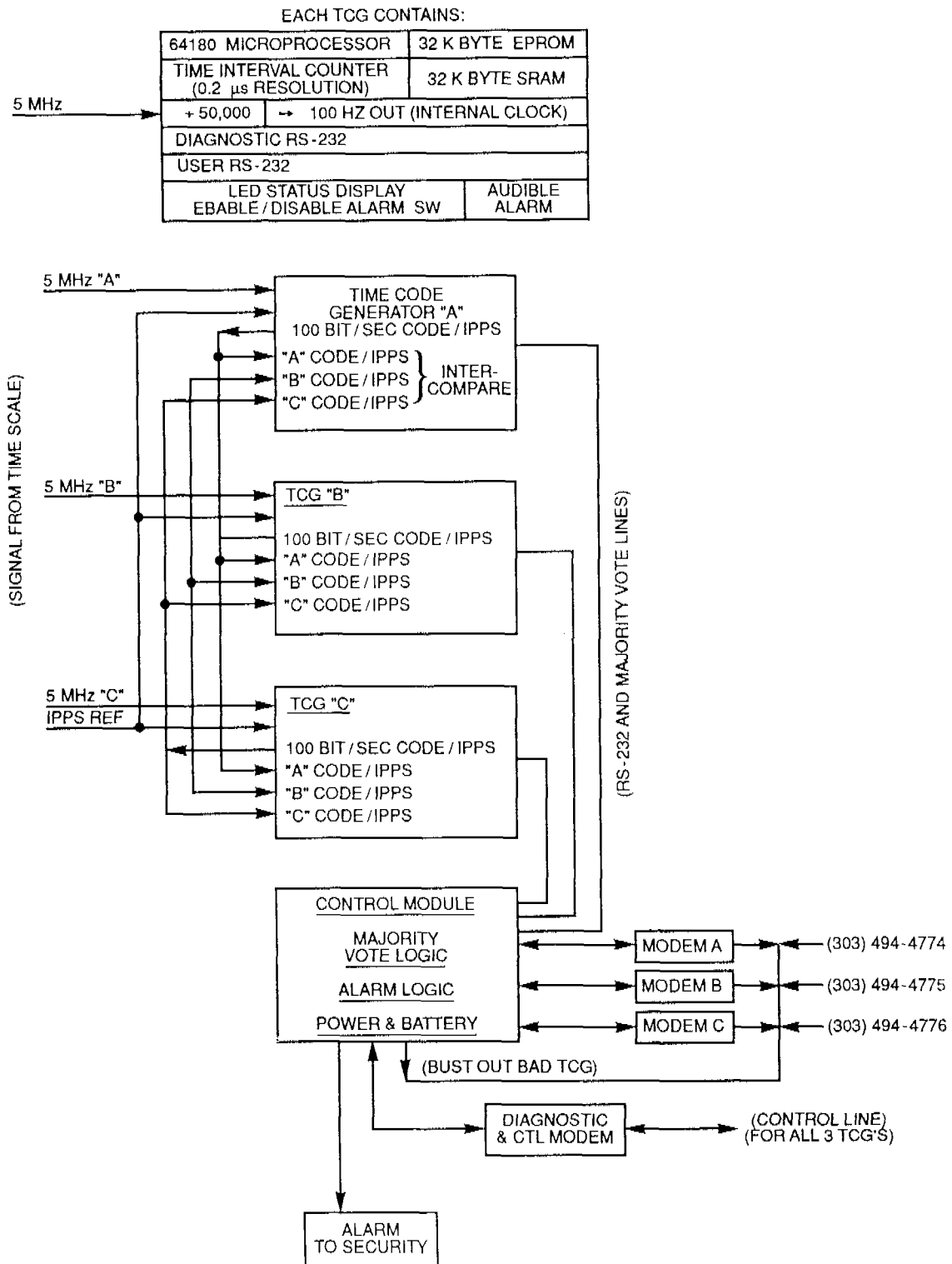

Figure 2. Block diagram of the ACTS transmitter including time-code generators and control module.

PC. INTERFACE TO PRINTER PORT
FOR IPPS OUT

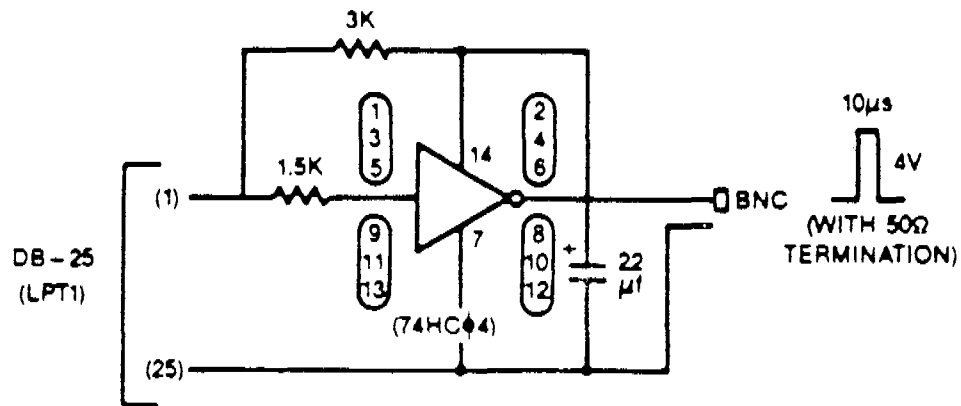

Figure 3. Simple circuit used to obtain a positive pulse coincident with the OTM from any PC/XT/AT compatible computer using the NIST software. The HCMOS inverter can be built directly into a DB-25 male connector.

