

AN AUTOMATIC MEASUREMENT SYSTEM FOR RF PULSE STABILITY PARAMETERS

Liu Xiaofan and Mao Ruida
Beijing Institute of Radio Metrology & Measurements
P.O.Box 3930, Beijing, P.R.China

ABSTRACT

This paper describes a new automatic system for measurement of transmitter stability parameters, esp. the frequency stability of RF pulses series, which can limit the performance of various coherent pulse radars. The practicability to characterize the stability of RF pulse series with interpulse variance in time domain and near-carrier phase noise in frequency domain is studied in the paper. The operation principle, system construction and calibration methods of quadrature dual channel frequency and phase discrimination system for the measurement of interpulse variance are discussed here. This system is effectively used in the measurement of stability of radar transmitters.

INTRODUCTION

The phase parameter is used to transfer information in most modern radar systems. Thus there are more and more requirements on high frequency stability and low phase noise. It becomes more important how to characterize and measure the stability of radar transmitters. Most of radar transmitters, however, do not use continuous wave (CW) but pulse-modulated wave, whose stability determines the general performance of radar systems. There is still no unanimous method in characterization of the carrier frequency stability on pulsed wave. And the measurement technique is much more difficult for pulsed wave than for CW. Therefore, some radar parameters, for example, improvement factor or visibility, are usually used to evaluate the stability of radar system, which is measured by self-check method.

The study on the frequency stability of pulse modulated wave started in 1960's. The microwave phase bridge was used to measure the additive phase noise of pulsed power amplifiers in microwave frequencies with high sensitivity[1] and is still used to measure the additive noise in amplifier transmitters. While the microwave frequency discrimination bridge is frequently used in measurement of oscillator transmitters, with microwave cavity[2][3] or delay[4][5] as frequency discriminators. After 1970's, computers are used for data processing in these systems[6]. A special equipment, which can measure transmitter stability parameters, such as frequency, phase, timing, pulsewidth and amplitude fluctuations, was developed by Milan afterward[7]. Beijing Institute of Radio Metrology and Measurements also works in this field.[8][9]

The measurement system raised in this paper still uses microwave phase bridge to measure interpulse phase fluctuation in amplifiers. The frequency stability of oscillation transmitters can be measured by IF quadrature dual channel technics. One of them is quadrature dual channel phase discrimination system, which can measure frequency / phase fluctuation automatically with fast sampler and digital convolution unit. A quick agile frequency synthesizer is developed to overcome the influence of frequency shift and realize the automatical frequency tracking. At the same time, another new way, named quadrature dual channel frequency discrimination bridge, has been developed in our laboratory. It is proved that the method combines the advantages of microwave frequency discrimination bridge and I.Q. branch technic in measuring the stability of RF pulses. Besides, other interpulse fluctuations of the parameters, such as amplitude, timing, and pulsewidth, can also be measured in this system.

In this paper the interpulse variance is raised to characterize the frequency stability of RF pulses in time domain. The video signals are acquired at high speed through A / D converter and DMA unit and fed into the computer for data processing. The measurement results of interpulse variance are given by the statistic treatment, and FFT is used to analyze the spectrum, which can be evaluated as the near carrier phase noise.

CHARACTERIZATION FOR FREQUENCY STABILITY OF RF PULSE SERIES

A variety of radars has a basic requirement on the frequency stability of their transmitters. The performance of Moving Target Indicator (MTI) radar can be defined by Improvement Factor(I), which is written:

$$I = \frac{\bar{S}_0}{S_i} CA$$

where CA = Clutter attenuation
 S_i = Input signal
 \bar{S}_0 = Output signal averaged over all target velocities

Any instability in radar transmitter can limit the Improvement Factor of MTI System. Because the radar signal will be cancelled between adjacent pulses to indicate the moving target signal submerged in clutter, the interpulse fluctuation of various parameters are vitally important. The relations between improvement factor limitations and interpulse fluctuations are listed as follows:

$$I_A = 20 \lg \frac{A}{\Delta A}; \quad I_\varphi = 20 \lg \frac{\pi}{2\Delta\varphi}; \quad I_f = 20 \lg \frac{1}{4\tau\Delta f}$$

$$I_t = 20 \lg \frac{\tau}{\sqrt{2}\Delta t}; \quad I_\tau = 20 \lg \frac{\tau}{\Delta\tau}$$

where A and τ are the amplitude and pulsewidth of RF pulses, and $\Delta A, \Delta\varphi, \Delta f, \Delta t$ and $\Delta\tau$ are respectively amplitude, phase, frequency, timing and pulsewidth fluctuations of RF pulses. The results are similar to that deduced separately by Skolnik[10] and Milan.

The interpulse instability in oscillators is reflected by frequency fluctuation mainly, while in amplifiers, that is reflected by phase fluctuation. The total improvement factor limitation is the combination, which can be written:

$$I_T = \frac{1}{\frac{1}{I_1} + \frac{1}{I_2} + \dots + \frac{1}{I_N}}$$

The visibility of Pulse Doppler Radar is determined by near-carrier phase noise of the transmitting signal. In order that the echo, which includes Doppler frequency shift f_d , will not be submerged by phase noise, the phase noise must be

$$S_\varphi(f_d) \leq V(f_d) - 10dB$$

It can be seen that it is possible to have an integrate characterization for the frequency stability of RF pulse series in radar transmitters.

The proper method is: using interpulse variance as the characterization for the frequency stability of RF pulse series in time domain, and near-carrier phase noise as that in frequency domain.

The interpulse variance is determined with the average square value of averaged frequencies in two adjacent pulses, as

$$\sigma^2 = \langle (\bar{F}_1 - \bar{F}_2)^2 \rangle$$

This expression is coincident with the first difference variance or cancellation of MTI radar. While, the near-carrier phase noise means the phase noise power spectrum density whose difference frequencies to the carrier are no larger than one half of the repeat frequency (i.e. $f_m \leq \frac{f_r}{2}$) in sampling function frequency spectrum of RF pulse series.

When sampling the output video signal at the rate of the pulse repeat frequency, the obtained data is a separate time series:

$$\Delta f(t_i) = \Delta f(t)|_{t=iT+T_0} \quad i = 1, 2, \dots, N$$

where N is sampling number, T is pulse repeat period, T_0 is synchronization delay.

After FFT transformation, this series is transformed into a frequency or phase series in frequency domain:

$$\Delta f(f_{mi}) = \Delta f(f_m) \Big|_{f_m - t \frac{1}{2NT}} \quad i = 1, 2, \dots$$

$$\varphi(f_{mi}) = \frac{\Delta f(f_m)}{f_m} \Big|_{f_m - t \frac{1}{2NT}}$$

The expression of interpulse frequency variance is

$$\sigma_f^2 = \frac{1}{N-1} \sum_{i=1}^{N-1} [\Delta f(t_{i+1}) - \Delta f(t_i)]^2$$

The power spectrum density of near-carrier phase noise is

$$S_\varphi(f_{mi}) = 20 \lg \frac{\varphi(f_{mi}) \tau}{\sqrt{\Delta B} T} \quad (dB / Hz)$$

In the formula, $\Delta B = \frac{1}{2NT}$ is the sampling interval in frequency domain.

Above all, this characterization method has three advantages:

- (1) It can characterize directly the performance of radars.
- (2) It is similar to the method for continuous wave [11] so that some measurement technique for CW can still be applicable [12].
- (3) It is convenient to make data processing by computer.

SYSTEM CONSTRUCTION AND OPERATION PRINCIPLE

Fig. 1 is the general block diagram of the measurement system. The subsystems to measure frequency, phase and amplitude are separated. These subsystems are connected to the same A/D sampler and data processing unit with an IBM-PC computer. The timing and pulsewidth are measured by a counter with analogue interpolation and transferred to computer through digital interface.

1. Quadrature Dual Channel Phase Discrimination

Quadrature dual-channel phase discrimination is a method to measure interpulse frequency stability, as shown in Fig. 2. The radio pulsed signal from transmitter is transformed twice to the fixed frequencies (300 MHz, 30 MHz) in order to broaden the frequency range. I.Q. quadrature video outputs are obtained by quadrature dual-channel discrimination of the 30 MHz pulsed signal.

The first local oscillator is a broad width and low noise frequency synthesizer. The second LO is a fast agile frequency synthesizer developed in our lab [13]. The frequency change is controlled digitally in step of 1 MHz, 100 kHz, and 10 kHz. The change time is within 10 μ s. Thus the automatic frequency control (AFC) is realized.

The quadrature video signals are converted with 12-bit fast A/D to two finite series $e_i(l)$ and $e'_i(l)$ in two adjacent pulses. The convolution of these two signals is expressed as:

$$Y(K) = e_i(l) * e'_i(l) = \sum_{l=0}^K e_i(l) e'_i(K-l)$$

Suppose the pulse is rectangular wave and sampled at the rate of Δt , $Y(K)$ is an ideal triangle whose baseline is $2N-1$ and the peak value appears at $K = N-1$. After normalization:

$$D_I = 2 \sum_{l=1}^{\frac{1}{2}N-1} \cos l \omega \Delta t$$

$$D_Q = -2 \sum_{l=1}^{\frac{1}{2}N-1} \sin l \omega \Delta t$$

Then we can get frequency discrimination curves of D_I , D_Q . The following can be done according to these curves.

- (1) interpulse frequency fluctuation measurement from D_Q feature.
- (2) automatic frequency control to compensate the radio frequency shift.
- (3) measurement of interpulse amplitude and phase fluctuations.

(4) fast spectrum estimation of signal.

2. Quadrature Dual Channel Frequency discrimination

Fig.3 is the basic block diagram of the quadrature dual-channel frequency discrimination system [14]. At first the radio frequency is mixed down to an intermediate frequency, which still remains all the original phase and amplitude information of the transmitters. Then the measurement is made by the IF quadrature dual channel frequency discrimination bridge with a delayer as the frequency discriminator. It can be deduced that the output signals are:

$$A_s(t) = \text{rect}\left(\frac{t}{\tau}\right) \cdot A \sin(\Phi(t) - \Phi(t - \tau_0))$$

$$A_c(t) = \text{rect}\left(\frac{t}{\tau}\right) \cdot A \cos(\Phi(t) - \Phi(t - \tau_0))$$

where: $\text{rect}\left(\frac{t}{\tau}\right) = \begin{cases} 1 & NT < t < NT + \tau \\ 0 & \text{other time} \end{cases} \quad N = 0, 1, 2, \dots$

A: the signal amplitude.

$\Phi(t)$: random phase fluctuation of transmitter signal.

τ_0 : the delay time of IF dlayer

T and τ : repeat period and pulsewidth of the RF pulse.

The average frequency fluctuation in the interval between $t - \tau_0$ and t is:

$$\Delta f = \frac{1}{2\pi\tau_0} \int_{t-\tau_0}^t \Phi'(t) dt = \frac{1}{2\pi\tau_0} [\Phi(t) - \Phi(t - \tau_0)]$$

Combining the Taylor progressions of $\sin\Delta\Phi$, and $\text{tg}\Delta\Phi$, we can express $\Delta\Phi$ and Δf with $A_s(t)$ and $A_c(t)$ as follows:

$$\Delta\Phi = \frac{2}{3} \left[\frac{A_s(t)}{A} + \frac{1}{2} \frac{A_c(t)}{A} \right]$$

$$\Delta f = \frac{A_s(t)}{3\pi\tau_0} \left[\frac{1}{A} + \frac{1}{2A_c(t)} \right]$$

In this case, the nonlinear errors are less than 0.8% in the range $\Delta\Phi \leq 1.8$ rad. Using the mathematical method for data processing, very big frequency fluctuations can be measured. However, only when $\Delta\Phi$ is much smaller than 1 rad, can $\sin\Delta\Phi$ be approximately expressed by $\Delta\Phi$. The transfer function of the system is shown in Fig.4

In short, the quadrature dual-channel frequency discrimination method has the following characteristics.

(1) The system can be operated in a large frequency range and measure the stability of RF pulses with a high sensitivity.

(2) The zero-beat discrimination can be easily realized without the coherent oscillator and the influence of amplitude fluctuation and frequency shift of RF pulses on the measurement can be removed by the system.

(3) With the self-convolution of the system's output signals, we can obtain a function of intrapulse phase fluctuation with the items t , as well as t^2 and t^3 , which are useful for the pulse compressibility radars.

3. Microwave Phase Bridge

The microwave phase bridge is used to measure the additive phase noise of the transmitters with amplifier chains. In our system, the reference signal of the phase bridge is a RF pulse series synchronized with the measured amplifiers. Thus the noise of phase discriminator can be reduced. Low-pass filter is used to filter out the pulse side-band in video signal. Therefore, the sensitivity has been increased in the measurement of phase noise by spectrum analyzer.

The sensitivity in Fourier frequency $f_m = 1\text{kHz}$ is better than -120dB/Hz . The block diagram is shown in Fig.5.

4. Amplitude Measurement

Quadrature dual-channel systems can be used to measure interpulse amplitude fluctuation. The sensitivity is not high, because of the limitation on dynamic range of the video amplifier and A / D converter. The differential amplifier is used to amplify the fluctuation at the pulse tops, the $\Delta A / A$ measurement resolution is up to 0.1% as shown in Fig.6.

5. Time Interval Measurement

The time interval measurement on interpulse timing and pulsewidth is accomplished by a counting unit with analogue interpolation. The resolution in single measurement is 0.1ns with precision of 1ns. The block diagram is shown in Fig.7.

SYSTEM CALIBRATION AND MEASUREMENT RESULTS

1. System Calibration Methods

The measurement system is calibrated with two methods so as to measure the phase and frequency stabilities accurately.

(1) Frequency Modulation Method

The principle of the frequency modulation method is shown in Fig.8. The modulation frequency of the oscillator is doubled and reshaped to drive a PIN pulse modulator. Then we can obtain a RF series whose frequency offset is changed alternately. The system is calibrated with this known frequency offset. And the calibration accuracy is just the same as the oscillator itself.

(2) Phase Modulation Method

Fig.9 is the principle diagram of phase modulator set up with varactor diode used in the microwave phase bridge. The phase modulation linearity is better than ± 1 dB.

2. Measurement Results

Measurements with the system were made on various radar transmitters. We have worked in the experiments on the stability measurements as follow:

(1) The system has been calibrated with the phase or frequency modulation methods.

(2) The types of MTI radar transmitters with magnetron oscillators, whose operation wavelength were 30cm, 10cm and 5cm, pulsewidth is 0.5-10 μ s and repeat frequency is 500Hz-10KHz, were measured with the quadrature dual-channel discrimination system. The system measurement resolution for interpulse frequency stability is 100Hz with accuracy 1kHz. The improvement factor of MTI radar can be measured up to 60 dB.

(3) The phase noise of the transmitters with travelling-wave tube (TWT) amplifiers and the coherent responders at 10cm and 5cm were measured by phase bridge, the sensitivity of which is better than -120dB / Hz.

CONCLUSIONS

As stated above, we have come to the conclusions as follows:

1. The frequency stability of RF pulse series can be characterized with the interpulse variance in time domain, and with the near-carrier phase noise in frequency domain.

2. Quadrature dual-channel frequency and phase discrimination methods are effective for the measurement of interpulse frequency stability.

3. We have made successful measurements with the system designed with the above techniques.

REFERENCES

[1] K.H. Sann, "The Measurement of Near-Carrier Noise in Microwave Amplifiers" IEEE Trans. on MTT, Vol. MTT-16, Sept. 1968 pp 761-766

[2] J.R. Asheley, et al, "The measurement of Oscillator Noise at Microwave frequencies" IEEE Trans. on MTT, Vol. MTT-16, No.9 Sept. 1968. pp753-760

[3] J. G. Ondria, "A Microwave System for Measurement of AM and FM Noise Spectra" IEEE Trans. on MTT, Vol. MTT-16 No.9 sept. 1968 pp 753-760

[4] A. Lance et al, " Phase Noise Measurement in the Frequency Domain" 1977 IEEE-S Interna-

tional Microwave Symposium Digest

- [5] "Optimum Length Transmission Line Discriminator with Low Noise Detector" United States Patent No. 4,002,970 Jan. 11, 1977
- [6] J.R. Asheley et al, "The measurement of Noise in Microwave transmitters" IEEE Trans. on MTT, Vol. MTT-25 No. 4 April 1977 . p294
- [7] John M.Milan " Test set for the measurement of Transmitter Stability Parameters" Proc. 29th Annual Frequency Control Symposium, 1975. pp270-284
- [8] Liu Xiaofan, " The Measurement of Near-Carrier Noise on RF Pulse Series" Journal of Astronautic Metrology and measurement No.3, 1984. pp41-49
- [9] Tang Shensheng, " The Development of a Radar Digital Stability Test Set " Journal of Astronautic Metrology and Measurement, No.3 1988 pp16-24
- [10] M.J. Skonic, " Radar Handbook " Chapter 17, 1970
- [11] J. Rutman, " Characterization of phase and Frequency Instabilities in Precision Frequency Sources: Fifteen Years of Progress " PIEEE 1978, Vol. 66 No.9 Sept. 1978 pp1048-1075
- [12] C.H.Grauling and D.J.Healey, " Intrumentation for Measurement of Short-term Frequency Stability of Microwave Sources " Proc. IEEE. Vol. 54. No.2 Feb . 1966, pp249-257
- [13] Zhou Liren, " A 330 MHz Low Noise Frequency-Agile Synthesizer" Journal of Astronautic Metrology and Measurement, No.1, 1988 pp17-25
- [14] Liu Zhongying, "A New Method for Measuring the Stability of RF Pulse Series " Journal of Astronautic Metrology and Measurement, No.3.1988 pp29-35
- [15] A.L. Gardner and R.S. Hawke, " High Speed Microwave Phase Shifters Varactor Diodes" The Review of Scientific Instruments , No.1, Jan. 1966, pp19-22

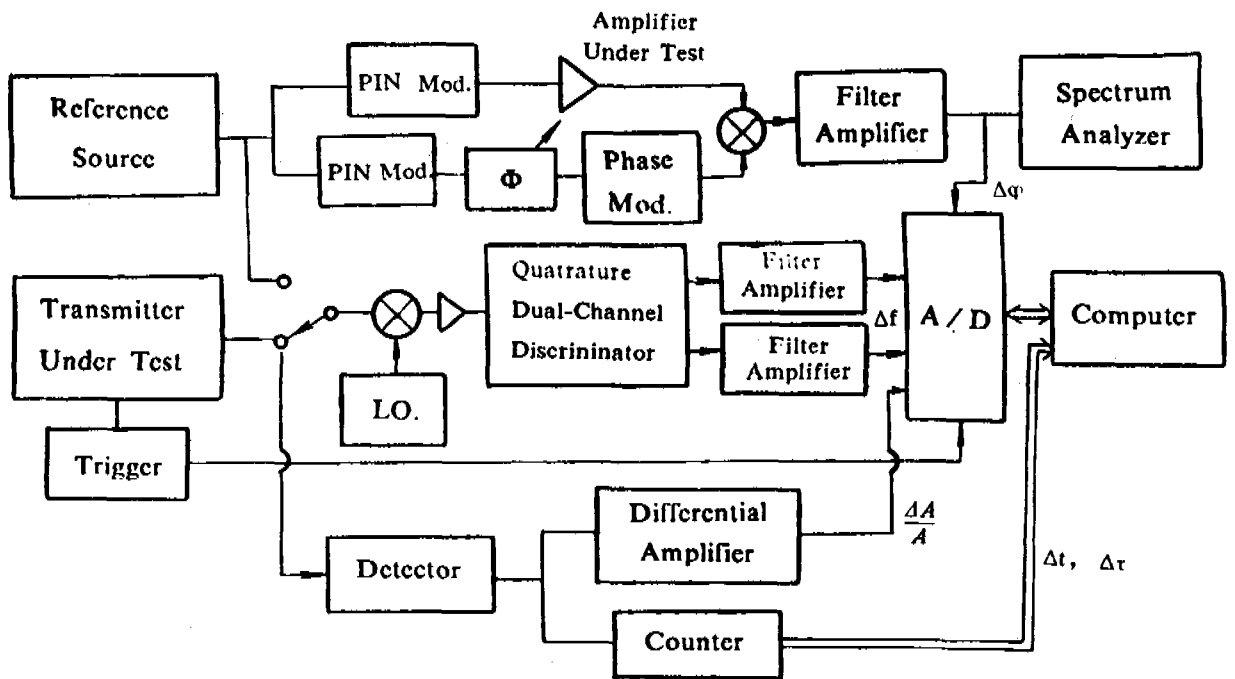

Figure 1. General Measurement System Block Diagram

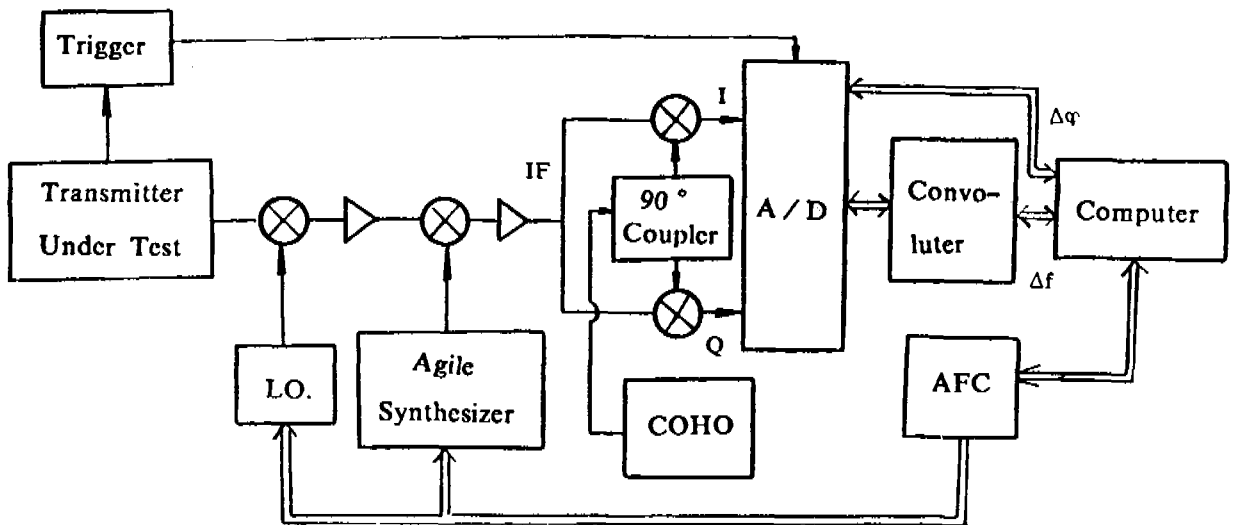

Figure 2. Quatrature Dual Channel Phase Discrimination System Block Diagram

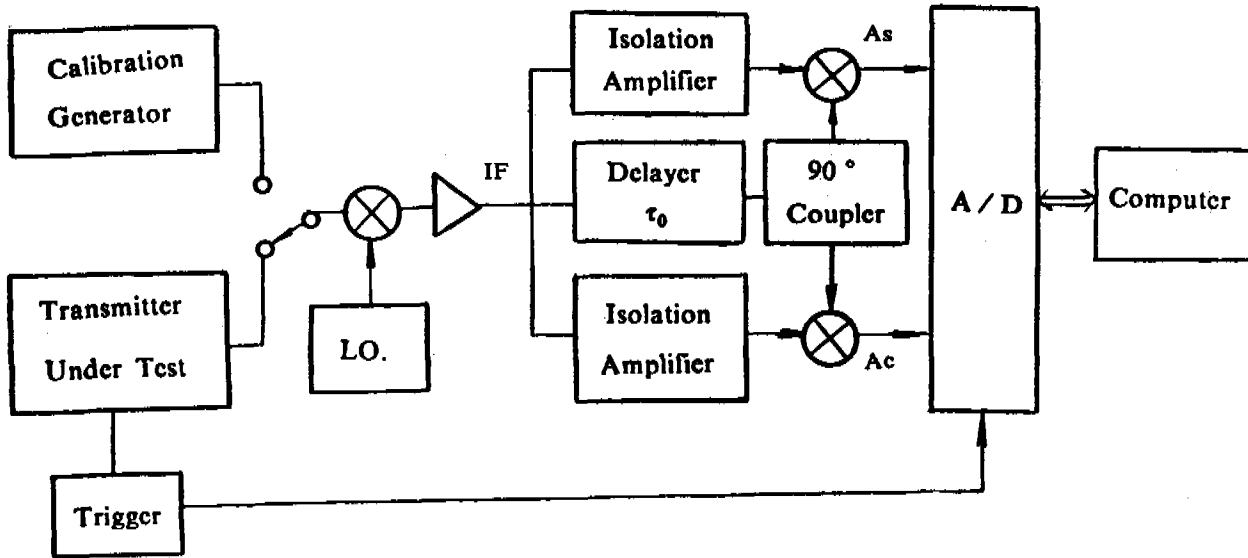

Figure 3. Quadrature Dual Channel Frequency Discrimination System Block Diagram

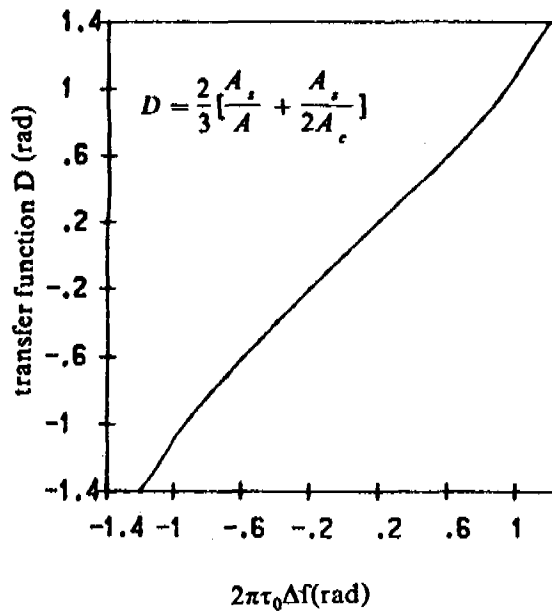

Figure 4. Transfer Function of Frequency Discriminator

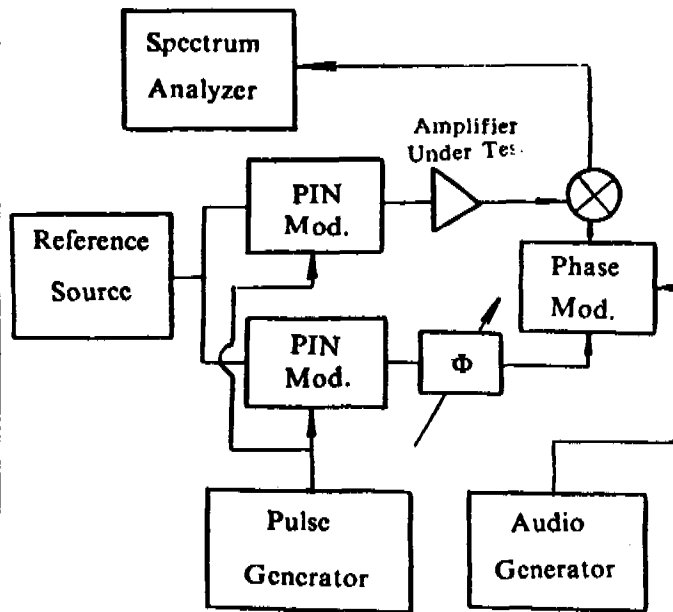

Figure 5. Microwave Phase Bridge Block Diagram

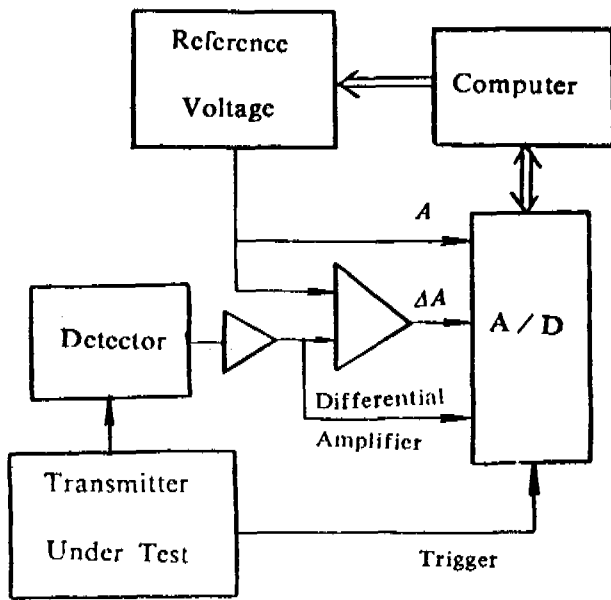

Figure 6. Amplitude Fluctuation Measurement
Block Diagram

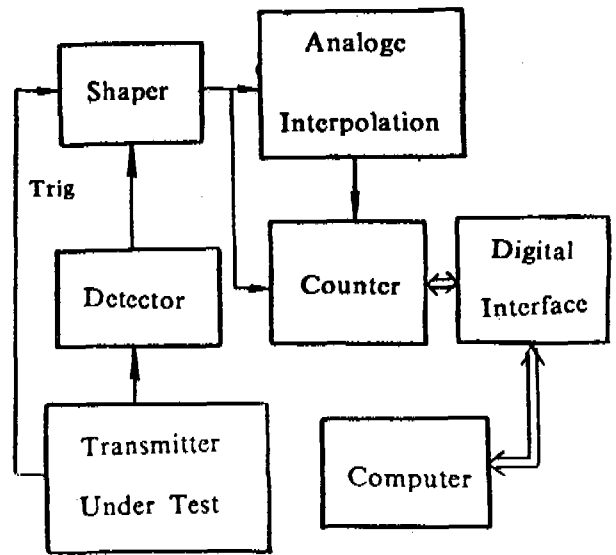

Figure 7. Time Interval Measurement
Block Diagram

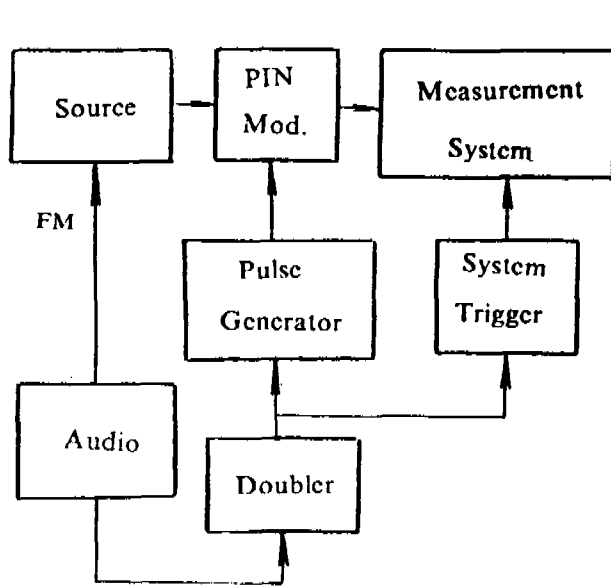

Figure 8. FM Calibration Block Diagram

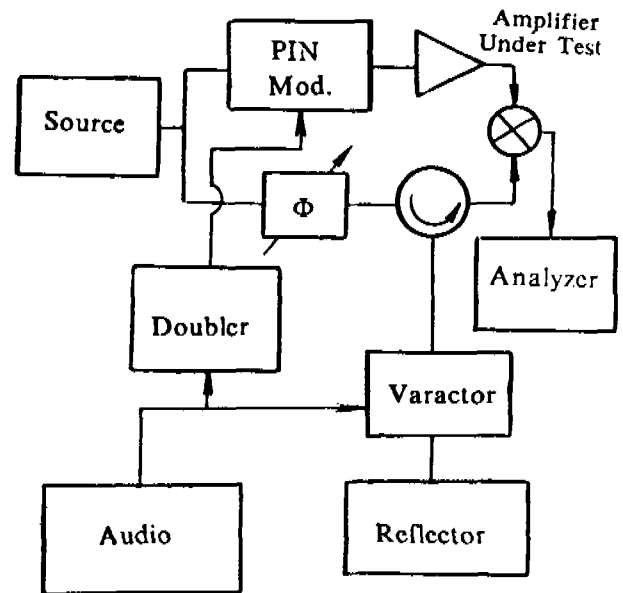

Figure 9. PM Calibration Block Diagram