

USE OF GPS TO SYNCHRONIZE THE AT&T NATIONAL TELECOMMUNICATIONS NETWORK

E. W. Butterline,
AT&T End User Organization,
Network Operations Group

J. E. Abate, G. P. Zampetti,
AT&T Bell Laboratories

Abstract

Presently, AT&T synchronizes its national networks using analog signals derived from a cesium clock ensemble having a precision of a few parts in 10^{-12} . These analog signals have well served the need for precise frequency in what was predominantly an analog network. However, the AT&T network is rapidly being transitioned to a digital network which needs precise time rather than frequency. As a result, several alternatives were considered and the one chosen was a new system based on Global Positioning System (GPS).

The GPS based system, termed a Primary Reference Clock or PRC, employs a GPS receiver providing long term timing accuracy along with duplicated disciplined rubidium oscillators providing short term (ie. one day) stability. Under computer control, these three elements are verified against each other and against identical PRC systems in other parts of the network. The PRC system produces a digital signal used to synchronize a master clock in the node which in turn produces a signal that is (1) used to synchronize all other clocks in the node, and (2) distributed on a digital basis to all neighboring nodes. By use of monitoring equipment at each PRC, the performance of the master clock at every AT&T network node will be verified against the GPS signal at each PRC. For the first time, a national telecommunications network will be monitored and verified to be performing to a precision approaching Universal Coordinated Time (UTC).

INTRODUCTION

Synchronization of telecommunication networks is becoming increasingly important as the evolution of digital switching and transmission facilities becomes the norm in today's national networks. The lack of adequate synchronization for these networks would impair many of the information signals important to the functioning of industry and government. To meet the need for high quality synchronization, AT&T has developed a new verifiable synchronization network.

This paper describes this new synchronization network focusing on the new AT&T Primary Reference Clock (hereafter referred to as the PRC), its verification methodology and capabilities, and the inter-node and intra-node methodology for distributing its timing reference to nodes and systems throughout AT&T's digital and remaining analog networks. The PRC employs a GPS receiver providing long term timing accuracy along with duplicated disciplined rubidium oscillators providing short term (ie. one day) stability. Under computer control, these three elements are verified against each other and against identical PRC systems in other parts of the network. The PRC system produces a digital signal used to synchronize a co-located master clock in the node, which in turn produces a

signal that is: (1) used to synchronize all other clocks in the node, and (2) distributed on a digital basis to all neighboring nodes. By use of monitoring equipment at each PRC location, the performance of the master clocks at neighboring AT&T network nodes are verified against the PRC signal. For the first time, a national telecommunications network is monitored and verified to be performing to a precision approaching Universal Coordinated Time (UTC).

BACKGROUND

Presently, AT&T synchronizes its own national telecommunications network, as well as providing synchronization signals to most of the Regional Bell Operating Companies and many independent telephone companies, using analog signals derived from a cesium clock ensemble [1]. This ensemble, known as the Basic Synchronization Reference Frequency (BSRF) is located in Hillsboro, MO., and has a long term accuracy of a few parts in 10^{-12} . The 2048 KHz reference frequency from the BSRF is distributed on analog radio and coax systems as illustrated in Figure 1.

When BSRF was installed, AT&T used frequency division multiplexing in which even the most critical equipment could tolerate a 10^{-9} frequency offset. This frequency accuracy can be easily obtained from the BSRF distribution system even with transmission impairments such as dropouts, protections switching, and phase hits. The analog signals used to carry the BSRF reference frequency have well served the need for precise frequency in what was predominantly a long haul analog telecommunications network.

Today, however, AT&T is rapidly being transitioned to an all digital network in which time division transmission and switching functions are critical [2]. In general, synchronization of networks using time division systems encompasses bit, frame and network timing issues [3].

The bit timing level of synchronization deals with physical layer timing issues such as: clock insertion and recovery, transmission line jitter, sampling windows in eye patterns, and ones density. These issues are addressed in the fundamental design of the transport system and by adhering to engineering rules such as repeater spacing and maximum number of repeater spans.

The frame timing level of synchronization deals with identifying groupings of bits (time slots) which can be associated with a particular user. A framing signal encoded in the digital transmission system typically accomplishes this function. When time slots within a digital stream need to be processed separately, a frame alignment process is performed on an incoming stream. Once framing is determined, each time slot can be identified and stored for processing. The main synchronization issues at the frame level of synchronization are reframe time and framing loss detection.

The network timing level deals with processing of time slots. Under ideal conditions, time slots are sent from the source node at a perfectly uniform rate, delivered over the transmission system with a fixed delay, and clocked into the receiving node buffer. The receive node will then read the time slot currently in the store after a fixed delay. Assuming no random or systematic offset of the receive node clock relative to the sending clock, this processing will continue with no variation in the buffer and complete time slot integrity.

The objective of network timing, is to approach this idealized scenario. Time slot buffers (more commonly termed frame alignment buffers) can accommodate $125\mu\text{s}$ of systematic time error and $18\mu\text{s}$ of random time error without slipping time slots. The maximum long term systematic frequency departure allowed at the output of a network clock is 1×10^{-11} . This requirement has been established for a number of years both domestically [4,5] and internationally [6,7], and is based on achieving satisfactory slip rates on an end to end basis for the most critical services (voiceband data, facsimile, video, secure voice and secure data). Provisional short term requirements allow from 1 to 10 microseconds of time error in a day at the output of a network clock. The short term requirements are being put in

place to ensure that random or cyclical daily timing variations will not produce daily slips.

The performance objective of 1×10^{-11} for digital network timing is two orders of magnitude greater than the frequency accuracy required for analog transmission. The current synchronization plan to time the digital offices of AT&T was based on using the existing analog distribution system and implementing clocks to receive this signal and achieve the 1×10^{-11} recommendation.

This plan was first implemented in the early 1980's. Analysis of this architecture has been performed. The overall results of this evaluation produced two key findings. First, with evaluation and some minor redesign of the BSRF timing signal receiver algorithms, the 1×10^{-11} performance objective is achievable. Second, the 1×10^{-11} or better objective is subject to certain transmission and operational impairments levels which are not guaranteed to be obtained on all systems at all times based on normal network operations. Thus, although typical performance is several parts in 10^{-12} , it is possible, under certain condition, for a node to degrade to parts in 10^{-10} for a short period.

As a result, AT&T is deploying a network of distributed primary reference clocks to synchronize its digital network. These clocks will use the Global Positioning System (GPS) to provide long term timing accuracy to network nodes or buildings at fourteen locations within the continental United States.

This new synchronization network will have rich interconnectivity and the unique capability of verification at several levels. Verification is the capability to directly monitor the timing performance of each office or node. This capability enables AT&T to detect and resolve timing degradation before it becomes service impacting. Verification ensures uniform compliance of domestic and international timing standards at all nodes, and provides a cost effective tool to sectionalize and resolve timing problems.

AT&T's NEW PRIMARY REFERENCE CLOCK STRATEGY

Figure 2 illustrates the architecture of the new verifiable timing distribution plan. In addition to the fourteen PRC's located in the contiguous United States, PRC's will be located in Hawaii and Puerto Rico. This new synchronization network will have verification capability which permits the detection of timing degradation. The PRC reference is transmitted to other nodes, called secondary nodes, which do not contain a PRC. The PRC simultaneously monitors the reference it receives from at least two other PRC nodes as well as secondary nodes. The monitoring of neighboring PRC locations provides long term stability data. By employing a n-corner hat decomposition [8] of the PRC level stability data, the long term timing stability of each PRC location will be tracked and verified to parts in 10^{-13} . The architecture is designed so that secondary nodes are monitored by two independent PRCs. This provides a means to sectionalize nodal timing instability from transmission path timing instability. By deploying PRC's close to secondary locations, uniformly stable transmission path performance is attained both for transmitting and monitoring performance. Daily transmission path stability should exceed several parts in 10^{-12} .

In searching for a source of precise timing for a PRC, three alternatives were studied. The first was to continue to use a single cesium ensemble at one location along with a digitally based distribution system. The second and third would use regionally distributed PRC's using either LORAN-C or GPS and disciplined timing elements. Using a single cesium ensemble offers some economies, but does not permit nationwide verification, nor does it offer performance improvement over today's network. Using a nodal based system offers a broad based verification capability. LORAN-C was judged inferior to GPS in terms of time transfer accuracy, inherent operations, and future capabilities, so GPS was chosen to provide AT&T with a long term time reference.

Rubidium oscillators were selected over quartz and cesium as the disciplined timing elements. Our

strategy in using the GPS system was based on using a twenty-four hour observation period to obtain a time and frequency error estimate. There are many reasons for this choice. First, a daily ensemble average effectively removes the daily systematic bias errors which arise in the time transfer process of GPS from user position errors and other sources. Second, ensemble averaging of the satellite tracks reduces random error sources as well as intentional degradation added to reduce the accuracy of the standard service. Third, evaluation of ensemble tracks permits the removal of outlying data which can contaminate the steering process.

For periods less than one day, a set of duplicated rubidium oscillators provide timing stability. The stability of the disciplined rubidium over the 24 hour interval between steering updates is equivalent to the stability of the steering update data from the GPS satellite tracks. For a 24 hour steering interval, rubidium oscillators proved to provide the best cost/performance tradeoff. Quartz oscillators cannot obtain the daily stability performance achievable from GPS, and cesium oscillators provide no real stability advantage and are more costly.

An AT&T 3B-2 computer is used to steer the rubidium oscillators and to verify their performance relative to one another and to the GPS receiver. The block diagram given in Figure 3 illustrates the interconnectivity of the PRC's computer, and indicates the DS1¹ inputs from the other nodes and clocks used for timing monitoring. In the figure, the rubidium oscillators (Rb) are shown communicating with the disciplined controllers which in turn communicate with the 3B-2 monitor computer. The computer performs control, performance verification, and error recovery functions.

The timing outputs of the PRC are a pair of DS1 primary rate digital signals. The PRC outputs are used to provide timing reference to a master clock in a node containing typically many clocks. The master clock, known as the Building Integrated Timing Supply, or BITS, provides timing reference to all other clocks in that node as illustrated in Figure 4. The BITS provides input to a device known as a Clock Distribution Unit whose function is to provide multiple DS1 outputs to all clocks in the node requiring digital reference (eg. No. 4 ESS switch, DACS transmission system) and frequency locked clocks for analog frequency division multiplex (FDM) equipment.

INTER-NODE AND INTRA-NODE REFERENCE DISTRIBUTION

Buildings containing a PRC are known as Primary Nodes. Buildings which do not contain a PRC are known as Secondary Nodes and obtain their timing reference from a Primary Node in most cases, or from other Secondary Nodes in rare cases. Timing to Secondary Nodes is distributed on a digital basis using two DS1 signals which are routed over diverse facilities from different PRC's. These DS1 signals carry both traffic and synchronization reference between nodes as illustrated in Figure 5. The reference information is bridged from a cross-connect device known as a DSX-1 and transmitted to the clock of the system selected as the BITS. Thereafter, the reference distribution is the same as in the Primary Node. The timing is embedded in the DS1 traffic carrying signal as that signal is referenced to the BITS clock within the Primary Node which is the source for the reference.

VERIFICATION METHODOLOGY

As illustrated in Figure 6, there are four levels of verification that are used. The first is an ongoing verification of GPS performance by various laboratories such as the National Bureau of Standards,

¹A DS1 is the primary rate synchronous digital signal used in the network. It is a 1544 Kbps signal consisting of 24 64 kbps time slots. Each time slot typically carries a single direction voice circuit.

the Naval Observatory, and the Network Synchronization Laboratory at AT&T Bell Laboratories at Holmdel, NJ. This high level verification results in long term changes in the synchronization network operations such as upgrading of steering algorithms.

The second level of verification is within the PRC itself. The PRC determines the relative timing instability or uncertainty associated with the three clocking elements in the system (the two disciplined rubidium oscillators and the GPS receiver). A three corner hat technique is used to decompose the pair-wise instability measurements between the three components, and determine the timing stability produce by each element. This technique can effectively detect marginal performance in any of the three clocking elements. This technique is limited to detection of short term daily timing instability, since in the long term, rubidium timing is not independent of the GPS receiver.

The third level of verification, called the Primary Tier (or long term) verification uses an N corner hat technique to determine the long term time uncertainty or noise of each of the Primary Nodes (eg. A, B, and C in Figure 6).

Finally, the fourth level, or Secondary Tier Verification, extends verification down to the Secondary Nodes, where the signals returning from the Secondary Node BITS clocks are monitored by at least two PRC's to determine their performance.

PERFORMANCE

Figure 7 illustrates the performance of the AT&T Primary Reference clock as compared to the current AT&T cesium ensemble and telecommunication synchronization standards. In Figure 7, the time keeping error relative to UTC is shown in seconds on the ordinate along with the observation time on the abscissa shown in seconds.

In case (1), the slope of the ANSI and CCITT specification is the allowed long term frequency accuracy of a PRC of 1×10^{-11} . The ANSI and CCITT specifications allow for a maximum daily time instability of 3000 ns which is reflected by the horizontal asymptote.

Case (2) shows typical performance of the AT&T cesium ensemble. It is monitored relative to LORAN-C and found to perform with a long term accuracy within a few parts in 10^{-12} . The daily timing stability is limited by diurnal transmission delay variation of typically 100 ns.

Case (3) shows the time keeping performance of the rubidium disciplined oscillator assuming a failure condition in which no daily steering is applied. It is based on a simplified assumption of optimal calibration of initial time, frequency and drift, and a benign environment. The control system applies feed forward correction for drift and temperature, and the thermal design maintains small ambient temperature variation 5°C daily objective. Monte Carlo simulation of the holdover performance including temperature variation and residual calibration errors have recently been done which indicated that the PRC can maintain 1×10^{-11} for a period of 2 weeks without steering.

Cases (4) and (5) show the PRC performance under normal conditions. Case (4) shows the PRC three sigma time error specification of 200 ns. The PRC three sigma performance bound is based on measurements and analysis of the PRC components and simulation of the Kalman based steering algorithm. Case (5) shows typical performance based on a limited data recently obtained on a prototyped unit. The unit is achieving a daily rms stability of 25 ns (3×10^{-13}).

It is important to note that even though current standards allowed for plesiochronous operation of primary reference clocks, all the PRCs in AT&T will be maintained to within 280 ns (three sigma) of each other with an absolute accuracy approaching UTC (1×10^{-13} weekly rms stability).

CONCLUSIONS

AT&T is deploying a GPS based system, termed a Primary Reference Clock or PRC, which employs a GPS receiver providing long term timing accuracy along with duplicated disciplined rubidium oscillators providing short term (ie. one day) stability. Under computer control, these three elements are verified against each other and against identical PRC systems in other parts of the network. For the first time, a national telecommunications network will be monitored and verified to be performing to a precision approaching UTC.

REFERENCES

- [1] J. F. Oberst, "Keeping Bell System Frequencies on the Beam," Bell System Record, March, 1984
- [2] J. E. Abate, L. H. Brandenburg, J. C. Lawson, W. L. Ross, "No.4 ESS: The Switched Digital Network Plan," Bell System Technical Journal, Vol. 56, No. 7, pp. 1297-1320, Sept. 1977.
- [3] J. E. Abate, J. R. Rosenberger, and M. Yin, "Keeping the Integrated Digital Network in Sync," Bell Laboratories Record, Sept. 1981
- [4] AT&T Technical Reference PUB 60110, "Digital Synchronization Network Plan," December, 1983.
- [5] American National Standard for Telecommunications, "Synchronization Interface Standards for Digital Networks," ANSI T1.101-1987
- [6] CCITT Recommendation G.811, "Timing Requirements at the Output of Primary Reference Clocks Suitable for Plesiochronous Operation of International Digital Links."
- [7] CCITT Recommendation G.824, "The Control of Jitter and Wander Within Digital Networks which are Based on the 1544 kbit/s Hierarchies."
- [8] C. A. Greenhall, "A Likelihood Approach to the M-Cornered Hat-Preliminary Report," Proceedings of PTTI, 1987.

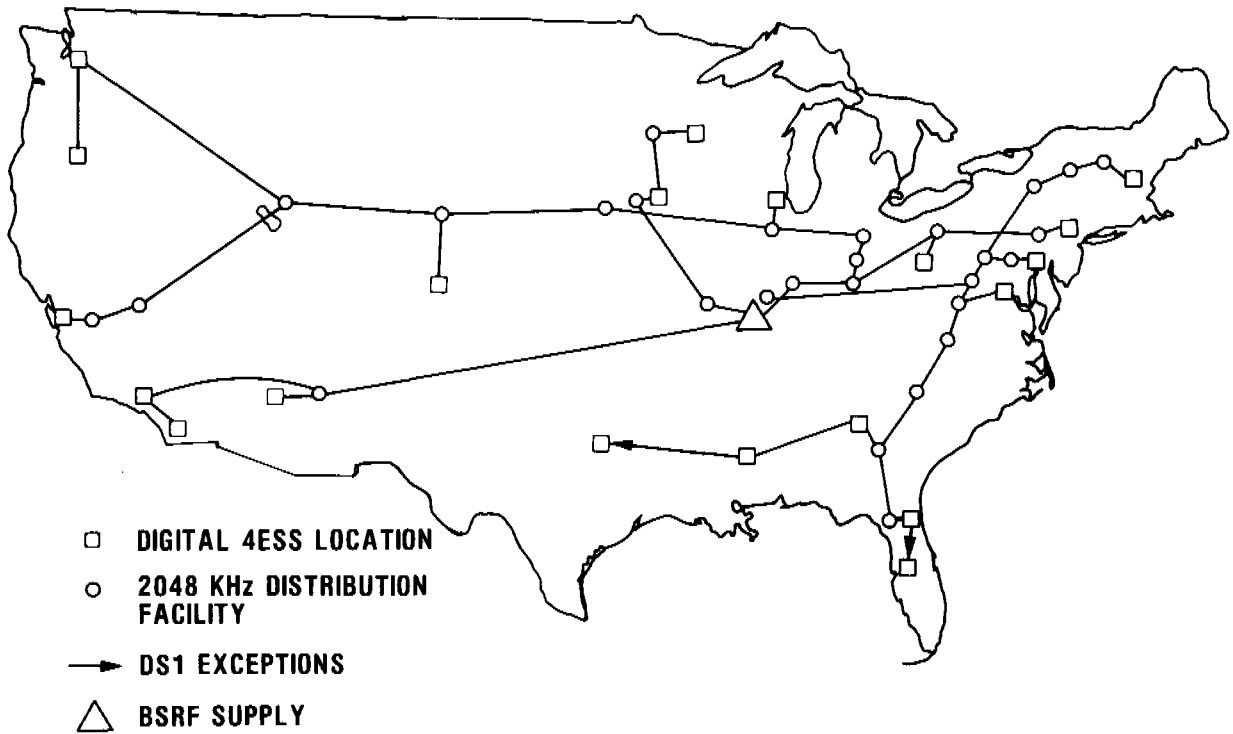

FIG. 1 CURRENT AT&T PRIMARY TIER ANALOG REFERENCE DISTRIBUTION SYSTEM (REPRESENTATIVE)

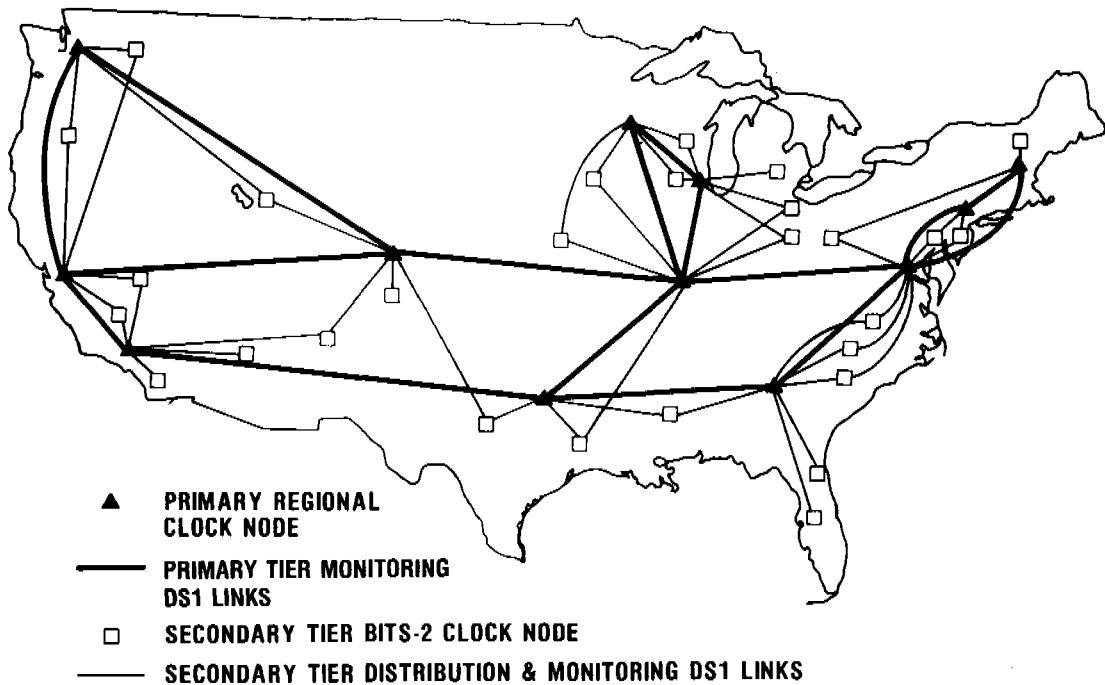

FIG. 2 NEW VERIFIABLE DIGITAL SYNC PLAN (REPRESENTATIVE)

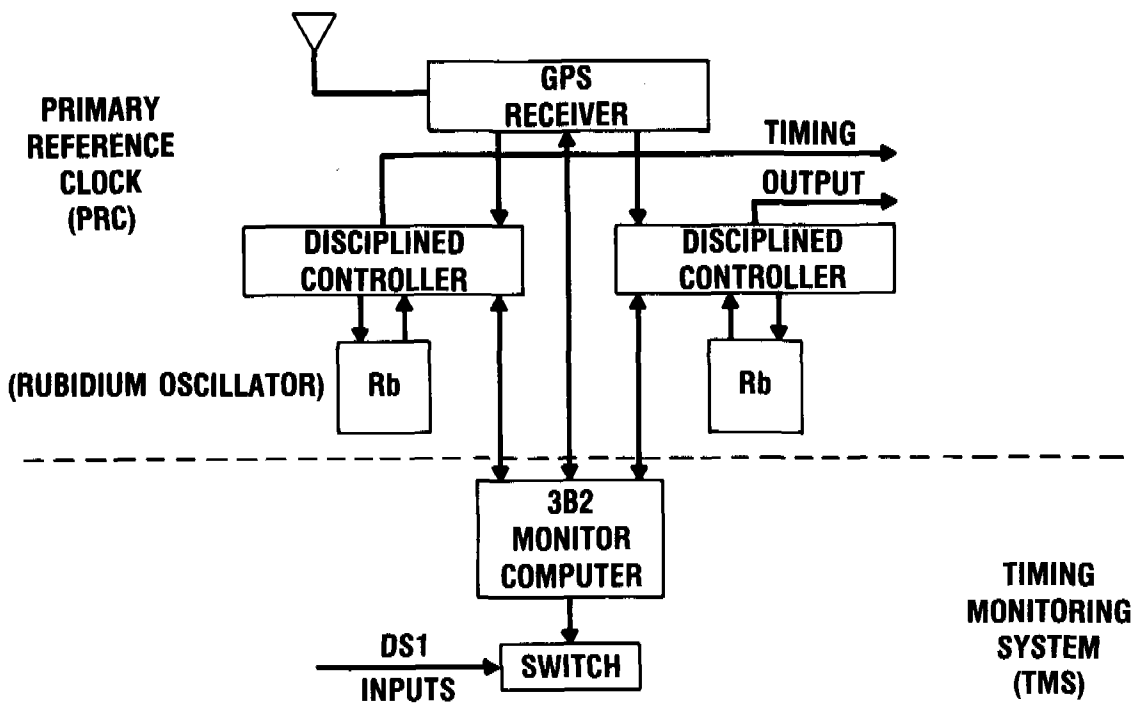

FIG. 3 PRIMARY REFERENCE CLOCK AND TIMING MONITORING SYSTEM

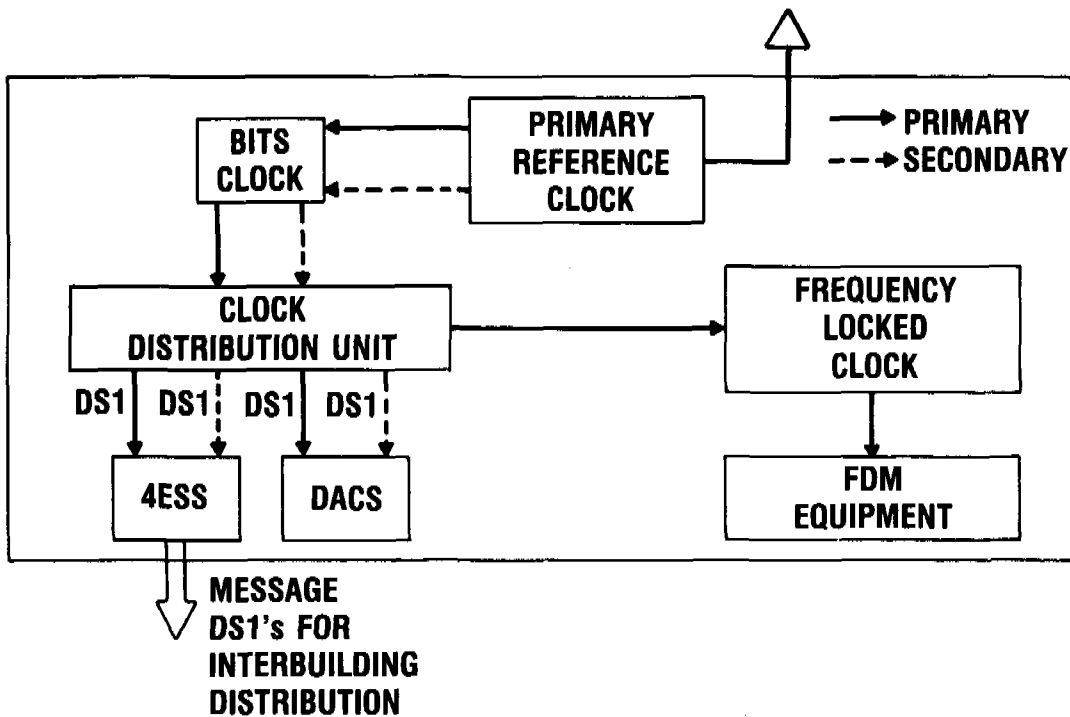

FIG. 4 PRIMARY NODE TIMING DISTRIBUTION

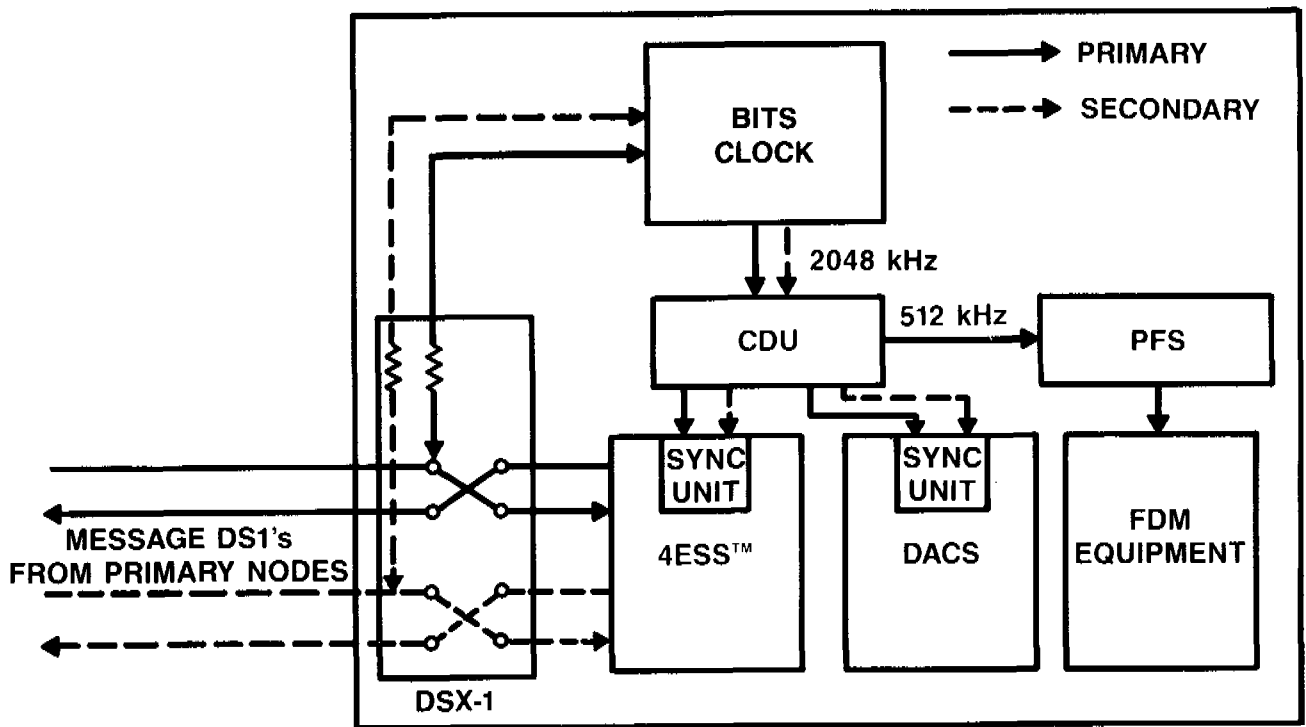

FIG. 5 SECONDARY NODE TIMING DISTRIBUTION

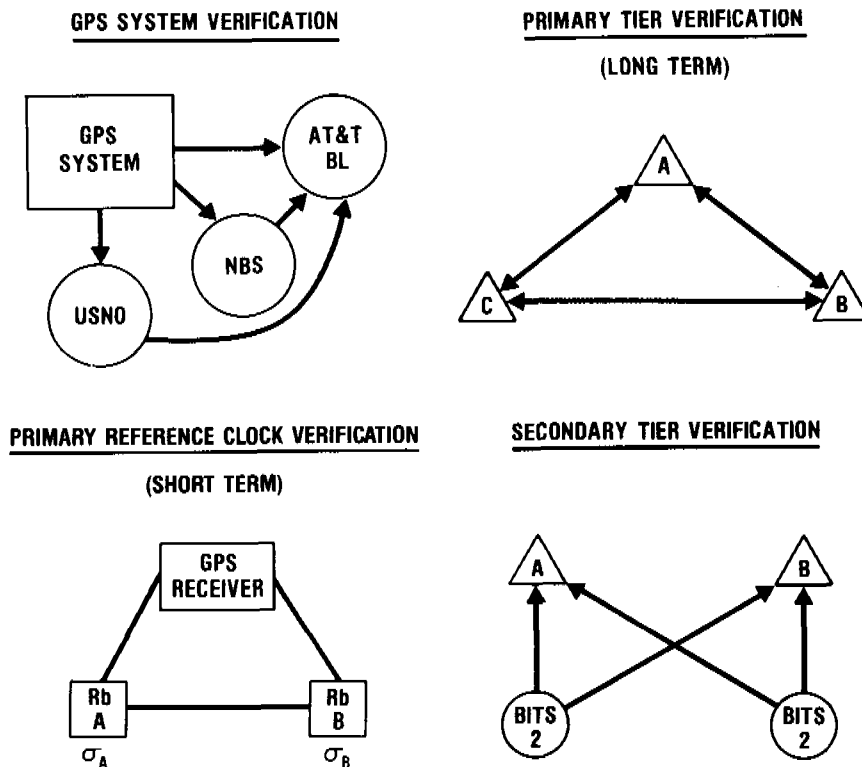

FIG. 6 LEVELS OF VERIFICATION

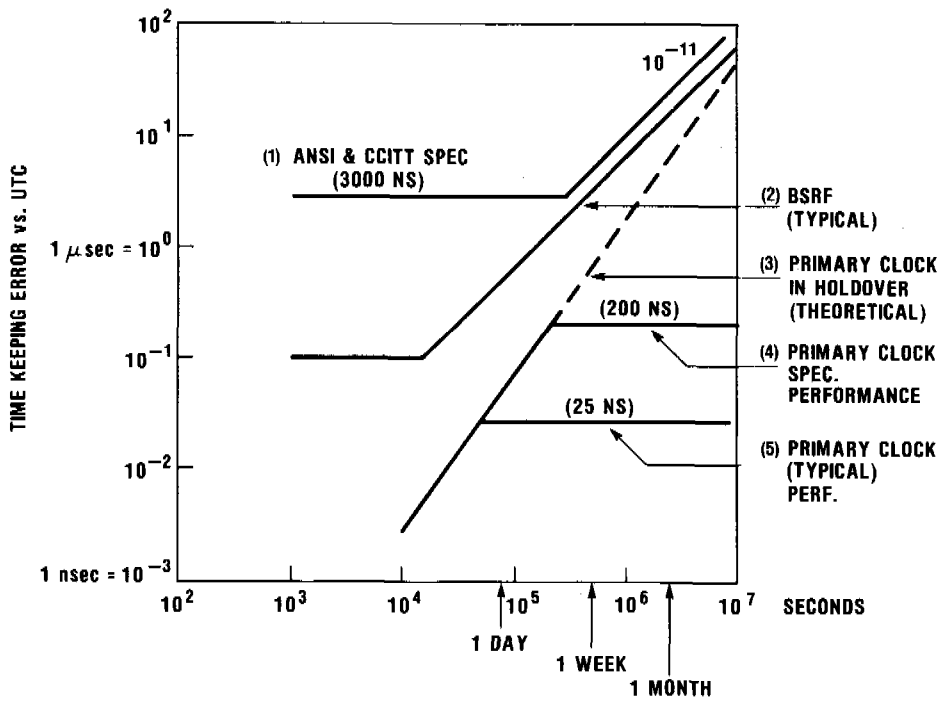

FIG. 7 PERFORMANCE COMPARISONS

QUESTIONS AND ANSWERS

DAVID ALLAN, NIST: Two questions—first, the slope on the red line is not due to a frequency offset since it is steeper than the frequency offset. Is there any explanation as to why it is that steep?

MR. ZAMPETTI: That slope is not due to a frequency offset. It does converge to the frequency offset, and I believe that it is an optimal calibration estimate, assuming random walk FM as a residual. I believe that that slope is plotted correctly as random walk FM. That is a theoretical curve that we just put on for comparison. It shows that the Rubidium is excellent. We have done some simulations incorporating thermal instabilities, calibration errors and other things and have found that for a period of two weeks the system is rock solid and would not require any action. It would still maintain the 10^{-11} stability specification.

MR. ALLAN: The second question is: When you steer the Rubidium, do you use C-field tuning?

MR. ZAMPETTI: Currently, that is what you are using.

MR. ALLAN: If that is not done perfectly, which it never can, of course, then it adds noise to the system. It is an unnecessary noise if one dealt with the measurements instead of trying to tune the C-field.

MR. ZAMPETTI: We are very enthusiastic supporters of synthesis steering. As the system progresses there is the possibility of doing that. It was not available to us as a matter of practical course, but it is something that we are seriously considering.