

REDUNDANT TIME AND FREQUENCY REFERENCE UNITS  
FOR SATELLITE APPLICATIONS

A. Vulcan, C. Gloeckl, M. Meirs, T. McClelland  
Frequency Electronics, Inc.  
Mitchel Field, NY 11553

Abstract

A class of multiple input and output redundant frequency generators is described which provide extremely low noise reference signals to satellite subsystems. The frequency distribution units are designed to survive the hostile environments of space over a ten year mission life. In addition, these systems must maintain frequency accuracies under all conditions and provide for periodic fine frequency tuning adjustments with resolutions of better than  $3 \times 10^{-12}$  in response to external digital tuning commands. To meet these requirements, multiple frequency sources, either quartz, Rubidium, or Cesium are used. Only one of the sources is on line at any given time with a second source powered up in the hot standby mode and additional sources unpowered. Hence, overall emission reliability is maximized and power consumption is reduced. Isolation at the RF outputs between the on-line and the hot standby oscillator exceeds -120 dB. Many of the distribution systems receive DC power from the spacecraft bus and incorporate high efficiency DC/DC converters and low noise linear regulators to provide proper operating voltages for the reference sources and distribution networks. Additionally, a high degree of RFI filtering is included to minimize conducted emissions and susceptibility on the power lines.

## System Description

Figure 1 is a block diagram of a typical satellite frequency generator. The configuration shown is a 3 input, 8 output redundant system. In general, up to N inputs can be used, each feeding a 1 x 2 power splitter whose outputs are recombined in a pair of 1 x N switches. The illustrated generator provides for N frequency sources and 2 individually selectable side amplifiers which are then combined in hybrids. All of the outputs are present regardless of which input source or side amplifier is chosen. The residual noise of the distribution system must be 10 dB below the source phase noise to ensure that negligible L(f) degradation occurs. Other functions which are often part of the frequency generation system are DC/DC converters, telemetry processors, and I/O interfacing circuits which accept various command formats such as relay drive pulses, high noise immunity bipolar commands, or balanced TTL or ECL. These inputs are used for source or side selection and frequency updating. In Figure 1, the operating configuration is set up by energizing the appropriate arm on the 1 x N switches and selecting the desired input. In most applications, the same arm is selected on each switch and the oscillator or frequency source which provides the on-line signal is commanded on internally. One of the other sources can have its oven powered on and the remaining sources can be dormant. There are many configurations which are possible based upon particular mission scenarios.

There are no single point failures in the described frequency generator and the circuitry between the side amplifier and the output is passive to enhance system reliability. Although most often used for 5 MHz reference signal distribution, the described system is also used at frequencies as high as 1 GHz for reference frequency distribution and similar distribution units are used to distribute microwave LO inputs to satellite systems at frequencies up to 20 GHz.

### Performance Characteristics

The requirements for a typical frequency source used in an ultra high stability application are itemized below:

#### Frequency Source Requirements

- \* Low Aging,  $2 \times 10^{-11}$ /Day
- \* Low Phase Noise, dBc/Hz
  - 1 Hz -130
  - 10 Hz -150
  - $10^2$  Hz -155
  - $10^3$  Hz -165
  - $10^4$  Hz -170
- \* Updateable,  $3 \times 10^{-12}$  Resolution
- \* Low G Sensitivity,  $3 \times 10^{-10}$ /G
- \* Hardened
- \* Low Power Consumption

Low aging is, of course, mandatory and the figure shown is for a high stability oscillator; rubidium will be an order of magnitude better. The tabulated phase noise represents current state-of-the-art performance and is at least 15 dB better than what is currently used at Fourier frequencies below 1 KHz. The oscillator can be updateable with the indicated resolution and low G sensitivity, although not required for most space applications, may be important where the system is used through launch to provide communications and telemetry. For certain missions, the system must be hardened.

The frequency distribution portion of the satellite frequency generator performs as follows:

## Frequency Distribution Requirements

\* Low Residual Phase Noise dBc/Hz

1	Hz	-145
10	Hz	-160
$10^2$	Hz	-170
$10^3$	Hz	-175
$10^4$	Hz	-175

\* Low Spurious Signals, -130 dBc

\* High Isolation

Between Inputs, -120 dBc

Between Outputs, -110 dBc

\* Low Temperature Coefficient of Phase,  $2 \times 10^{-14}/^{\circ}\text{C}$

\* Fully Redundant, No Single Point Failures

\* Hardened

Low residual (or additive) phase noise is mandatory and it should be at least 6 dB better than the source. Any spurious signals generated from internal converters or coupled from frequency synthesis chains must be below -130 dBc since most applications require conversion to a microwave frequency and the spurious signals are enhanced by multiplication. In the case of some satellite systems, conversion to 40 GHz by direct synthesis is employed and spurious signals on the 5 MHz reference are enhanced by 78 dB. Isolation between inputs is provided by gating within the oscillator or frequency source, as well as in the 1 x N switch in the frequency distribution subsystem. The isolation must exceed 120 dB to insure that the intermediate and long term stability is not compromised. For most applications, the output isolation is not important although in systems which distribute references to multiple noisy users, 110 dB is necessary to prevent cross-talk. In these cases, additional isolation amplifiers can be placed at the system outputs to achieve this performance with the outputs being redundantly combined at the user end.

Low temperature coefficient of phase is important for certain types of interferometry applications. Modern distribution systems have phase stability of better than  $2 \times 10^{-14}/^{\circ}\text{C}$ . Full redundancy is always designed into the frequency generator with no single point failures. Automatic system reconfiguration based upon subsystem telemetry outputs is normally handled by the satellite computer with software determining the priority. It has been found that automatic hardware switchover can produce non optimum configurations from a reliability standpoint and this chore is left to system software or ground command.

#### Typical System Performance

Table 1 lists the major performance features of eight satellite frequency generators. A comparison of the requirements shows what the design drivers are for the particular missions. Some of the early systems such as FLTSATCOM and LEASAT used redundant quartz oscillators with minimal frequency control capability after launch. In most cases, the long term stability was much better than the projected values due to the benign environment of space and the exponential aging characteristic of the sources. Current all quartz systems are designed to be updated from the ground based upon the measured stability. These oscillators incorporate a high precision reference voltage source and a twelve to sixteen bit D to A converter to supply the analog tuning voltage. All of the frequency determining elements such as the voltage source and D to A converter are ovenized. In cases where a particular tuning voltage must be maintained during a power outage or low voltage condition, the frequency select word is stored in a non-volatile magnetic latching relay array instead of a semiconductor memory. The frequency setting resolution is determined by the number of bits in the memory and the overall adjustment range compensates for aging over the mission lifetime which is typically five to seven years. The temperature coefficient of

PROGRAM	FLTSATCOM	LEASAT	DSP-1	MISSION 34
<u>PARAMETER STABILITY</u> 100 MSEC 1 SEC 10-100 SEC 24 HRS.	3 x 10 <sup>-11</sup> 3 x 10 <sup>-12</sup> 5 x 10 <sup>-12</sup> 1 x 10 <sup>-11</sup>	1 x 10 <sup>-11</sup> 3 x 10 <sup>-12</sup> 5 x 10 <sup>-12</sup> 4 x 10 <sup>-11</sup>	6 x 10 <sup>-12</sup> 2 x 10 <sup>-12</sup> 3 x 10 <sup>-12</sup> 3 x 10 <sup>-11</sup>	5 x 10 <sup>-12</sup> 2 x 10 <sup>-12</sup> 3 x 10 <sup>-12</sup> 2 x 10 <sup>-11</sup>
FREQUENCY ADJUSTMENT RANGE	MANUAL 3 x 10 <sup>-7</sup>	MANUAL 3 x 10 <sup>-7</sup>	REMOTE 2.5 x 10 <sup>-7</sup>	REMOTE 2.5 x 10 <sup>-7</sup>
TEMPERATURE COEFFICIENT	4 x 10 <sup>-11</sup> /25°C	1 x 10 <sup>-10</sup> /50°C	3 x 10 <sup>-11</sup> /15°C	3 x 10 <sup>-11</sup> /15°C
DC POWER AT 25°C	2.3 WATTS	2.3 WATTS	2.2 WATTS	2.2 WATTS

PROGRAM	DSCS III	FLT Rb	DORIS	INTEL VI
<u>PARAMETER STABILITY</u> 100 MSEC 1 SEC 10-100 SEC 24 HRS.	3 x 10 <sup>-11</sup> 3 x 10 <sup>-12</sup> 5 x 10 <sup>-12</sup> 2 x 10 <sup>-11</sup>	5 x 10 <sup>-11</sup> 5 x 10 <sup>-12</sup> 3 x 10 <sup>-11</sup> 1 x 10 <sup>-10</sup>	6 x 10 <sup>-12</sup> 2 x 10 <sup>-12</sup> 5 x 10 <sup>-13</sup> 3 x 10 <sup>-11</sup>	5 x 10 <sup>-12</sup> 2 x 10 <sup>-12</sup> 3 x 10 <sup>-12</sup> 2 x 10 <sup>-11</sup>
FREQUENCY ADJUSTMENT RANGE	REMOTE 3 x 10 <sup>-7</sup>	REMOTE 1 x 10 <sup>-6</sup>	MANUAL 2.5 x 10 <sup>-7</sup>	REMOTE 3.2 x 10 <sup>-7</sup>
TEMPERATURE COEFFICIENT	4 x 10 <sup>-11</sup> /25°C	1 x 10 <sup>-10</sup> /25°C	3 x 10 <sup>-11</sup> /15°C	3 x 10 <sup>-11</sup> /15°C
DC POWER AT 25°C	2.3 WATTS	1.5 WATTS	2.2 WATTS	2.5 WATTS

TABLE 1  
SATELLITE FREQUENCY SOURCE REQUIREMENTS

frequency must be small enough so as to not add a significant frequency offset over the temperature ranges shown. For example, the FLTSATCOM oscillator exhibits a  $4 \times 10^{-11}$  change for a 25°C change in temperature. Normal thermal excursions range from 5°C to 10°C.

Figure 2 shows the configuration of a typical triple redundant distribution unit. In this particular application, the three master oscillators are mounted directly on the distribution unit to increase reliability and eliminate interconnecting cables. The packaging concept is typical of most satellite frequency generators with a filter and power conditioning compartment accepting power, command and telemetry signals.

#### Conclusion

The design criteria for present day satellite frequency distribution subsystems is discussed. The important characteristics of frequency sources used in several satellites are itemized and a typical mechanical design is illustrated. As the mission goals of newer programs become more sophisticated, frequency stability, phase noise, and system reliability must all be improved to meet the new requirements.

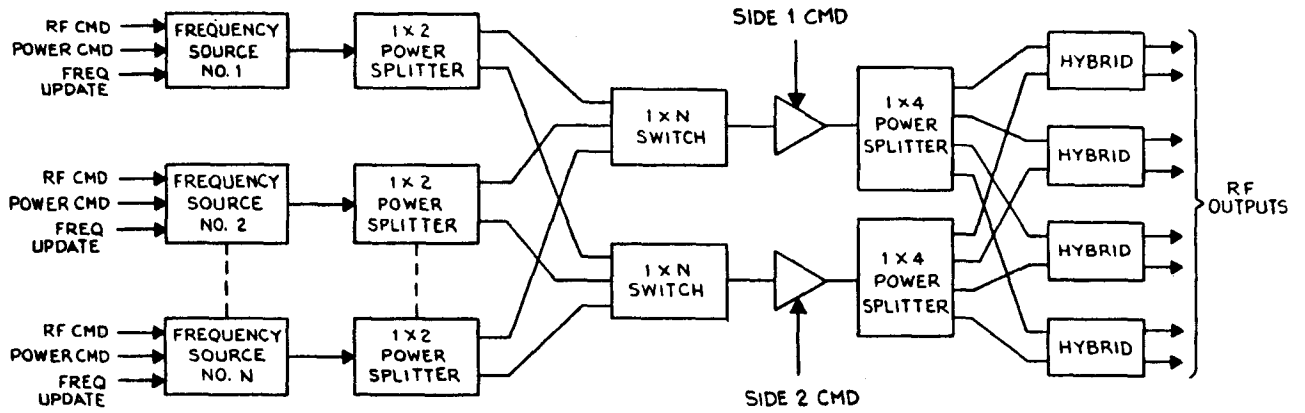

FIGURE 1  
 GENERALIZED BLOCK DIAGRAM  
 N X 8 REDUNDANT FREQUENCY GENERATOR

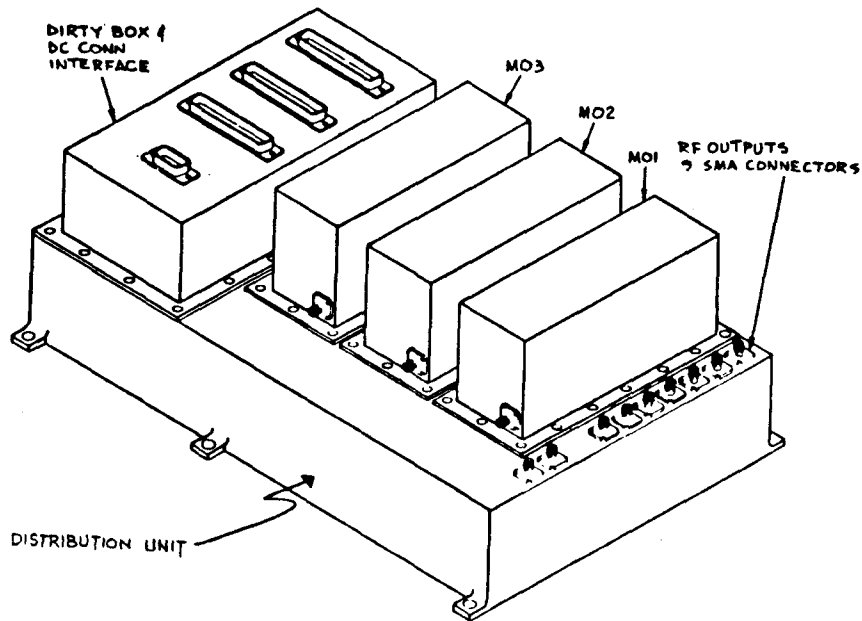

FIGURE 2  
 TRIPLY REDUNDANT DISTRIBUTION UNIT