

THE JPL TRAPPED ION FREQUENCY STANDARD DEVELOPMENT*

J. D. Prestage, G. J. Dick, L. Maleki
California Institute of Technology
Jet Propulsion Laboratory
4800 Oak Grove Drive
Pasadena, California 91109

ABSTRACT

Mercury 199 Ions are confined in an RF trap and state-selected by use of optical pumping with 194 nm UV light from a ^{202}Hg discharge lamp. Absorption of microwave radiation at the hyperfine frequency (40.5 GHz) is signaled by atomic fluorescence of the UV light. The frequency of a 40.5 GHz oscillator is locked to a 1.6 Hz wide atomic absorption line of the trapped ions. The measured Allan variance of this locked oscillator is currently $\sigma_y(\tau) = 4.4 \times 10^{-12}/\sqrt{\tau}$ for $20 < \tau < 320$ seconds, indicating better short term stability than the best commercial cesium standards by almost a factor of two. This first result was achieved without magnetic shielding and without regulation of ion number.

I. Introduction

There has been much recent activity directed toward the development of trapped ion frequency standards, in part because ions confined in an RF quadrupole trap are subjected to very small perturbations of their atomic energy levels. Such small perturbations can lead to accurate frequency standards. Once state selection has been carried out, ions can remain in a single atomic level for many seconds since the forces which restore thermal distributions in atomic level populations are weak in the high vacuum trapping environment. This can permit interrogation times of a few seconds and hence, sub-hertz resonance linewidths.

Potentially, the largest source of frequency fluctuation for such standards stems from the motion of the atoms within the trap via the second order Doppler or relativistic time dilation effect. To minimize this perturbation, heavy ions are preferable to light ions since for a given kinetic energy a heavy ion will have a smaller velocity. For this and other reasons discussed later in this paper, Hg^+ ions have been used for most trapped ion frequency standard work.

Only two parameters are needed to describe the short-term stability of an atomic frequency standard. One is the line Q ($= f/\Delta f$) where f is the resonant frequency of the reference atom and Δf is the width of the atomic resonance. For $^{199}\text{Hg}^+$, f is 40.5 GHz and Δf may be as small as 0.1Hz, thus trapped ion standards can have line Q's which are more than an order of magnitude higher than other microwave atomic frequency standards.

The other parameter that determines stability is the signal-to-noise ratio (SNR) achieved in measuring the atomic resonance. The short-term stability is inversely proportional to the product of Q and SNR. At present, four groups worldwide are developing trapped Hg^+ ion clocks: Hewlett-Packard, Palo Alto, Ca.^[1]; National Bureau of Standards, Boulder, Co.^[2]; Université Paris-Sud, Orsay, France^[3]; and JPL. Our goal at JPL is the development of a trapped ion standard with stability of 10^{-15} at 1000 seconds. A longer term goal is to achieve frequency stability in the 10^{-17} range. It should be noted that F.G. Major first proposed the use of trapped $^{199}\text{Hg}^+$ ions as a frequency standard while working for NASA

* The research described in this paper was carried out by the Jet Propulsion Laboratory, California Institute of Technology, under a contract with the National Aeronautics and Space Administration

at the Goddard Space Flight Center in 1969^[4].

II. Ion Trapping

The electrode structure and time-varying voltages used to trap ions are shown in Figure 1. The electric potential inside the trap when no ions are present is taken to be that of ideal hyperbolic electrode surfaces (no holes, no truncation of the electrode surface)

$$V_T = \frac{U_o + V_o \cos \Omega t}{\epsilon^2} (r^2 - 2z^2)$$

where, for the present work,

$$\begin{aligned} \Omega &= (2\pi) 500 \text{kHz}, \\ U_o &= 20V, \\ V_o &= 660V, \\ \epsilon^2 &= (r_o^2 + 2z_o^2), \text{ and} \\ r_o &= \text{inside radius of ring electrode} \\ &= 1.9\text{cm} = \sqrt{2}z_o. \end{aligned}$$

A charged particle moving in the inhomogeneous oscillatory electric field of the ion trap feels a net force (averaged over one cycle of Ω) toward the region of weaker field provided the amplitude of its motion at frequency Ω is small compared with its distance from the center of the trap. The motion under these conditions is a combination of a fast oscillation at frequency Ω (micromotion) and a slower frequency ω , as shown in Figure 2. The action of the RF field in trapping ions is described by the electric pseudopotential energy^[5],

$$\Psi = \frac{e^2 V_o^2 (r^2 + 4z^2)}{m \Omega^2 \epsilon^4}$$

where m and e are the ion's mass and charge, respectively. The DC potential energy,

$$\Phi_{DC} = eU_o(r^2 - 2z^2)/\epsilon^2$$

is added to the pseudopotential giving the total potential energy for an ion in the trap,

$$\Phi_T = m\omega_r^2 r^2/2 + m\omega_z^2 z^2/2$$

where:

$$\begin{aligned} \omega_r^2 &= \frac{2e^2 V_o^2}{m^2 \Omega^2 \epsilon^4} + \frac{2eU_o}{m\epsilon^2} \\ \omega_z^2 &= \frac{8e^2 V_o^2}{m^2 \Omega^2 \epsilon^4} - \frac{4eU_o}{m\epsilon^2} \end{aligned}$$

Under the conditions listed earlier ≈ 19 electron volts of kinetic energy is required for an $^{199}\text{Hg}^+$ ion at the trap center to reach one of the trapping electrodes.

Our trap is inside a vacuum chamber with pressure $\approx 1-2 \times 10^{-8}$ torr. By heating a powder of isotopically enriched mercuric oxide (HgO) to about 100°C , a vapor of neutral ^{199}Hg fills the vacuum chamber to about 10^{-8} torr partial pressure. Electrons from a LaB_6 single crystal filament are injected into the trap ($\approx 30 \mu\text{A}$, 200V) ionizing some of the neutral Hg inside the trap electrode structure.

The resulting ion cloud is much hotter than the room temperature neutral vapor partially because ionization of the vapor takes place throughout the trap. It has been found experimentally that the average kinetic energy of the ions is about 10% of the well depth^[6]. The resulting 2eV of kinetic energy would produce a fractional second order Doppler shift of about 10^{-11} . To reduce this shift the vacuum system is filled to about 10^{-5} torr of ^4He . The Hg^+ ions collide with these room temperature He atoms and are cooled to near room temperature.

III. Magnetic Levels and State Selection

The magnetic structure of the ground state hyperfine levels of $^{199}\text{Hg}^+$ is shown in Figure 3. The energy difference between the $(F = 0, m_F = 0)$ and $(F = 1, m_F = 0)$ levels is used to define the standard frequency, approximately $f_{\text{Hg}^+} = 40.507347997$ GHz. The measured frequency, f , depends quadratically on the magnetic field at the position of the ion cloud, $f = f_{\text{Hg}^+} + 97B^2(\text{Hz}/\text{G}^2)$. For comparison, the field dependence for Hydrogen atoms is $f = f_H + 2750B^2(\text{Hz}/\text{G}^2)$.

The ions are state selected by use of optical pumping with light from a ^{202}Hg discharge lamp. The energy levels of $^{199}\text{Hg}^+$ and $^{202}\text{Hg}^+$ are compared in Figure 4. Ultraviolet light of wavelength 194 nm (≈ 6.4 eV) from the ^{202}Hg lamp, when collected and focused onto the $^{199}\text{Hg}^+$ ions will excite the transition $^2\text{S}_{1/2} (F = 1, m_F) \rightarrow ^2\text{P}_{1/2}$.

The $^2\text{P}_{1/2}$ state decays after 2 ns lifetime to either $^2\text{S}_{1/2} (F = 0, m_F = 0)$, or the $^2\text{S}_{1/2} (F = 1, m_F)$ emitting a 194 nm photon. Since the transition $^2\text{S}_{1/2} (F = 0, m_F = 0) \rightarrow ^2\text{P}_{1/2}$ is not resonant with the light from the ^{202}Hg lamp, the ions are pumped out of the $^2\text{S}_{1/2} (F = 1, m_F)$ state into the $^2\text{S}_{1/2} (F = 0, m_F = 0)$ state at which time they stop scattering UV light. A flux of about 3×10^{12} photons per second per cm^2 passing through the ion cloud will depopulate the $^2\text{S}_{1/2} (F = 1, m_F)$ levels in about 1/2 second. An oscillating magnetic field (strength 10^{-6} G) at frequency 40.507347997 GHz will transfer the atoms from the $^2\text{S}_{1/2} (F = 0, m_F = 0)$ state to the $^2\text{S}_{1/2} (F = 1, m_F = 0)$ state in about 1 second. The ions will then scatter UV light until they are pumped back into the non-fluorescing $^2\text{S}_{1/2} (F = 0, m_F = 0)$ state.

III. UV Optical System

Figure 5 shows the optical system used to collect and focus UV light from the ^{202}Hg lamp onto the ion cloud. The lamp is excited with 15-20 watts of rf power (160 MHz) creating a very bright discharge in the quartz cell containing the ^{202}Hg vapor with about 30 millitorr of argon buffer gas. The useful light from the ^{202}Hg lamp is from the 194 nm transition in $^{202}\text{Hg}^+$ shown in Figure 4.

However, the brightest wavelengths produced in the lamp are from transitions in the neutral Hg atom. Any light detected at wavelengths other than 194 nm will degrade the SNR of the measured atomic resonance. There are three ways we suppress the detection of light with wavelength different from 194 nm:

- 1) The photomultiplier tube (PMT) is only sensitive to light that has wavelength between 160 and 320 nm with peak sensitivity of 12-15% at 210 nm. The brightest line coming from the lamp in this bandwidth is 254 nm and is 200 times brighter than the 194 nm line.
- 2) The ellipsoidal collection mirror has a thin film dielectric coating which maximizes reflection at 194 nm while keeping the reflectivity at 254 nm at 10%, with still lower reflectivities for longer wavelengths. The entrance window to the trap region is coated to reflect 98% at 254 nm while transmitting 90% at 194nm.

- 3) All light collected by the detection optics—stray scattered light plus fluorescent light from the atoms—is filtered with a 194 nm bandpass filter with peak transmission 30-40% and bandwidth 45 nm.

In the present measurement the solid angle subtended by the collection optics around the trap center is 5% of the total 4π solid angle. The total collection efficiency of this detection system is equal to the solid angle times the bandpass filter loss times the PMT sensitivity or, $0.05 \times 0.35 \times 0.12 = 2 \times 10^{-3}$.

The atomic fluorescence and stray scattered light can be seen in Figure 6. The horizontal sweep is triggered by the start of a pulse of electrons from the filament which forms some ions and causes some increase in detected light. After about 1 second the electron pulse is switched off, the ions are optically pumped into the $^2S_{1/2}$ ($F = 0, m_F = 0$) level and only stray light is collected. At 2 seconds, the 40.5 GHz radiation is switched on transferring some of the atoms into the $^2S_{1/2}$ ($F = 1, m_F = 0$) state where they scatter light as discussed earlier. Finally, at about 3 seconds, the microwaves are switched off and the atomic fluorescence dies away in about 1/5 second.

By monitoring the decay of fluorescence while the microwave radiation is continuously applied we have measured the trapping time for $^{199}\text{Hg}^+$ ions (time until fluorescence is reduced by $1/e$) to be about 150 seconds at 10^{-5} torr helium pressure.

The collected light measured against time in Figure 7 is another useful diagnostic. For the first second electrons are pulsed through the trap to load ions. After 1/2 second of optical pumping the lamp is switched off as the microwaves are being switched on. During this "dark" period the populations of the ($F=0, m_F=0$) and ($F=1, m_F=0$) states are equalized. When the lamp is switched on again the ions fluoresce as they are re-pumped into the non-fluorescing ($F=0, m_F=0$) level. This cycle is then repeated except that during the second dark period no microwave radiation is applied. The fluorescence following this dark period is a measure of the free relaxation from the ($F=0, m_F=0$) level to the ($F=0, m_F$) levels due primarily to charge transfer from a neutral ^{199}Hg atom to a polarized $^{199}\text{Hg}^+$ ion. In this way a polarized ion is replaced by one which is unpolarized.

IV. Closed Loop Operation

The sequence of operations used to carry out a measurement of the $^2S_{1/2}$ ($F=0, m_F=0$) \rightarrow $^2S_{1/2}$ ($F = 1, m_F = 0$) frequency is shown in Figure 8. By repeating this sequence as the frequency of the microwaves is stepped in 0.2 Hz increments, we measure the resonance curve shown in Figure 9. For the 0.5 second square microwave pulse used in this measurement, the smallest linewidth theoretically attainable is 1.6 Hz, which corresponds to $Q = 2.5 \times 10^{10}$.

Locking the 40.5 GHz oscillator to the 1.6 Hz wide resonance line is done by stepping the oscillator 0.8 Hz to either side of the resonance and adjusting the center frequency of this + 0.8 Hz step to null the difference in fluorescence rates. More precisely, suppose the center frequency of the 40.5 GHz oscillator, F_i is within one linewidth of the resonance. Three measurements of the fluorescence are made on alternate sides of F_i :

$$C_1 \text{ at } F_i + 0.8\text{Hz}$$

$$C_2 \text{ at } F_i - 0.8\text{Hz}$$

$$C_3 \text{ at } F_i + 0.8\text{Hz}$$

The oscillator center frequency is then changed to:

$$F_{i+1} = F_i + (0.8\text{Hz}/T)(C_1 + C_3 - 2(C_2))/[2(\text{SIGNAL})]$$

where SIGNAL is the height of the fluorescence above background and T is the loop time constant in units of measurement cycle time. The "second difference" $[C_1 + C_3 - 2(C_2)]$ is used because it is insensitive to linear drifts in lamp intensity^[1,7]. If the first difference $(C_1 - C_2)$ had been used to change F_i , a linear drift in lamp intensity would force a linear drift in the 40.5 GHz oscillator's frequency, away from the atomic line center.

The sequence of center frequencies obtained in this closed loop operation is shown in Figure 10. The measurement shown lasted just over 2 hours. A single measurement cycle—electron pulse to load ions in the trap, a wait period while ions are optically pumped, lamp off while microwaves drive the transition, and lamp on and counter on to monitor fluorescence—lasts about 2.5 seconds. The loop time constant, T, is 5 measurement cycles, that is, about 12.5 seconds.

The Allan variance derived from the sequence of frequencies F_i is shown in Figure 11. The reference frequency for the 40.5 GHz oscillator is provided by a Hydrogen Maser (SAO-21 in the Frequency Standards Laboratory). For times long compared to the loop time constant the Allan variance falls as $4.4 \times 10^{-12}/\sqrt{\tau}$. This short-term stability is nearly a factor of 2 better than that of the best commercial Cesium standards ($8.5 \times 10^{-12}/\sqrt{\tau}$). These first results were done without shielding the 0.8 G ambient magnetic field in the trap. The residual field dependence at 0.8 G is 157 Hz/G. Frequency stability of 2×10^{-13} at this field sensitivity requires magnetic field fluctuations smaller than 60 μ G over the 320 seconds required to reduce statistical error to 2×10^{-13} . For this reason we have not measured the Allan variance data beyond 320 seconds in this first test.

IV. Improved Optical System

Since achieving this closed loop operation we have designed and installed a new lens system which increases the fluorescence collection solid angle of the previous system by a factor of three. We have repeated the measurement of Figure 6 to test the light gathering power of the new system and the results are shown in Figure 12. The measurement of Figure 12 took one half the time of that of Figure 6. A comparison of these two figures shows an increase of just over three in light collected with the new system. We have not yet repeated the closed loop operation with this new system.

V. Conclusion and Summary

In its first closed loop operation, the frequency stability of the trapped $^{199}\text{Hg}^+$ frequency standard has been measured to be

$$\sigma_y(\tau) = 4.4 \times 10^{-12}/\sqrt{\tau} \text{ for } 20 < \tau < 320 \text{ seconds.}$$

Many improvements are underway to increase the short- and long-term stability of this standard including design and construction of a non-magnetic ultra-high vacuum system, shielding the ambient magnetic field, and designs for traps which could store up to a hundred times the present ion number with no increase in 2nd order Doppler shift.

ACKNOWLEDGEMENTS

We wish to thank T. Tucker for Hg lamp construction and assisting in the development of the 40.5 GHz oscillator.

REFERENCES

1. Cutler, L. S., R. P. Giffard, and M. D. McGuire, "A Trapped Mercury 199 Ion Frequency Standard," Proc. 13th Ann. PTTI Meeting (1981), NASA Conf. Publ. 2220, p. 563.
2. Wineland, D. J., Itano, W. M., Bergquist, J. C., and Walls, F. L., "Proposed Stored $^{201}\text{Hg}^+$ Ion Frequency Standards," Proc. 35th Ann. Sym. on Freq. Control, Philadelphia, Pa., p. 602.
3. Jardino, M., Desaint-Fuscien, M., and Plumelle, F., "Prospects for a Mercury Ion Frequency Standard," Journal de Physique, C8 (1981), p.327.
4. Major, F. G., "Remarks on the Application of RF Spectroscopy of Stored Ions to Frequency Standards," FAA Util. of Time/Freq. in Collision Avoidance Systems, N69-19856 09-14 (1968), p. 125-126.
5. Dehmelt, H. G., "Radio Frequency Spectroscopy of Stored Ions," Adv. At. Mol. Phys. 3, (1967), p. 53-154.
6. Ifflander, R., and Werth, G., "Optical Detection of Ions Confined in a RF Quadrupole Trap," Metrologia 13 (1977), p. 167-170.
7. Jardino, M., Desaintfusien, S., Barillet, R., Viennet, J., Petit, P., Audoin, C., "Mercury Ion Frequency Standard : Preliminary Results," Proc. 34th Ann. Freq. Control Symposium (1980), p. 353-359.

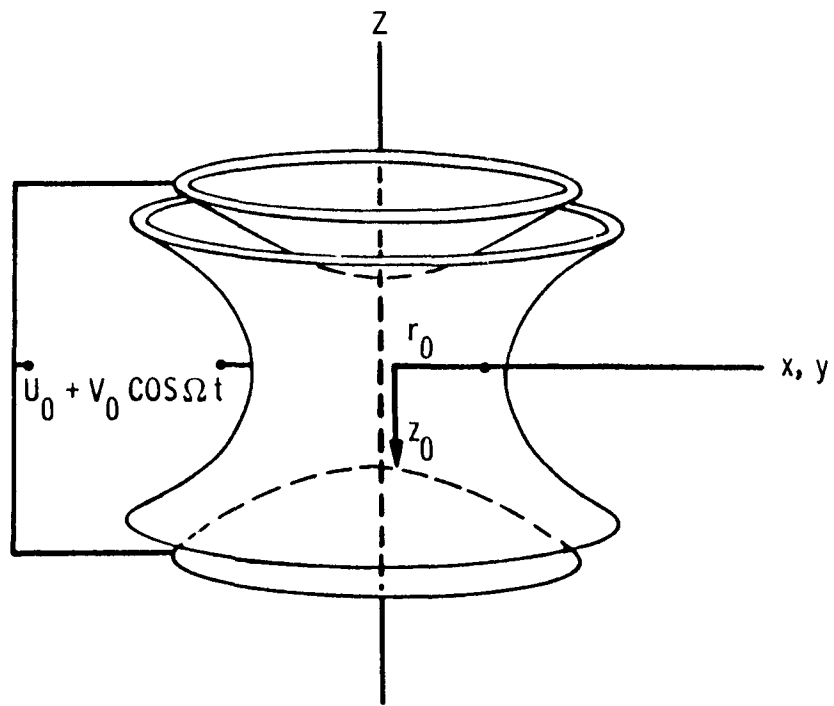

1. Electrode structure and voltages used in this work.

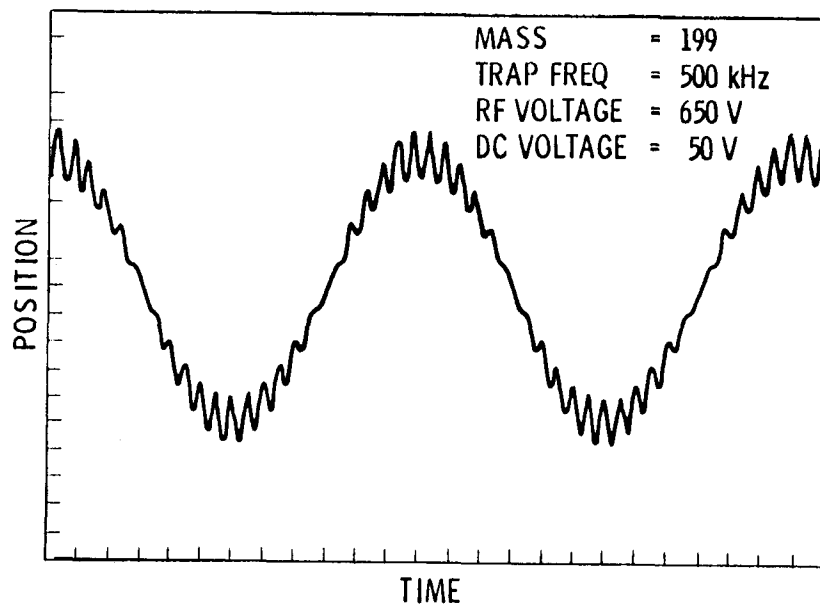

2. One dimensional motion for an ion in combined RF and DC trapping fields.

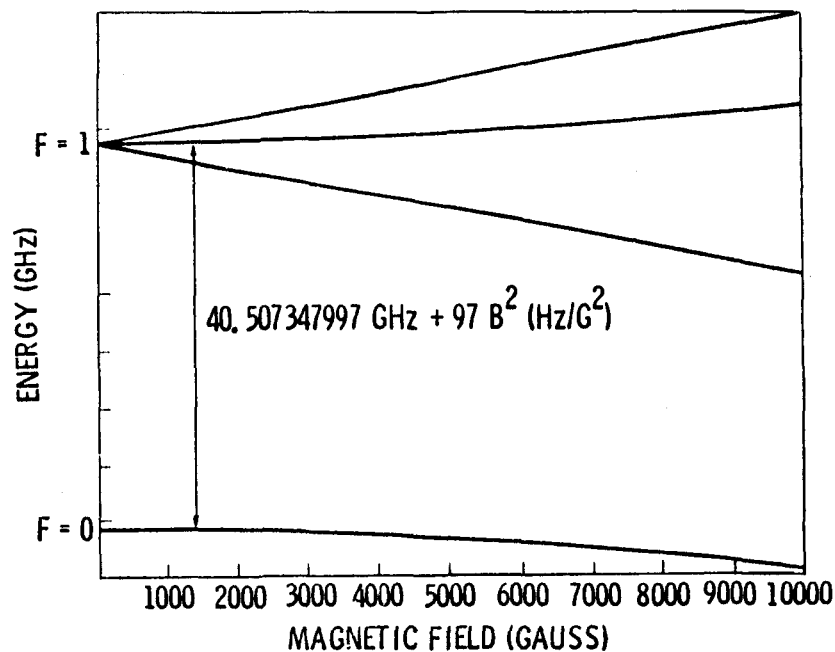

3. Energy levels of the ground state of $^{199}\text{Hg}^+$ in a magnetic field. The first order field independent transition used in this work is shown.

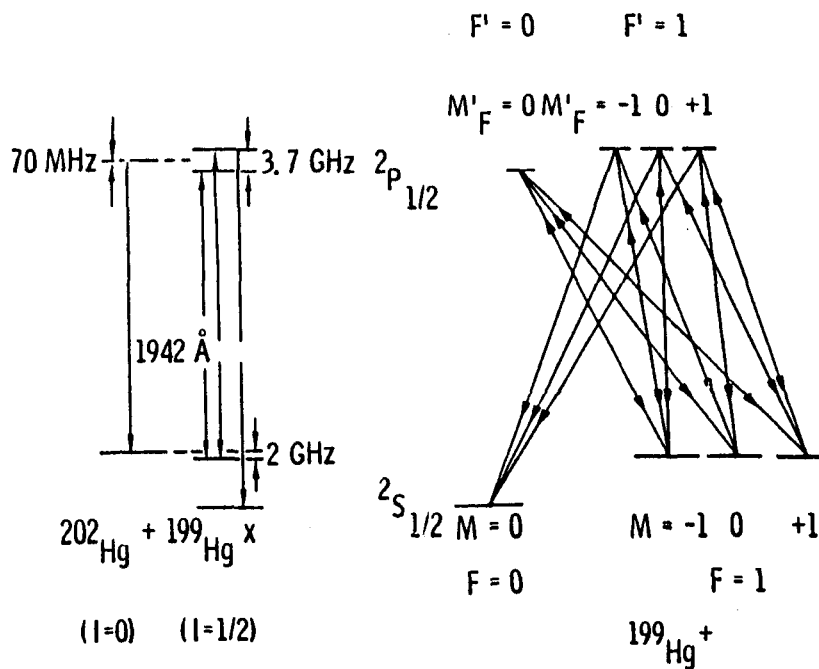

4. Ground and lowest optically excited states of $^{202}\text{Hg}^+$ and $^{199}\text{Hg}^+$ are compared showing how light from $^{202}\text{Hg}^+$ will pump $^{199}\text{Hg}^+$ ions into the ground state $^2S_{1/2}(F=0, m_F=0)$.

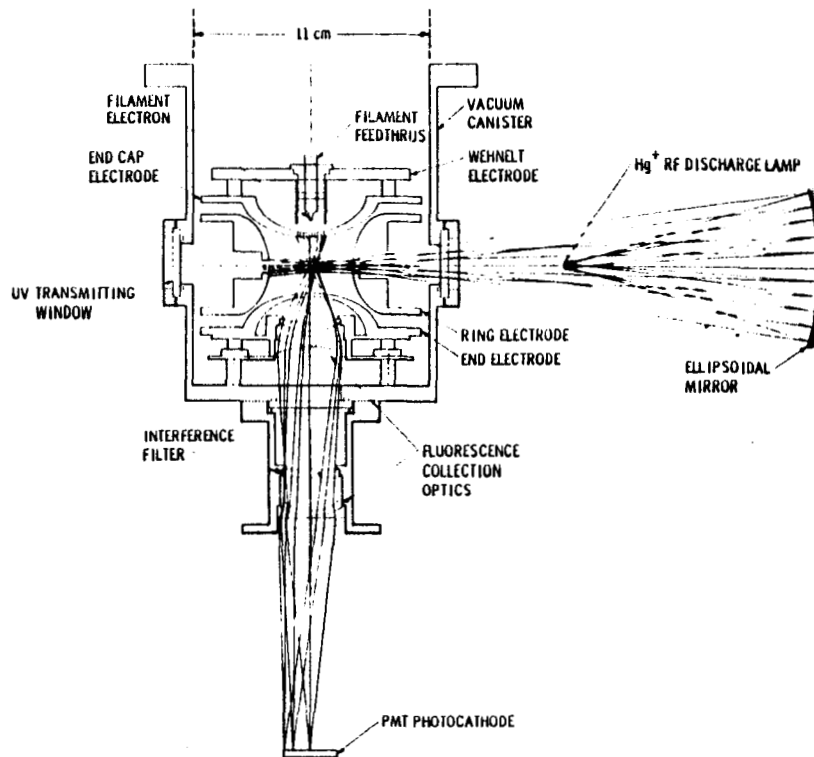

5. Cutaway drawing of the trapping electrodes, vacuum system, state selection input optics and fluorescence collection optics.

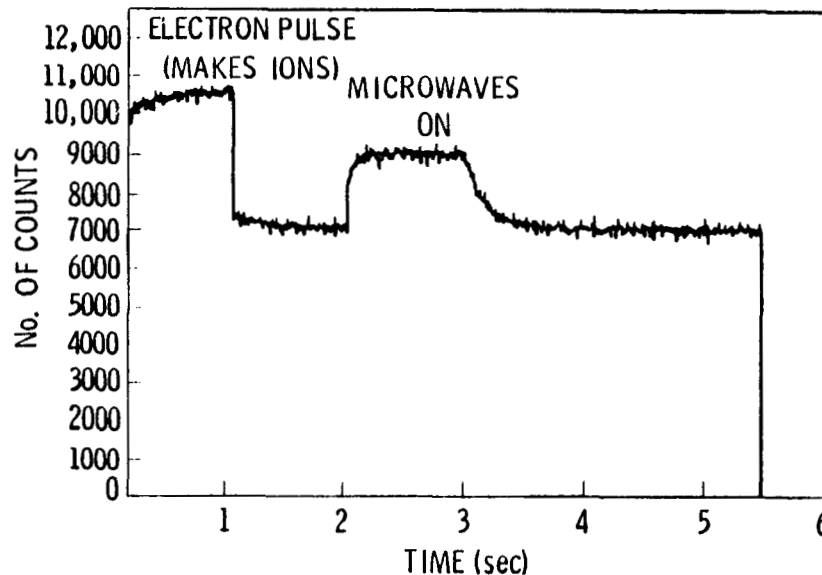

6. Light scattered from the ions during a 1 second microwave (40.5 GHz) pulse is detected together with stray light scattered from the windows and electrodes.

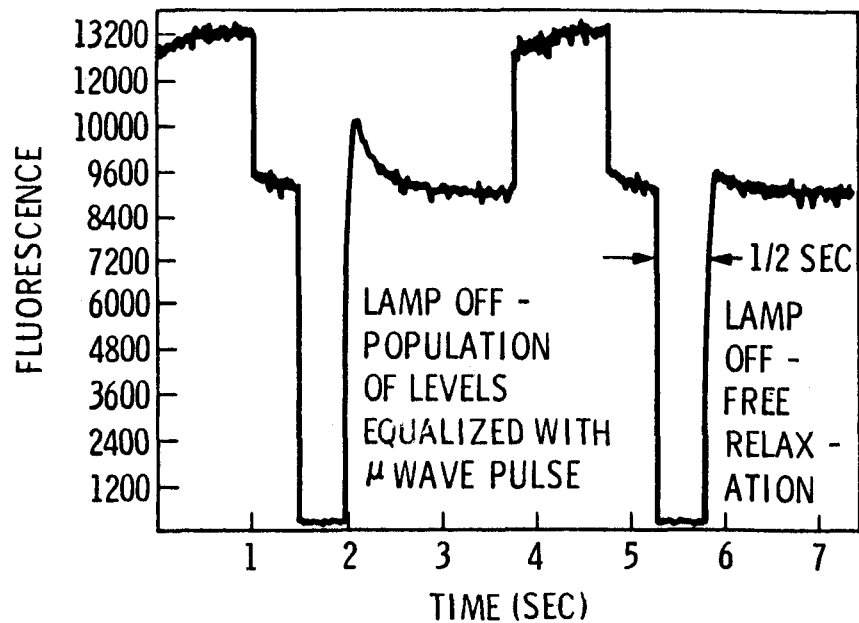

7. Optical pumping light from the lamp is switched off for 1/2 second intervals. During the first off period microwaves are applied to the ions equalizing the populations of the ($F=1, m_F=0$) and ($F=0, m_F=0$) levels. During the second dark period no microwaves are applied and the fluorescence that follows is a measure of the relaxation of the polarization during the 1/2 second.

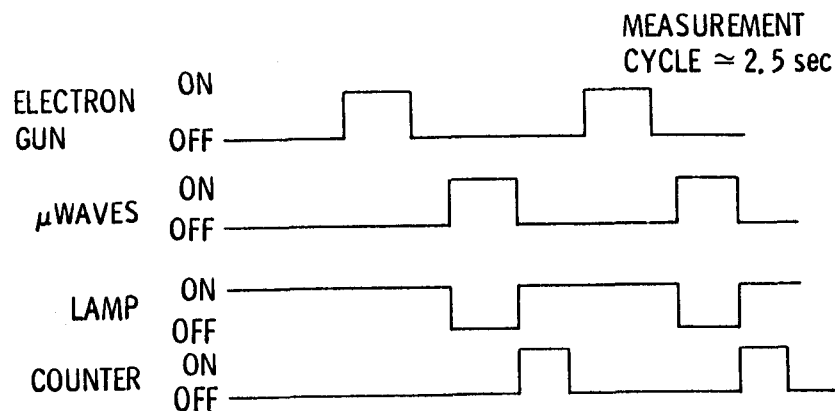

8. The sequence of operations used to measure the microwave absorption by the $^{199}\text{Hg}^+$ ions.

NUMBER OF SWEEPS 4
CENTER FREQ (Hz) 7.340077E+6
FREQ STEP (Hz) 0.2

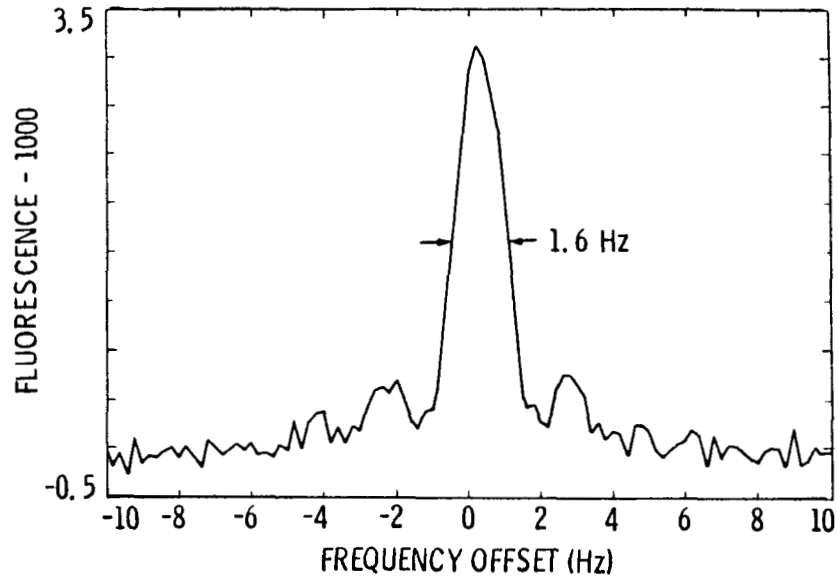

9. Atomic fluorescence as the frequency of the 40.5 GHz oscillator is swept through the atomic resonance.

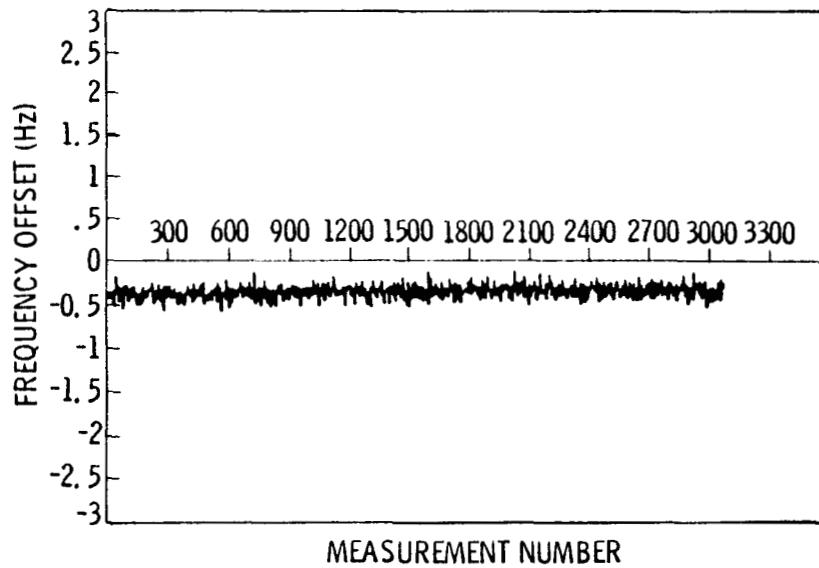

10. Frequency deviation of the 40.5 GHz oscillator while locked to the 1.6 Hz wide atomic resonance. Each measurement took 2.5 seconds.

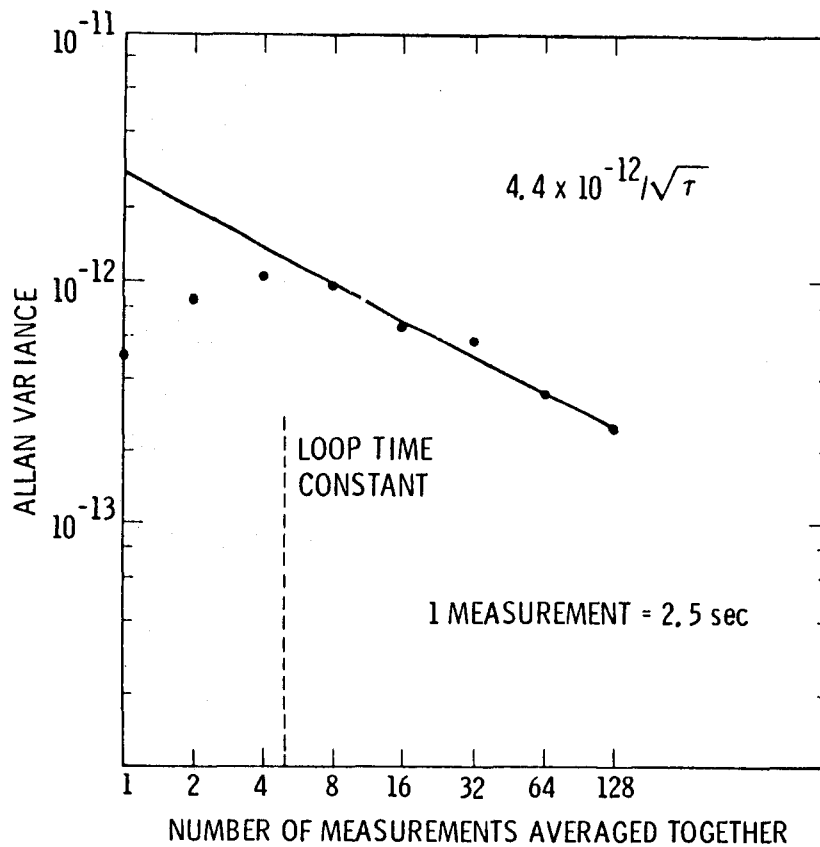

11. Allan variance of the sequence of center frequencies shown in figure 10. Multiply by 2.5 seconds to convert the horizontal axis to time.

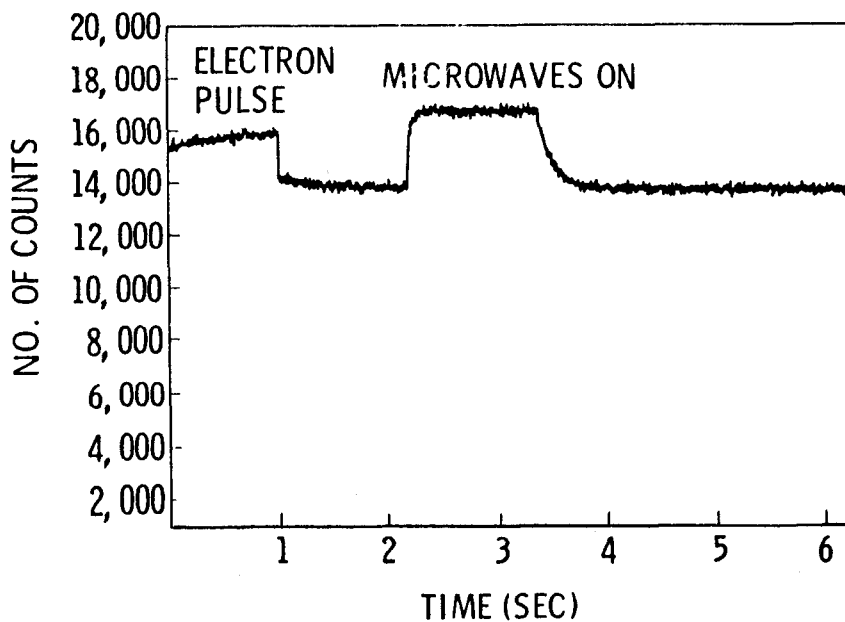

12. Repeating the measurement of figure 6 with the improved fluorescence collection system. This data was collected in half the time of that of figure 6. The new system has about 3 times the light gathering power as that shown in figure 5.

QUESTIONS AND ANSWERS

David Allan, National Bureau of Standards: What do you expect to obtain for the short-term stability?

Mr Prestage: In the next six months we expect to get an improvement of about two by going from the half-second integration time that we have now to a one-second integration, which we should be able to do with no trouble the way we are operating now. The new optical system and photo-multiplier tube should give another factor of as much as four. With those things we are talking, in the short term, of $1 \times 10^{-12}/\sqrt{\tau}$. Clearly we would have to some magnetic shielding and environmental control to get the long term continuation of that.