

AUTOMATION OF PRECISE TIME REFERENCE STATIONS (PTRS)

Paul J. Wheeler
U. S. Naval Observatory
Washington, D. C.

ABSTRACT

The U. S. Naval Observatory is presently engaged in a program of automating precise time stations (PTS) and precise time reference stations (PTRS) by using a versatile mini-computer controlled data acquisition system (DAS). The data acquisition system is configured to monitor locally available PTTI signals such as LORAN-C, OMEGA, and/or the Global Positioning System. In addition, the DAS performs local standard intercomparison. Computer telephone communications provide automatic data transfer to the Naval Observatory. Subsequently, after analysis of the data, results and information can be sent back to the precise time reference station to provide automatic control of remote station timing. The DAS configuration is designed around state of the art standard industrial high reliability modules. The system integration and software are standardized but allow considerable flexibility to satisfy special local requirements such as stability measurements, performance evaluation and printing of messages and certificates. The DAS operates completely independently and may be queried or controlled at any time with a computer or terminal device (control is protected for use by authorized personnel only). Such DAS equipped PTS are operational in Hawaii, California, Texas and Florida.

INTRODUCTION

One of the functions of the U. S. Naval Observatory is to provide a data base of precise time measurements which reference navigation systems timing to UTC (USNO). This is accomplished with measurements made at the Naval Observatory and at precise time stations (PTS) around the world. The quality of the measurements made at a PTS is often affected by personnel changes at the stations. In addition, the quantity of data is limited by the number of available man-hours. To improve both quality and quantity of this data the Naval Observatory has developed an automated data acquisition system (DAS) that is being installed in different configurations at the PTS's. There are operational systems presently installed in Hawaii, Texas, Florida and three in California. In the near future systems will be installed in Ohio, West Virginia and a second system in Hawaii.

The following will describe the different configurations and capabilities of these systems.

System Description (Figure 1)

The DAS is a mini-computer controlled system capable of monitoring locally available precise time signals such as LORAN-C, OMEGA and/or the Global Positioning System. In addition, the DAS can perform local standard intercomparisons. Computer telephone communications provide automatic data transfer to the Naval Observatory. After the data has been analyzed,

results and information can be sent back to the PTS to provide automatic control of remote station timing. Data analysis can also be performed by PTS personnel by utilizing the plotting and data printout capabilities of the DAS. The DAS also provides automated portable clock measurements, and printing of messages and certificates.

System Design (Figure 2)

The heart of the DAS is a Hewlett Packard (H/P) 9915 computer. The computer controls two interfaces, one an RS232 interface that is primarily used for data communications and an IEEE-488 (HPIB) interface for equipment control. In a basic system the HPIB connects to the computer one or two H/P 59307 VHF switches, an H/P 5328 or 5335 universal counter, and an Austron 2100 LORAN-C timing receiver. Once per hour under computer control the VHF switches connect up to 14 different timing signals (IPPS) into the universal counter. The universal counter is configured to make time interval measurements and transfer them to the computer for storage and subsequent transfer to the Naval Observatory. Each hour, under computer control, the LORAN receiver is locked onto a selected station, a time of arrival measurement is made, the data is transferred to the computer, and the LORAN receiver is initialized to acquire a different station. This computer control of the LORAN receiver allows different stations and/or chains to be monitored with a single receiver. A time tag for the data is obtained from the LORAN receiver or from an internal clock in the computer if the LORAN receiver malfunctions. The data is also labeled with the Modified Julian Date that is maintained by the computer, and the LORAN data is labeled with the chain repetition rate and station ID. A DAS in this configuration can store two days of data in computer memory and up to 30 days on the built in tape drive. To reduce the problems caused by magnetic tape and tape transport wear, the system programs are stored on EPROMs (erasable programmable read only memory) in the computer. These programs are loaded and run on power-up without human intervention, eliminating the need for computer back-up power.

The RS232 interface connects the computer to a standard dial up telephone line via a 1200 baud modem. This allows data transfer, system control, and/or system diagnostics to be performed with a remote computer or communications terminal. To communicate with a remote DAS, dial the telephone number, respond to the request for your ID, then respond to the request for your operation codes. The ID "USNO" is provided for PTTI users; this code allows access to the DAS data without the capability of interfering with the DAS operation. The operation code in most cases is a one or two digit number that tells the DAS what data you would like transferred (refer to Table 1 for example). Upon request the DAS stored data is transferred to the USNO or PTTI user in the form of Modified Julian Date, Universal Time, clock time interval measurements, LORAN-C chain, and LORAN-C time interval measurements. Remote system control provides, for example, the ability to update the DAS date, time of day, and the number of leap seconds, as well as to monitor clock time interval measurements and LORAN-C data in real time. Time of day, station GRI (Group Repetition Interval), receiver gain, signal to noise ratio, receiver status, and cycle number from the LORAN receiver can also be monitored. Remote system diagnostics can be performed on the VHF switches, LORAN-C receiver, and time interval counter. In addition to the precoded diagnostics any allowable interface bus commands can be sent to each piece of equipment allowing complete equipment control from a remote terminal. Other diagnostics include a table of amplitude and frequency measurements of each clock signal connected to the VHF switches. Comparing these measurements to the measurements in the table made during system initialization helps to determine the integrity of the signals and cables in the system. The number of power failures at the PTS are counted and stored to help analyze equipment failures. The programs are designed so that when a software or firmware error occurs, the program will recover and continue; however, the error code and the program line number where the error occurred are stored and may be read during data communications. This aids in software debugging while the DAS is operating at the PTS.

Soon after installation of DAS's in the field new requirements evolved and subsequently the DAS's capabilities were expanded (refer to Figure 3).

One of the new requirements was to provide a printout of the USNO's GPS timing data in the computer facility at the GPS master control site located at Vandenberg AFB, California. The printer was to be located 1000 feet from the DAS and the data printed out had to be free of any transmission errors. To connect the printer to the DAS, short-haul modems and a Black Box "Fall Back Switch" (FBS) were used. The modems extend the RS-232 communications from the DAS to the printer. The FBS allows both the data communications modem and the printer via short-haul modems to be connected to a single RS-232 computer interface. To insure error free data, two error check numbers are calculated by the USNO computer and transmitted with the data. When the data is received at the DAS, the error check numbers are calculated by the DAS computer and compared to those sent with the data. An affirmative acknowledgement is returned by the DAS if the calculations agree; otherwise, retransmission of the data is requested. Data and messages can also be sent from a data terminal. However, calculation of the error check codes by hand is not practical. To solve this problem, a special error check code is sent with the message. This code tells the DAS to transmit the entire message back to the sender. The sender can then check the message for errors and transmit an affirmative acknowledgment or retransmit the message.

Another requirement was to monitor the OMEGA navigation system. The Black Box FBS was used to connect a Magnavox 1104 OMEGA monitor to the DAS, and an H/P Winchester disc was added to accommodate the storage of the large amount of data provided by the OMEGA receiver. The OMEGA data is stored in a 100 day circular file on the disc. With the use of the DAS data communications this data is available to the U.S. Coast Guard for analysis. The communications modem used in this DAS was a dual speed modem, 300 and 1200 baud. This modem and the computer identify the speed of the call-in modem and set their own communications speed accordingly. This feature allows a larger variety of data terminals and even the most inexpensive computers to communicate with the DAS.

In January 1983, the Vandenberg AFB contracted with the USNO to design and build an automated timing system for their Precise Measurement Electronics Laboratory (PMEL). This PMEL is a Precise Time Reference Station (PTRS). This was the beginning of a second generation DAS with several new capabilities (refer to Figure 4). This new system consisted of the computer, two VHF switches, the LORAN receiver, time interval counter, Winchester disc, a second H/P 9915 computer with keyboard and monitor, a Timing Systems Technology (TST) precision digital multi-timescale clock, TST microphase stepper, Stanford Telecommunications Inc. (STI) 502 GPS receiver, an H/P graphics plotter, and an H/P printer.

The keyboard, monitor and second computer are used as a local terminal. This terminal provides for local control of the system, data analysis, plots and printouts of the collected data, and the printing of reports and messages. The programs for the local terminal are soft-key controlled. Programs are loaded and run by pressing a single key and require no programming knowledge. The terminal computer is connected to the DAS computer and the other equipment in the system by the HPIB. Both computers, in turn, can act as the system controller. This allows both computers to access the same disc in order to store and retrieve data or to control the other equipment in the DAS in order to collect the data. The plotter and printer are connected to the terminal computer with the H/P interface loop (HPIL). The use of the HPIL allows the printer and plotter to be located with the keyboard and monitor in an office, while the computers and other equipment are kept in a laboratory environment. Plotting, printing and programming can also be performed with the terminal computer without tying up the HPIB interface which is required by the DAS for data collection.

The DAS computer, as in other DAS's, is for control of the system, timing equipment and communications. The DAS computer maintains priority control over the HPIB and, therefore, priority control over the equipment in the system. In order for the terminal computer to access the disc or control the equipment the terminal computer must obtain HPIB control from the DAS computer. The DAS computer may pass control, deny or take control away from the terminal computer.

The microphase stepper and digital clock were added to provide a computer slewable 1pps and are connected to the system via the HPIB. With the microphase stepper, the 1pps from the digital clock can be stepped in time in one picosecond steps or the 1pps can be slewed in parts as small as ten to the minus seventeenth. This control of station timing can be done with the local terminal, remote terminal or remote computer. The microphase stepper and digital clock are completely programmable by remote computer or terminal. This provides for automated insertion of leap seconds into the station timing and allows for remote diagnostics in the event of equipment failure.

The GPS receiver provides primary data for control of the station timing. A tracking schedule is loaded into the DAS computer from the USNO. This schedule is initialized so that the GPS receiver at the remote station and the GPS receiver at the USNO collect data from the same GPS satellite at the same time. The data is reduced and stored on disc with the start time, stop time, space vehicle number, slope and rms of the data, and the number of samples. Each day the USNO computer calls and collects the GPS, clock and LORAN data from the DAS. The DAS GPS data is compared with the USNO GPS data. The difference between the remote station timing and UTC USNO is then calculated and when needed control information is sent back to the DAS to automatically correct station timing. To prevent transmission errors in the timing control message, the entire message is retransmitted to the sender. The sender must then acknowledge whether the message was received correctly or if retransmission is required. After an affirmative acknowledgment is received by the DAS, the DAS sends the control message to the microphase stepper. If no errors are indicated by the microphase stepper the DAS computer queries the microphase stepper for the last control message received. The control messages are compared by the computer and the results are sent back to the sender informing him that the control was accepted or that retransmission is required. If an error occurs in the microphase stepper, an error code, the date and time are stored on disc. This information can then be retrieved by USNO for analysis.

The graphics plotter and associated software provide plots of any of the collected time interval data. This includes the data from the GPS receiver, the LORAN receiver, and all equipment connected to the VHF switches. The data is collected once each hour and stored on disc in a ten day circular file and may be used to produce plots one to ten days long. This data can also be printed on the printer for numerical analysis or to edit bad data points. Plots with reduced resolution can be produced on the monitor for quick analysis.

A connection through the VHF switches is provided for automated portable clock measurements. The computer asks the operator pertinent information for printing a portable clock measurement certificate; i.e., clock serial and model number, owner's name and address, and the personnel making the measurement. The computer then instructs the operator through a procedure that calibrates the cables being used to connect the clock to the measurement system, measures the time interval between the system time and portable clock, and prints out a certificate of the measurements made. The data that is printed on the certificate is also stored on the disc for transfer to the USNO.

One of the functions of the Vandenberg PMEL is to calibrate other PTS's. A computer program was added to this DAS which significantly reduces the amount of labor previously required to calculate and report these measurements. After portable clock measurements are made at the

PMEL and the remote PTS, the data is entered into the computer. The computer then locates data on the disc from previous clock measurements made at the PTS, calculates the long term drift rate of the PTS timing, calculates the present time offset between the PTS and UTC (USNO), prints out an extensive form with all pertinent data, and stores the data on the disc for future reference.

SUMMARY

The DAS's described are systems that are already operational at several PTS's. Some of the DAS's have been operating for two years providing data for the USNO. The equipment used in these systems was selected for its reliability, accuracy, and availability. The DAS can be easily configured in many different ways to tailor the system to the needs of the particular PTS. The software for the computers is written as modules and can be connected together to conform with the equipment in the system. Other equipment and software can be easily added to the DAS as requirements evolve.

The USNO will continue to install these DAS's at selected PTS's and PTRS's in order to improve the monitoring and dissemination of precise time. The USNO is also willing to design, build and control DAS's for other precise time users.

USNO AUTOMATED REMOTE DATA ACQUISITION SYSTEM (DAS)

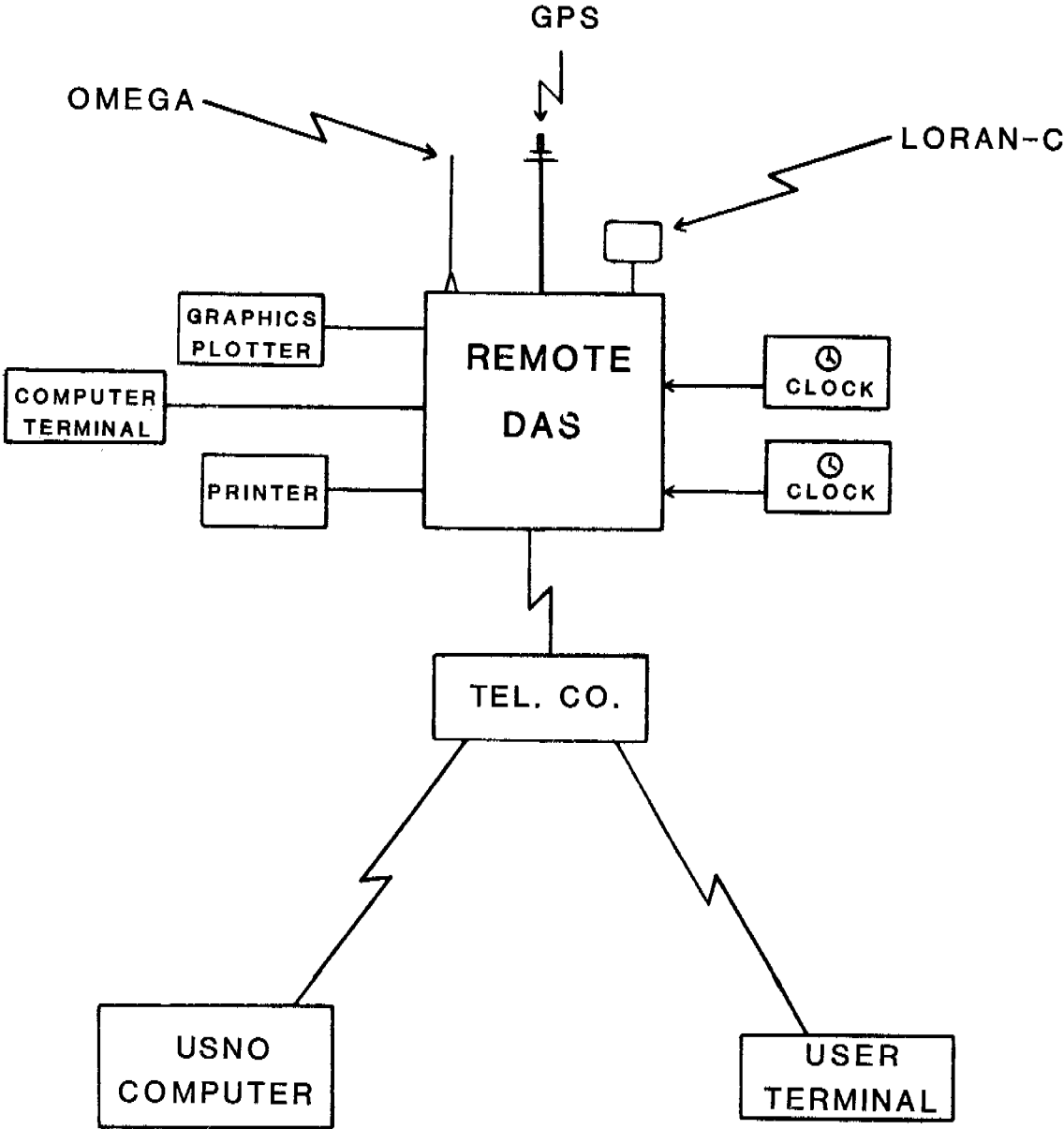

FIGURE 1

PTS DAS

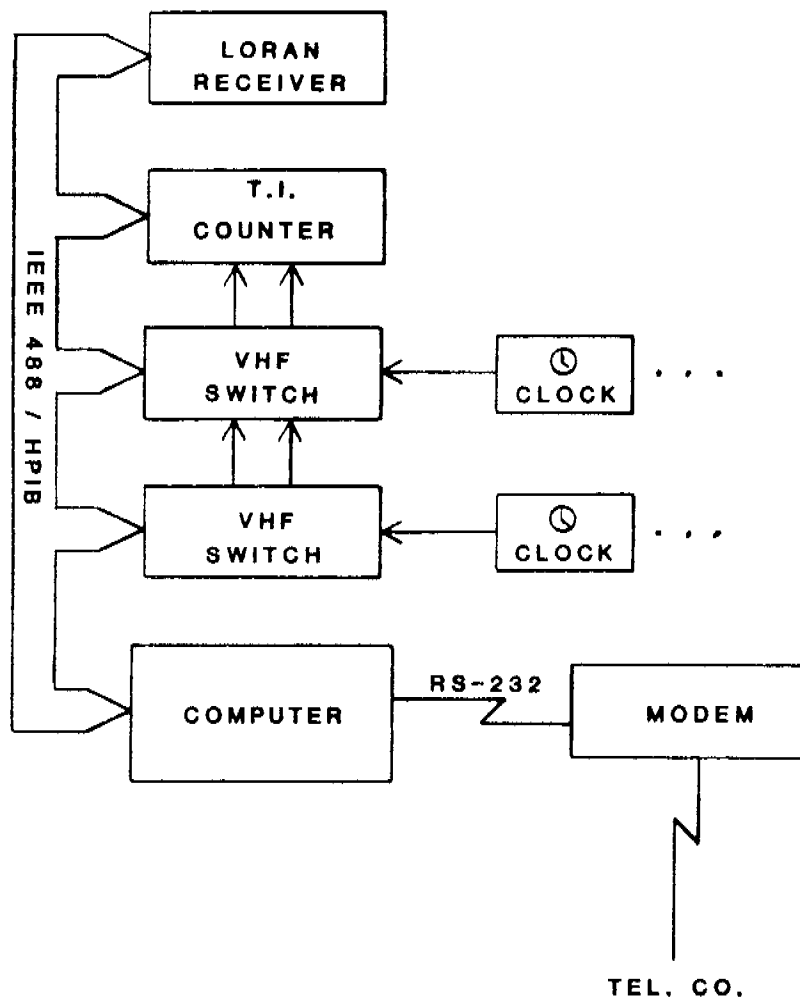

FIGURE 2

DAS OPTIONS

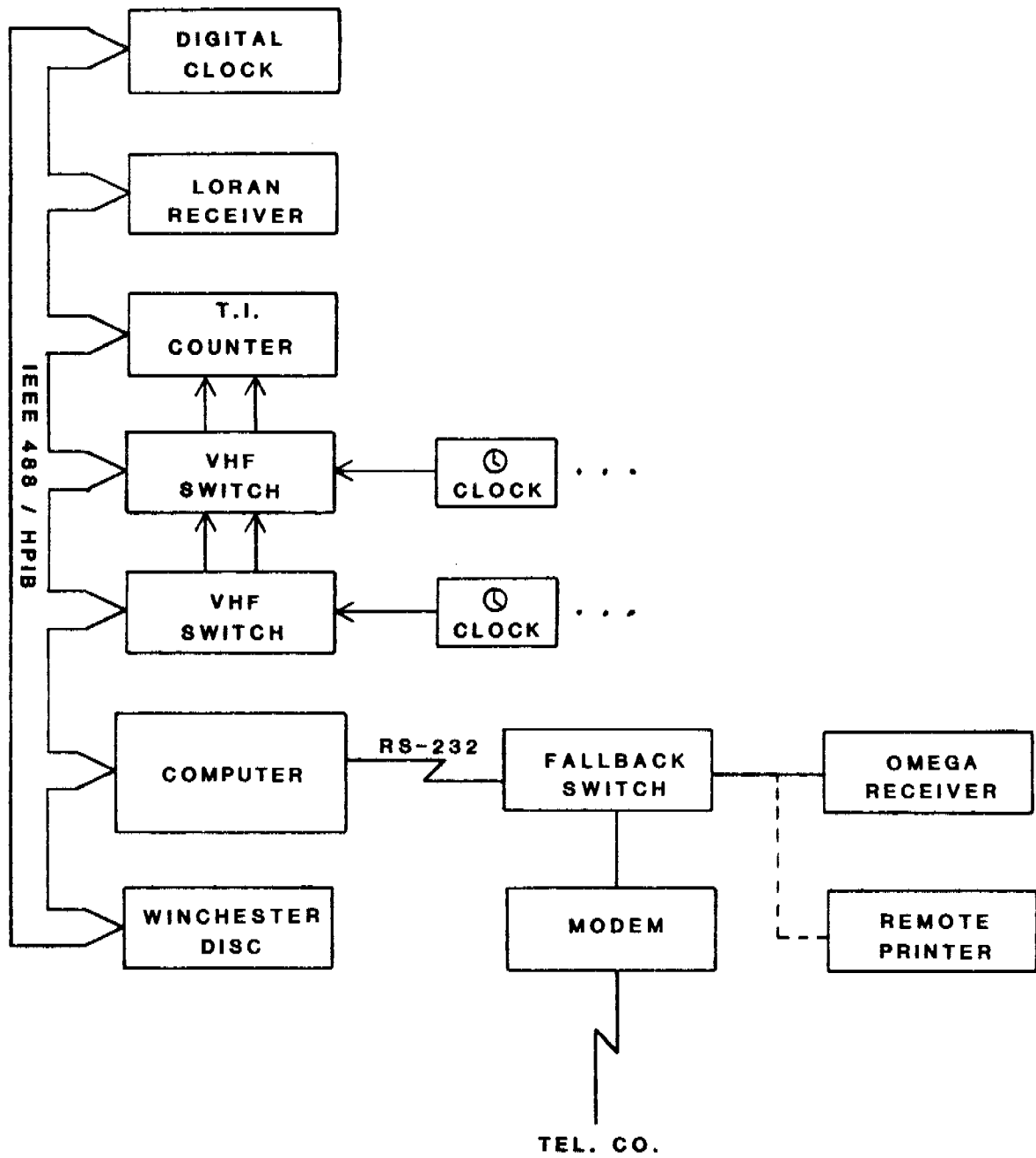

FIGURE 3 48

PTRS DAS

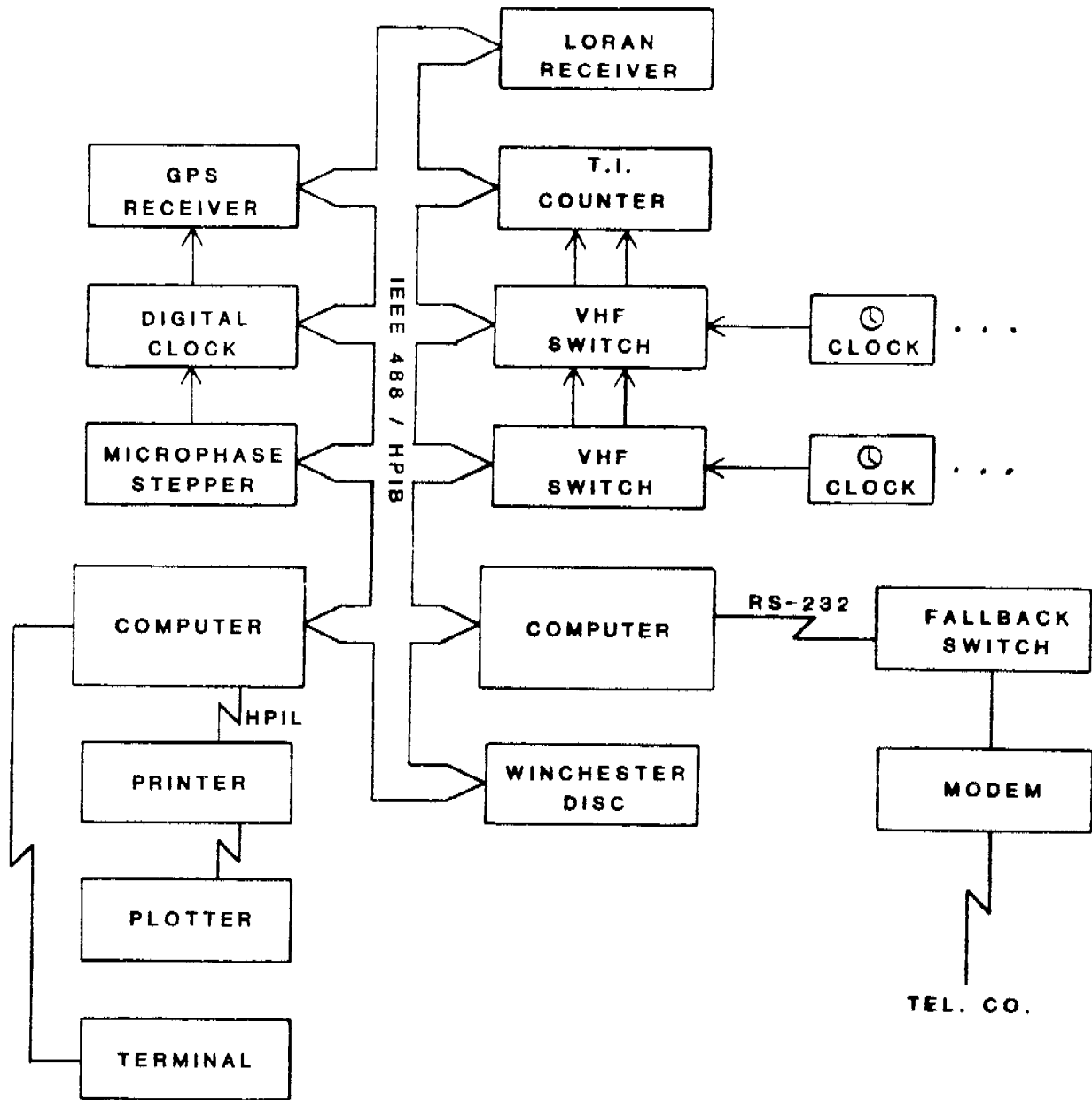

FIGURE 4 49

COMMUNICATION CODES

	1	=	TERMINATE COMMUNICATIONS
	2XXZ	=	DATA TRANSFER (XX = # OF CHANNELS, Z = # OF DAYS, DEFAULT = 2162)
	3X...	=	TIME INTERVAL COUNTER CONTROL (X... = ANY VALID HPIB COMMAND)
	31	=	PERFORM A TIME INTERVAL MEASUREMENT
	32	=	T.I. COUNTER SELF CHECK
	4X...	=	VHF SWITCH CONTROL
P	5X...	=	LORAN RECEIVER CONTROL
P	6XX	=	LEAP SECONDS CONTROL (XX = LEAP SECOND COUNT) IF XX IS INCREMENTED BY 1 THEN THE TST DIGITAL CLOCK IS CORRECTED AT 2400 UT.
	7	=	NUMBER OF STATION POWER FAILURES
A	71	=	PRINT OUT VHF SWITCH SIGNAL TABLE
B	71	=	PRINT OUT THE LAST 10 PORTABLE CLOCK MEASUREMENTS
	72	=	PERFORM ALL T.I. MEASUREMENTS WITHOUT STORING DATA
P A	73	=	RESET POWER FAILURE COUNT
B	73	=	PRINT OUT THE LAST 10 DAYS OF GPS DATA
P	74	=	PRINT OUT PROGRAM AND MICROSTEPPER ERROR LIST AND OPTION TO ERASE DATA FILES ON TAPE
A	75	=	PERFORM VHF SWITCH SIGNAL ANALYSIS
B	75	=	GPS RECEIVER INTERNAL TRACKING SCHEDULE
P A	76	=	CORRECT VHF SWITCH SIGNAL TABLE
P B	76	=	RESET POWER FAILURE COUNT
P	77	=	RESET AND INITIALIZE LORAN RECEIVER
P	78	=	READ COMPUTER INTERNAL CLOCK (TIME OF DAY)
P	79	=	SET COMPUTER INTERNAL CLOCK
	8	=	PRINT OUT LORAN RECEIVER STATUS TABLE
P A	81	=	REMOTE PRINTER INPUT (1,1 = DEFAULT CHECK SUM AFTER cnt1 D)
B	81	=	PRINT OUT VHF SWITCH CLOCK LABELS
P	82	=	HPIB OR HPIL PRINTER INPUT (1,1 = DEFAULT CHECK SUM AFTER cnt1 D)
P	83	=	MICROSTEPPER CONTROL INPUT
P A	84	=	READ DATA ON MAGNETIC TAPE
B	84X...	=	CONTROL TST CLOCK (DEFAULT = T read clock), (1C = UTC)
	85	=	PRINT OUT THE LAST 24 HOURS OF OMEGA DATA
P	86	=	GPS RECEIVER DATA REDUCTION SCHEDULE
	OMEGA	=	PRINT OUT 1 TO 100 DAYS OF OMEGA DATA

- NOTE: (P) INDICATES THAT THE CODE ACCESS IS PROTECTED AND DEPENDENT ON ID ENTRY
 (A) INDICATES CODES THAT ARE USED FOR PRECISE TIME STATIONS
 (B) INDICATES CODES THAT ARE USED FOR PRECISE TIME REFERENCE STATIONS

TABLE 1

QUESTIONS AND ANSWERS

MR. WARD:

Samuel Ward, Jet Propulsion Laboratory. Why weren't multiple-time interval counters used?

MR. WHEELER:

We haven't had a problem with a single-time interval counter. We didn't deem it necessary to have more than one time interval counter.

MR. WARD:

But with a single-time interval counter, the epoch of the measurement is different for each. You can't make two measurements at the same time, nor can you use the integrating features that are built into the counter.

MR. WHEELER:

Yes, measurements are made sequentially.

MR. WARD:

But in cross correlating data from the different measurements, if the epochs are not the same, then you really have to make adjustments because it's not truly simultaneous measurement.

MR. WHEELER:

Yes. The simultaneous data from the G.P.S. receiver is not measured to the time interval counter.

MR. WARD:

Well, G.P.S. has its own counter built in.

MR. WHEELER:

Yes.

MR. WARD:

We think that for the measurements made on the Loran and Omega and some of the other measurements, the time interval counter was used.

MR. WHEELER:

We aren't depending on the true common view measurements of the clocks, of the locally available clocks in the Loran.

DR. WINKLER:

I would like to comment on that, on the question: "Why are these measurements not being made simultaneously and what is the maximum error which you get by not doing so?"

Well, if you make your measurements sequentially between high performance clocks, the maximum time error which you make in a measurement which is done in ten seconds or fifteen seconds is less than one nanosecond; and considering all your other errors in the system, that is not important, of course. That's the main reason why in the interest of being economical, the multiple counter system has not been selected.