

## A Spaceborne Hydrogen Maser Design\*

A.E. Popa, H.T.M. Wang, W.B. Bridges<sup>†</sup>, J.E. Etter, and D. Schnellker  
Hughes Research Laboratories  
Malibu, California

F.E. Goodwin, C. Lew, and M. Dials  
Hughes Space and Communications Group  
El Segundo, California

### ABSTRACT

This paper presents the design for a space-qualifiable hydrogen maser optimized to fit into the Naval Research Laboratory's NTS-3 spacecraft. The design is derived from our experience with an advanced development model (ADM) developed for and delivered to the Naval Research Laboratory (NRL). The NTS-3 satellite is a technology satellite built as part of the Navy support for the NAVSTAR/Global Positioning System

### INTRODUCTION

The excellent performance and superior stability of the atomic hydrogen maser are well known. However, the sizes and weights of typical masers designed for ground-based applications are not suitable for spaceborne applications. In past maser designs a long hydrogen-beam drift space was considered essential for effective state selection, and large sputter ion pumps were employed to maintain the high vacuum necessary for maser operation. For spaceborne applications the maser must be smaller and lighter than past designs and operate with a minimum of operator intervention.

#### Spacecraft Constraints

The spaceborne maser must interface with the NTS-3 spacecraft, which will be built by the Naval Research Laboratory (NRL) for launch in 1981. The spacecraft constraints shown in Figure 1, include a 15 in. (38 cm) maximum allowable diameter and a maximum length of 30 in. (78 cm). The maser must weigh less than 100 lb and consume less than 100 W from the spacecraft power bus. The operational temperature range will be  $20^{\circ}\text{C} \pm 10^{\circ}\text{C}$  and an operating life greater than 5 yr is required.

---

\*This work has been supported by the Naval Research Laboratory under Contract N00014-75-C-1149.

<sup>†</sup>Present address: California Institute of Technology, Pasadena, CA 91125.

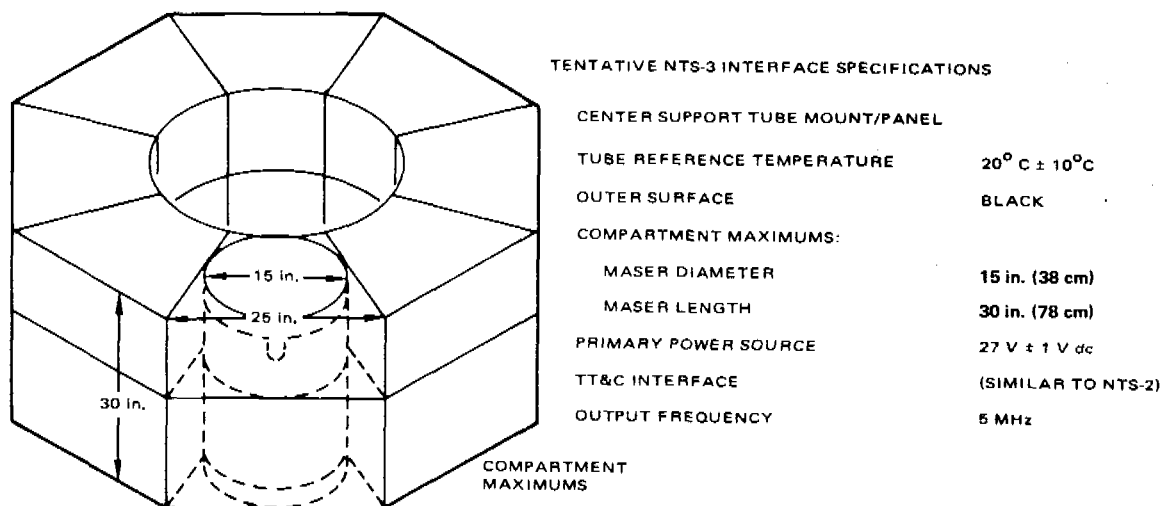

Figure 1. Tentative NTS-3/hydrogen maser interface layout.

#### System Description

A block diagram of our advanced development model maser (ADM) is shown in Figure 2 and a photograph of the physics unit is shown in Figure 3. We anticipate the spaceborne design will be quite similar to the ADM units. The spaceborne design is shown in cross section in Figure 4 and a detailed description of each subsystem follows.

#### Hydrogen Flow

A space-qualified high-pressure hydrogen storage and control subsystem has been selected for the space maser to ensure reliability and to minimize development costs. A 10-yr supply of hydrogen gas is stored at 1500 psi in a small lightweight pressure vessel and the subsystem is activated, on command, by a high-pressure solenoid valve. A strain gauge sensor measures the tank pressure for telemetering, and a space-qualified mechanical pressure regulator reduces the hydrogen pressure entering the palladium valve assembly to 10 psi. The hydrogen pressure between the palladium valve and the mechanical regulator is also measured and telemetered.

The palladium valve assembly shown in Figure 5 is used to reduce and regulate the hydrogen pressure in the dissociator to 50 mTorr ±1%. Incorporated into the palladium valve assembly are a temperature-stabilized thermistor bridge to measure dissociator pressure, and two redundant palladium valves which diffuse hydrogen when heated by an electric current from the hydrogen flow control servo. The dissociator pressure is telemetered and one of the parallel palladium valves

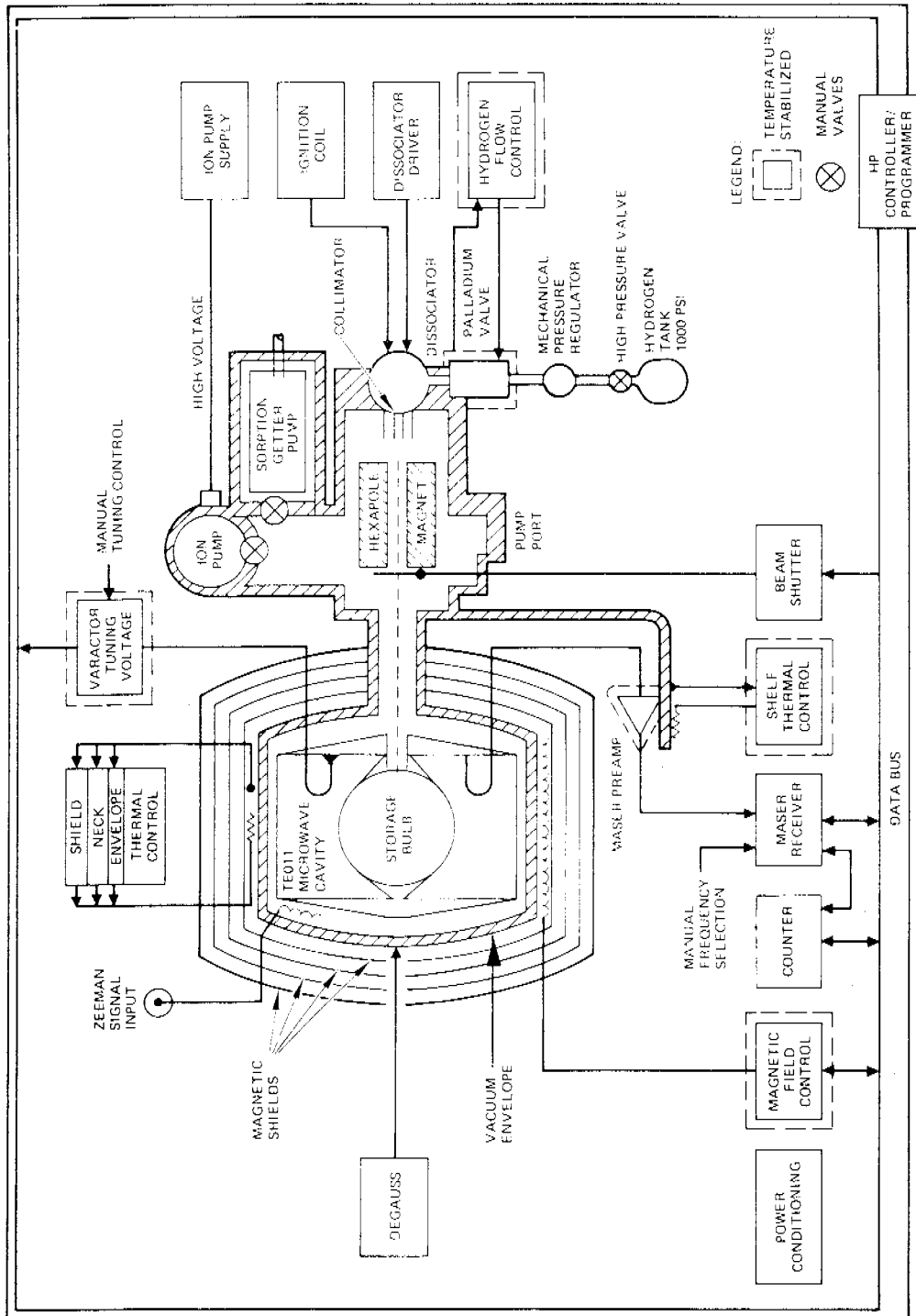

Figure 2. Hymns III physics unit and electronics unit interface.

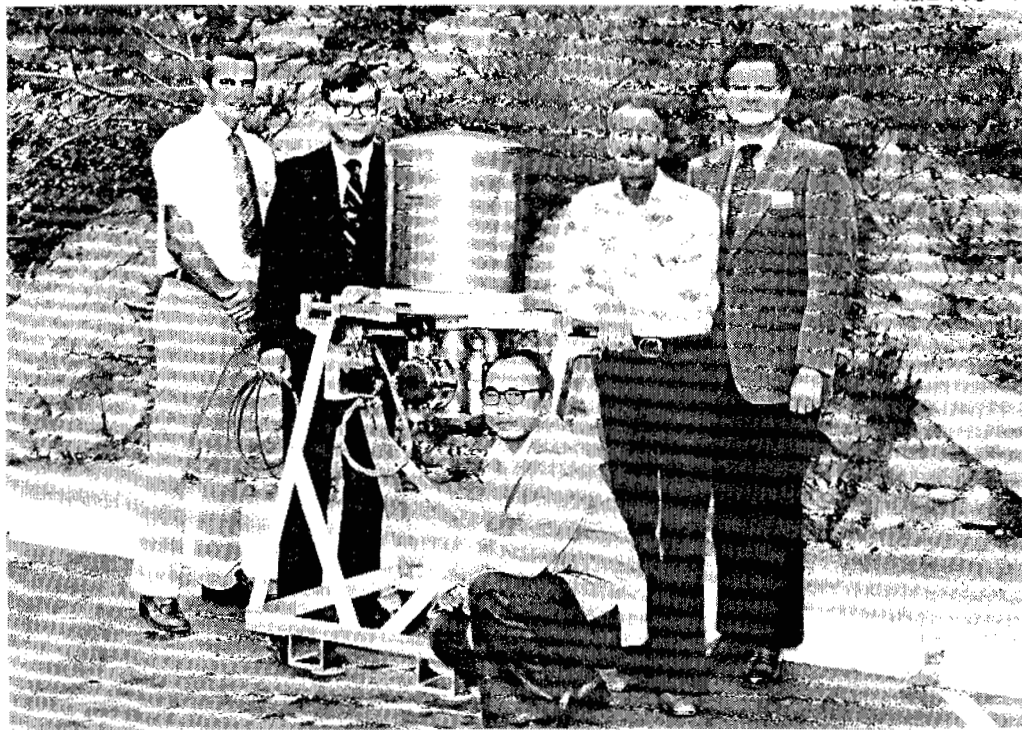
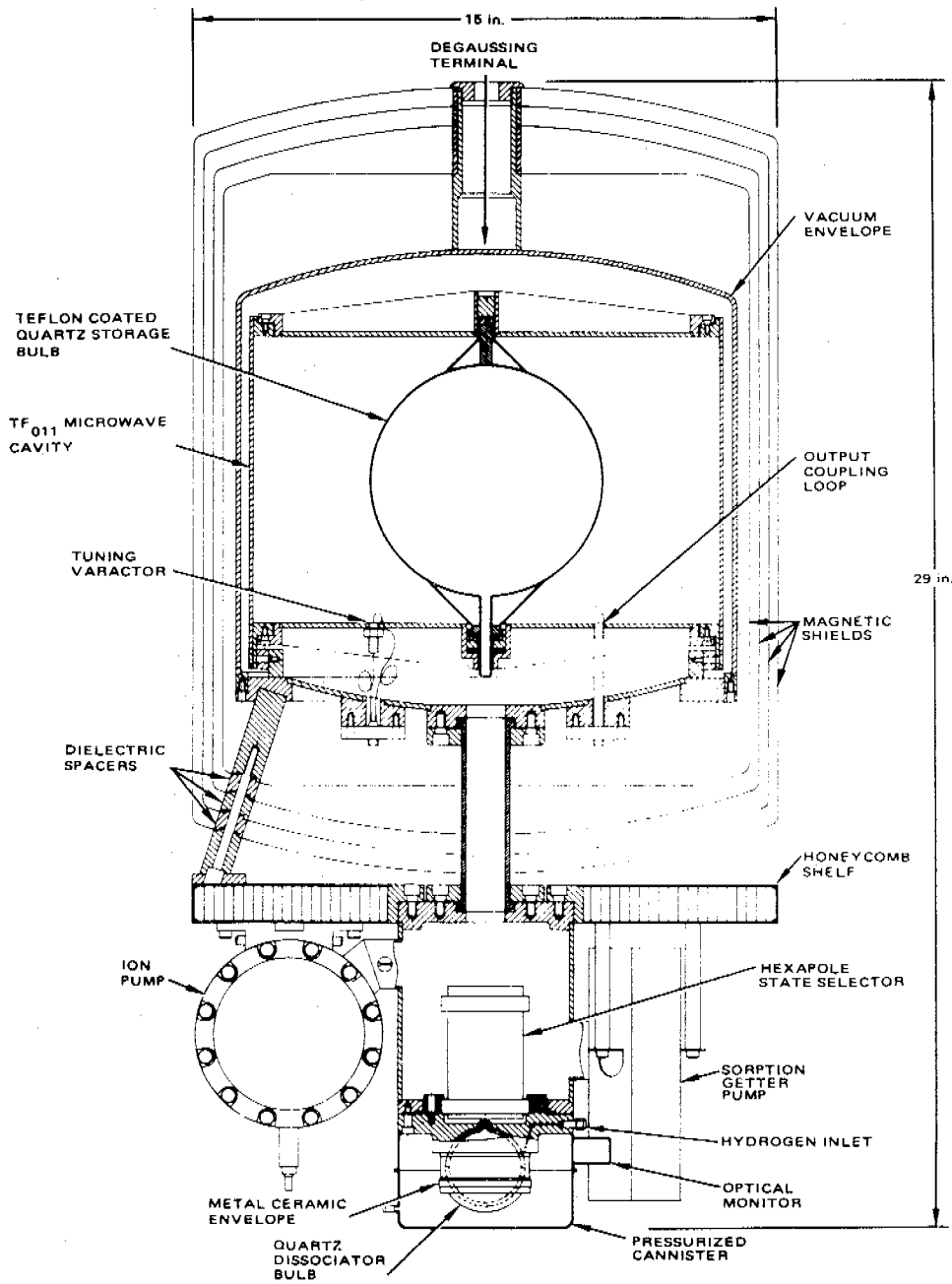

Figure 3. HYMNS III advanced development model physics unit.



a) CUTAWAY SIDE VIEW

NOV 1977

Figure 4. Engineering development model layout.

operates the system when selected by command. Metal tubing is to be used between the pressure tank and the dissociator input port. For diagnostic purposes, the hydrogen flow control servo can be programmed through 256 pressure levels.

### Dissociator

Molecular hydrogen ( $H_2$ ) at the regulated 50 mTorr pressure is dissociated into atomic hydrogen (H) in an rf discharge. This discharge is ignited, on command, and sustained with 5 W of 150 MHz power supplied by the dissociator driver. Both the absorbed and reflected dissociator power levels are measured and telemetered. The dissociator shown in Figures 6 and 7 has a metal-ceramic envelope for thermal and mechanical strength and encloses a 2-in. diam. pyrex bulb to confine the hydrogen atoms.

6014-19

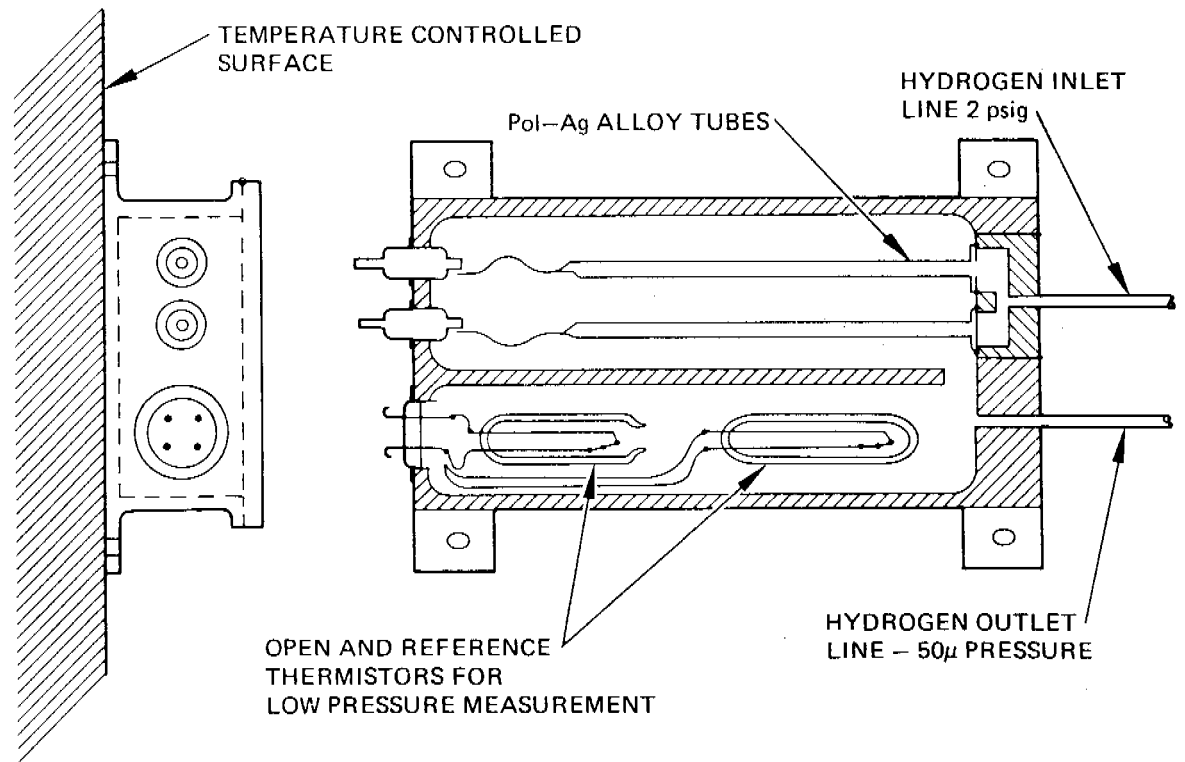

Figure 5. Integrated Pd-Ag regulator and thermistor pressure sensor. Electrical connections are made through vacuum tight ceramic feedthrough terminals.

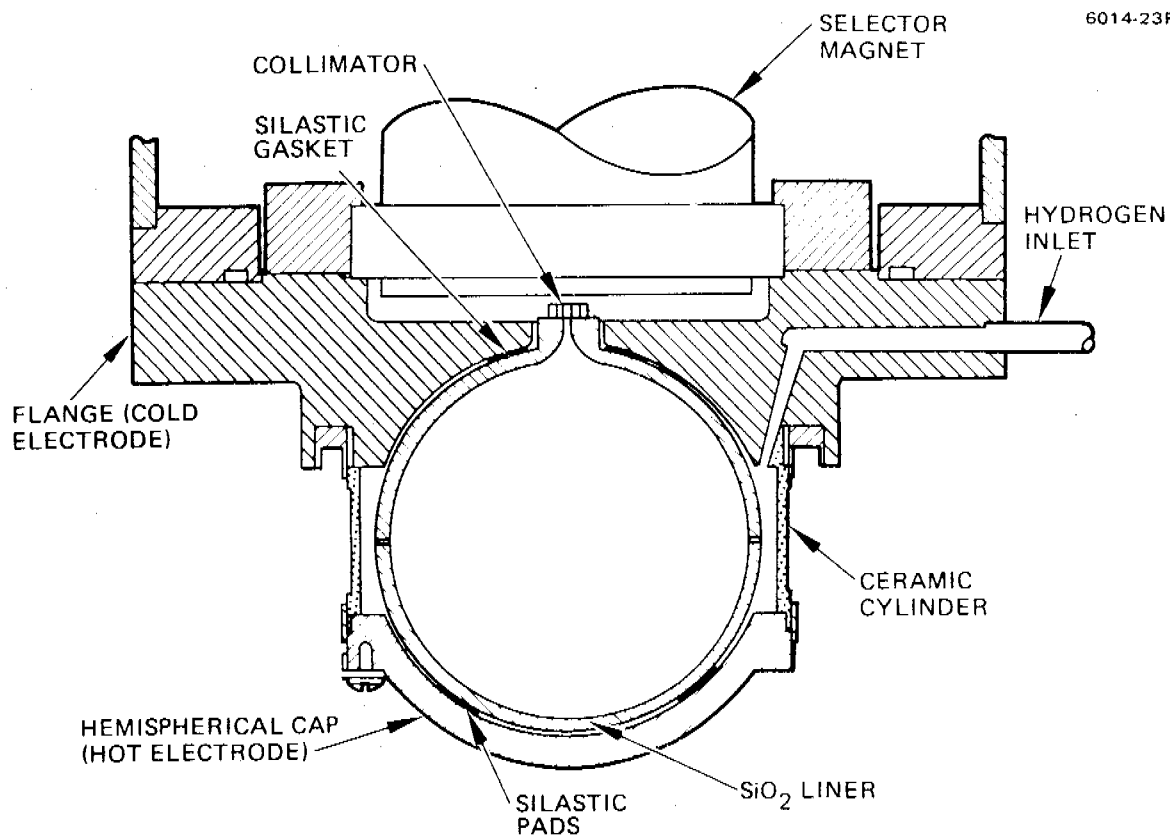

Figure 6. Proposed hydrogen dissociator design utilizing a metal-ceramic vacuum envelope with a spherical SiO<sub>2</sub> liner.

M12026

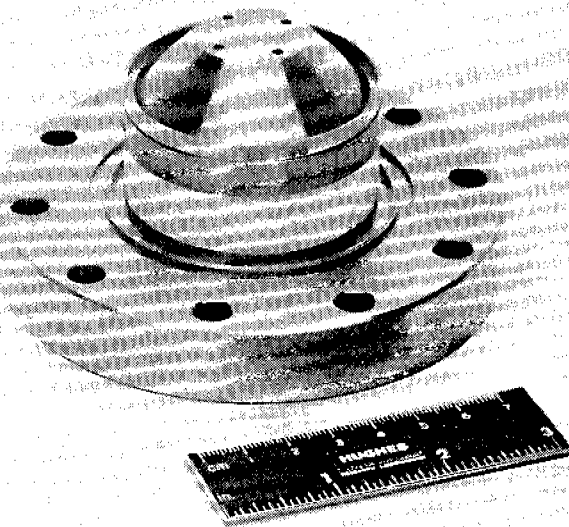

Figure 7. Laboratory prototype of hydrogen dissociator.

### State Selector

After leaving the dissociator, the atomic hydrogen is directed in a beam along the hexapole magnet by an array of close-packed glass collimating tubes 2 mm long by 50 micrometers in diameter. The strongly inhomogeneous magnetic field of the hexapole magnet provides a selection function, causing the atoms in the upper two hyperfine levels ( $F = 1$ ,  $M_F = 0, +1$ ) to move toward its axis in a focusing action while the H atoms in the lower two hyperfine levels ( $F = 1$ ,  $M_F = -1$ , and  $F = 0$ ,  $M_F = 0$ ) move radially outward and are defocused.

### Storage Bulb

The focused beam of H atoms (predominantly in the upper two hyperfine levels) emerges from the hexapole and is directed into the aperture tube of a 6-in. diameter Teflon-coated quartz storage bulb situated in a microwave cavity that is tuned to the 1420 MHz hyperfine frequency of hydrogen. Due to the high degree of elasticity in the collisions between the hydrogen atoms and the Teflon walls, the atoms are confined for up to 1 sec without deexcitation to the lower hyperfine states or recombination. The resonance linewidth of the bulb has been measured to be 0.65 Hz.

### Cavity

The microwave cavity operates in the  $TE_{011}$  mode. One distinguishing feature of the cavity design shown in Figure 8 is the use of a squashed geometry with a diameter to length ratio of 1.6. The overall height is 3.5 in. less than typical designs which use ratios equal or greater than 1.0.

A solenoid with second-order correction produces a dc magnetic field that defines a quantization axis for the sublevels so that the  $F = 1$ ,  $M_F = 0$  states are coupled to the microwave field in the cavity. When the stimulated-emission gain of the atomic transition is sufficient to overcome the storage bulb and cavity wall losses, the system can self-oscillate. (For diagnostic purposes, the magnetic field control is commandable in 256 field increments between 10  $\mu$ G and 30 mG.)

### Cavity Thermal Control

For structural and thermal integrity, a lightweight cavity with a Q in excess of 70,000 is fabricated from beryllium or quartz and frequency stabilized within 1 Hz by both the envelope thermal-control servo and the cavity-tuning control. The envelope thermal-control servo with its associated thermistor and heaters maintains the cavity temperature to within a few millidegrees of 40°C; the loop error signal is telemetered. Figure 9 shows interchangeable quartz and beryllium cavity walls that are now being studied for strength and stability.



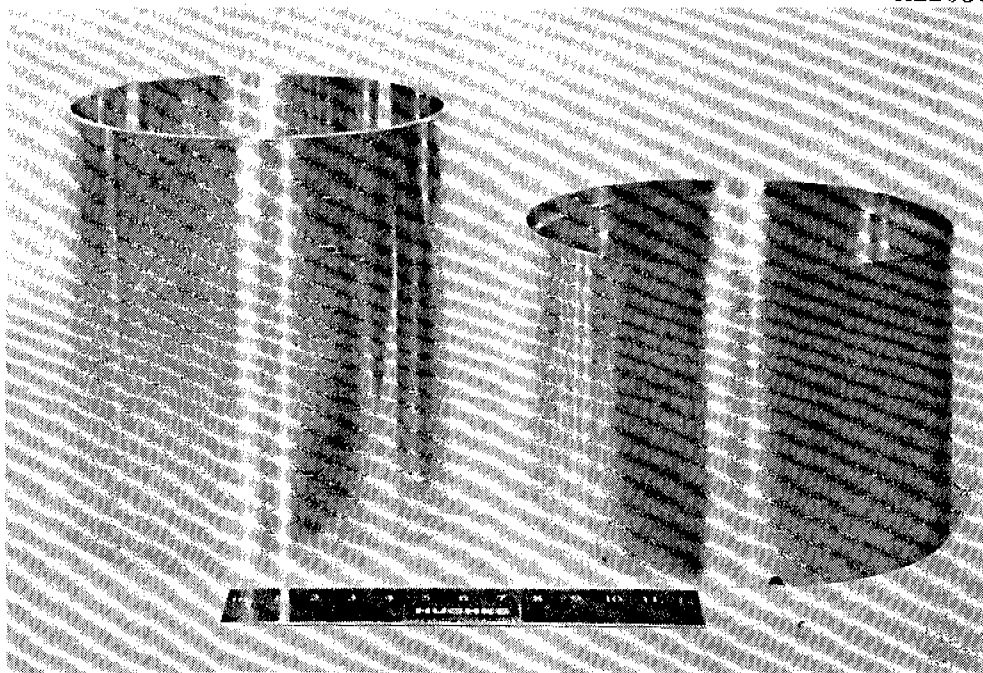
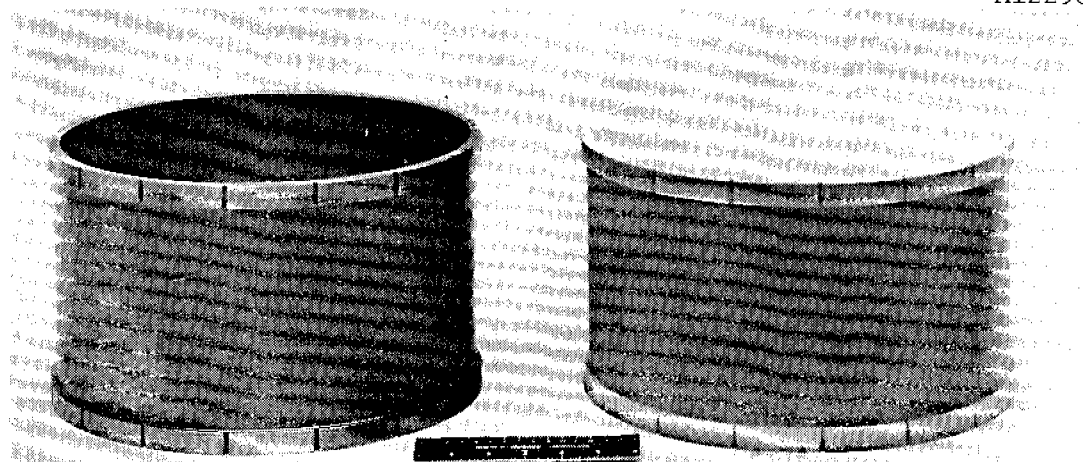

Figure 8.  $D/L = 1.6$  short cavity alongside a  $D/L = 1$  right cylindrical cavity normally used in laboratory masers.



HYMNS III INTERCHANGEABLE  
CAVITY WALLS, LEFT  
BERYLLIUM, RIGHT QUARTZ.

Figure 9. Interchangeable beryllium (left) and quartz cavities for HYMNS III testbed maser.

### Cavity Varactor Tuning

Cavity tuning is accomplished by biasing a tuning varactor made of nonmagnetic materials and located in the cavity. The varactor will tune the maser through a 50 kHz range. The varactor tuning is controlled by onboard logic or by ground command. Commandable dc offsets in the control loop allow the clock system to be compensated for long-term drift of the thermal sensor and possible mechanical detuning of the cavity during launch.

### Receiver Subsystem

The 1,420,405,751.xxxx Hz maser signal is amplified by space-qualified, low-noise, temperature-stabilized microwave amplifier and down-converted in a series of low noise mixers to 5751.xxx Hz. The phase of another 5751.xxx Hz signal, synthesized from the receiver's 5 MHz VCXO, is compared to the downconverted maser signal, and a phase error signal with a loop bandwidth of 0.1 to 10 Hz is derived to lock the frequency of the VCXO to the atomic transition. The receiver synthesizer developed for the ADM is programmable over a 2 Hz range, with each step equivalent to about 1 part in  $10^{14}$  of the maser frequency. This control enables the clock to be corrected for gravitational red shift and other systematic errors in the GPS.

### Zeeman Generator

For diagnostic purposes a Zeeman generator and beam shutter have been incorporated into the ADM maser design to detect long-term maser frequency pulling by magnetic inhomogeneities and cavity tuning errors. If required, a degaussing circuit can be activated on command to remove magnetic anomalies in the magnetic shield assembly.

### Beam Modulation

A beam shutter with a small mechanical iris is located in the hydrogen beam near the hexapole magnet, and on command can reduce the hydrogen beam flux by 50%. If the maser cavity frequency is tuned precisely to the spin-exchange-tuned frequency, the maser frequency should then be independent of the intensity of the hydrogen beam flux (i.e., beam-shutter position). Using the beam shutter, long-term frequency-pulling statistics by beam-flux modulation can be accumulated by comparing the maser frequency with another onboard clock or by clock comparison on the ground.

### Vacuum Maintenance

The spent hydrogen atoms emerging from the storage bulb are selectively pumped by an ambient-temperature sorption getter pump. A small ion pump is also used to pump hydrogen and other contaminant gases while

serving simultaneously as a high-vacuum gauge. We have conducted extensive life testing of the getter material and find it should be sufficient to pump the hydrogen supply of the maser when combined with a small ion pump to scavenge impurities. The ion-pump voltage and current will be telemetered. A space-qualified, squib-actuated vacuum vent valve may be incorporated into the maser and on command vent the maser to space to provide additional life after the ion pump and getter pump are exhausted. The data in Figure 10 indicate venting is feasible within the first year in orbit. If successful, the vent to space would allow a significant reduction in the pump weight of future masers and promises greatly increased operational life for the hydrogen maser clock system in space.

### CONCLUSIONS

Through a systematic analysis and design program encompassing all phases of hydrogen maser technology, we have designed and tested a compact hydrogen maser compatible with the constraints imposed by the NTS series spacecraft. Without sacrificing performance or operational life, a significant reduction in size was accomplished by analytical and experimental optimization of the hydrogen beam optics and microwave interaction assembly. As in our traveling-wave tube devices, the maser has been built in modular form to facilitate component interchange and standardization. During the course of the technology program we have also developed multiple vendor and in-house sources to supply critical components including quartz cavities, magnetic shields, quartz storage bulbs, and nonmagnetic varactors to assure an orderly progression into the space hardware phase of the program.

### Acknowledgment

The authors would like to acknowledge Renyold Johnson, Joseph Schmid, Hubert Erpenbach, and Dion Rettberg for their aid in the design, fabrication, and testing of the testbed masers.

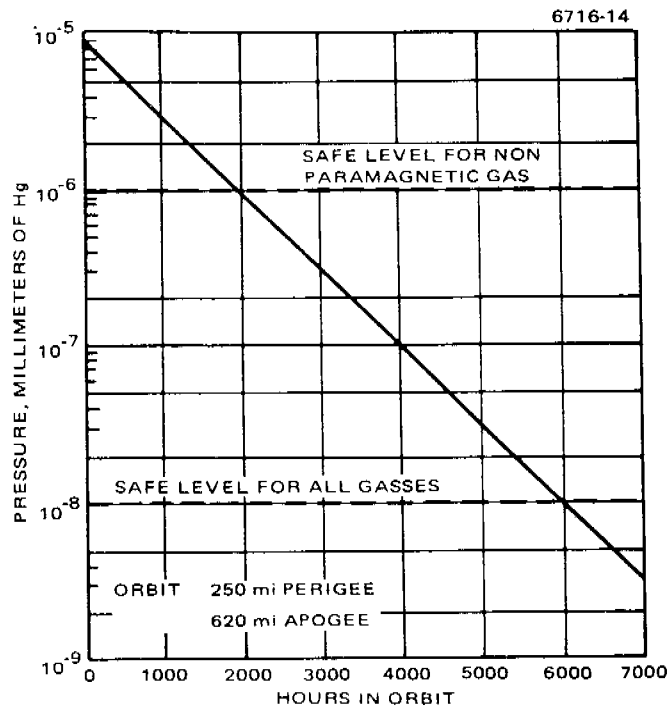

Figure 10. OGO spacecraft outgassing history.

OPERATIONAL CHARACTERISTICS OF A PROTOTYPE  
SPACEBORNE HYDROGEN MASER\*

H.T.M. Wang, A.E. Popa, W.B. Bridges,<sup>†</sup> and D. Schmelker  
Hughes Research Laboratories  
Malibu, California 90265

ABSTRACT

The operational characteristics are described of an advanced development model of a spaceborne hydrogen maser developed for the Naval Research Laboratory for possible use in their NTS-3 spacecraft. The NTS-3 is a technology satellite built as part of the Navy's support for the NAVSTAR/Global Positioning System. Size reduction is shown to not necessarily degrade maser performance.

INTRODUCTION

This paper describes our experiences in developing and operating an advanced development model (ADM) hydrogen maser testbed for the Naval Research Laboratory (NRL). The design of a space-qualifiable version based on these experiences has been described in a companion paper and will not be repeated here.

The advanced development model maser, shown in Figure 1 and termed "HYMNS III" (Hydrogen Maser for Navigational Satellites, IIIrd version) was delivered to the NRL in October 1977 and was immediately operational. Prior to delivery, some weeks of operating experience were obtained at Hughes Research Laboratories on the completed maser, and prior to this, considerable operating experience was obtained with an earlier version, HYMNS II, and a demountable testbed, HYMNS I. Separate tests were also made on various subsystems as well. For convenience and ease of reference, the operational characteristics of HYMNS III are described under the headings of its major subsystems.

Vacuum System and Pumps

For this prototype spaceborne maser, no particular attempt was made to fabricate a completely sealed, all-metallic system. Several viton O-rings as well as an indium wire seal and copper gaskets were employed.

---

\* Supported by Naval Research Laboratory under Contract N00014-75-C-1149.

† Present address: California Institute of Technology, Pasadena, CA 91125.

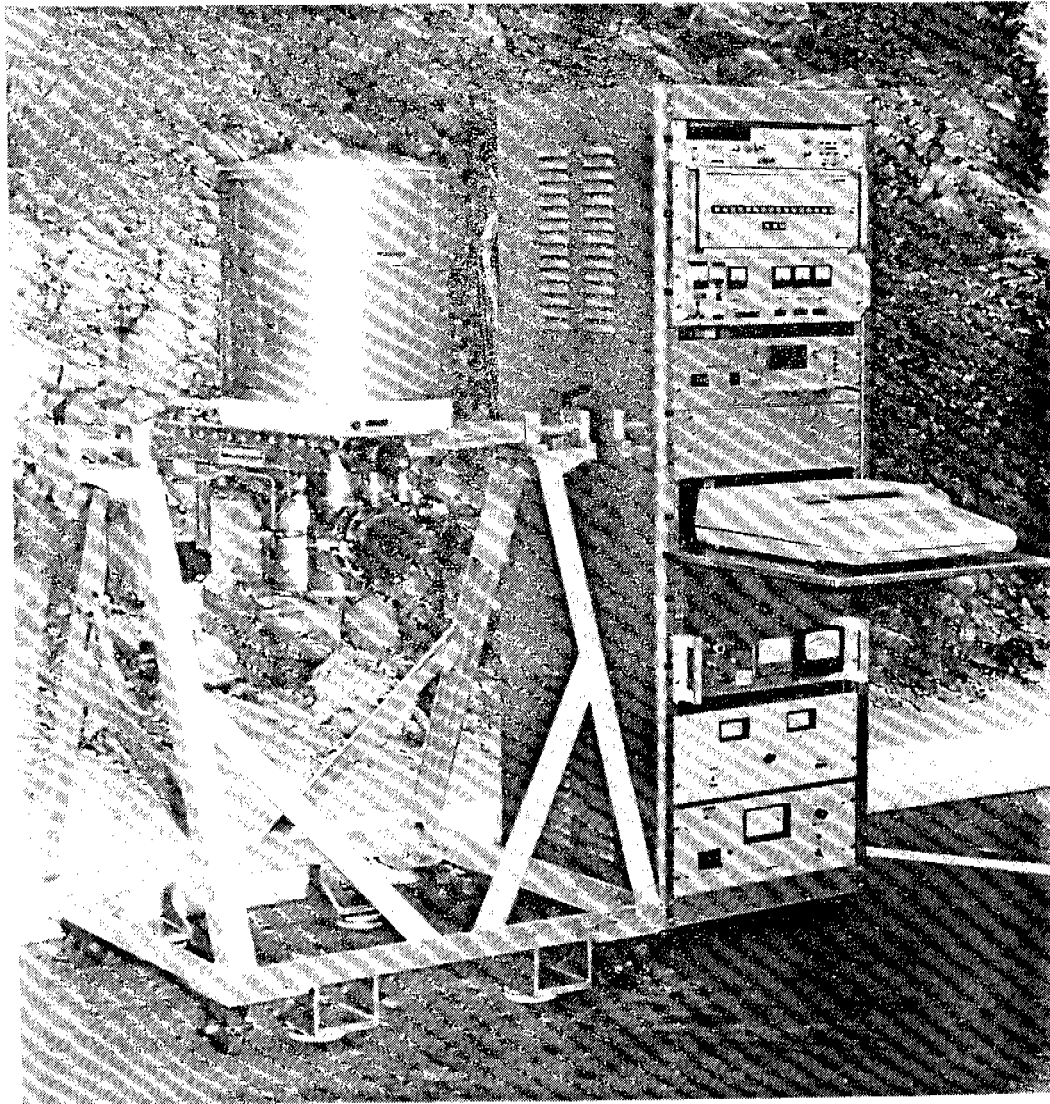

Figure 1. HYMNS III advanced development model testbed maser.

Typical residual pressure in the maser was about  $3 \times 10^{-7}$  Torr. A Varian Hi-Q ion pump with a rated speed of 30 liter/sec for hydrogen and weighing about 20 lb was selected early in the program for its compactness and relatively small stray magnetic field. With an operational hydrogen through-put of about 0.05  $\mu$ -liter/sec, the pump dissipates only about 7 W of electrical power, thus eliminating the need for cooling water. With a claimed 8000 Torr-liter hydrogen capacity, the Hi-Q pump would have an estimated life of 7.6 yr. Unfortunately, the pump requires a 7.5 kV operating voltage which is considered undesirable for use in space. Laboratory life tests at only slightly accelerated hydrogen flow rates also indicated that premature pump failure is likely to occur due to short circuits caused by detached flakes of hydrogen-saturated cathode material. As a result, alternative vacuum pumps were considered; active-metal chemical getter pumps were evaluated in several life tests and were found to be satisfactory for both the ADM and the proposed spaceborne design. As a result of these tests, a SAES getter cartridge pump was added to the HYMNS III maser. After an initial activation at high temperature, this zirconium-aluminum alloy cartridge pumps hydrogen at room temperature with no power consumption. Its specified end-of-life capacity of about 20,000 Torr-liter has been confirmed by accelerated life tests giving it an estimated life of about 12.7 yr. under normal maser operation without an ion pump. The singular disadvantage of the sorption pump is that at room temperature its pumping speed for gases other than hydrogen is very small. Thus a small supplementary ion pump will be required to scavenge impurities. For this reason the Varian Hi-Q pump was retained on HYMNS III. Even if the efficiency of the beam optical system were to remain at the level demonstrated in HYMNS III, we can confidently project a total pump subsystem weighing no more than 20 lb and consuming less than 3 W for a spaceborne maser with a five-year design life.

#### Magnetic Field and Shielding

HYMNS III employs four layers of Mu-80 cylindrical magnetic shields with domed end caps. During the development process we evaluated shields fabricated from three different materials (molypermalloys, hypernom and Mu-80) from three different suppliers. As far as can be judged from the maser performance, we have no reason to prefer one over the others. The response to degaussing is also very similar for the three materials.

To generate the small quantization field required to operate HYMNS III, a solenoid with a second-order correction is employed. Since the current through the correction coil is a constant fraction of that in the main coil, no separate optimization was required. The homogeneity of the magnetic field averaged over the maser storage bulb is such that strong maser oscillation was obtained at applied magnetic fields as low as 50  $\mu$ G. In fact, steady maser oscillation was observed at applied

fields as low as 20  $\mu\text{G}$ , at which point residual fields from the shields and stray fields from the ac heaters of the temperature control system introduce significant perturbations.

#### Thermal Control System

Temperature-control resistive heater windings in HYMNS III employ alternating currents. Since perfect bifilar windings are difficult to obtain, perturbations to the maser oscillation frequency caused by magnetic field fluctuations arising from direct-current heater current variations are substantially reduced by using ac. This makes a significant contribution to the excellent operational characteristics of the maser at very low applied magnetic fields. Four separate heaters and control circuits are employed. Glass bead thermistors with nominal resistance of 50  $\text{k}\Omega$  at 25°C are used as sensors.

#### Atomic Hydrogen Source and Beam Optics

Atomic hydrogen is obtained by rf discharge in a 2-in. diam pyrex bulb. Delays in material delivery prevented the incorporation of a novel metal-ceramic dissociator in the delivered HYMNS III maser. However, a prototype metal-ceramic dissociator had been bench-tested separately and was found to be at least as efficient in hydrogen atom production. The metal-ceramic structure provides significantly improved mechanical strength and eliminates any possibility of breakage in the feed lines supplying hydrogen. Dissociator pressure regulation is obtained by a thermally regulated palladium-silver alloy valve in the form of a thin-wall tubing which formed part of the electrical circuit. Typical power consumption to heat this valve was about 0.5 W with a control constant of about 30 sec. The rf power supply utilized a linear power amplifier driven by a crystal-controlled oscillator at about 150 MHz. For normal maser operation, a sustaining rf power of about 3 to 5 W is sufficient. It is necessary to momentarily raise the rf level to about 10 W to ignite the discharge. The low sustaining drive level is desirable to extend the life of the dissociator. Moreover, higher rf levels do not give correspondingly higher atom production, as proved by actual measurement using thermal wire-bridge detectors and optical photometers in a separate test-stand evaluation of dissociator performance.

A hexapole magnet (FTS model HM-2) is used for state selection. Since the spacing between the hexapole magnet and the storage bulb aperture is only 8 in., a beam stop is necessary to block the unselected atoms traveling along the axis of the magnet. However, the efficiency of the system is such that under normal operation conditions, a total hydrogen throughput of less than 0.05 micron-liter/sec is sufficient.

For spin-exchange tuning, the flux is modulated by an electrically operated beam shutter with a beam attenuation of about 50% rather than by changing the flow or rf drive to the dissociator bulb. Since the



shutter operates independently of the dissociator, the response is essentially instantaneous. More important, the dissociator operating parameters remain constant, and the chances for irreversible damage to the dissociator by pressure or drive modulation are greatly reduced.

#### Microwave Cavity

The TE<sub>011</sub> microwave cavity is fabricated from a precision-machined satin-fused silica cylinder with aluminum end plates. The inside dimensions are 12 in. diam by 7.4 in. long, giving a length reduction of about 3.5 in. compared to the right cylindrical cavity. It is equipped with a linear varactor tuning loop and a single 50  $\Omega$  output coupling line. A high-conductivity silver coating gives the cavity a measured loaded Q of 65,000 with a coupling coefficient of 0.21. This is about 98% of the theoretical maximum. The resonant frequency of the cavity when loaded with the 6-in. maser storage bulb has a measured temperature coefficient of 1.3 kHz/ $^{\circ}$ C.

To prevent the long-term drift in the cavity resonant frequency from limiting the maser stability performance, an electronic cavity frequency monitoring and control system was designed. The system operated by coherently detecting switched test signals at frequencies symmetrically situated with respect to the spin-exchange-tuned cavity frequency, and offset from it by about half the cavity resonant width. The error voltage thus derived is used to bias the varactor tuning loop. A prototype tuning system was tested on the HYMNS II maser, however, the use of a single-line cavity coupling system resulted in poor signal-to-noise ratio and the system has not been implemented on HYMNS III. In the future, by using a two-port cavity coupling system, we expect significant improvement in signal-to-noise, and the system should prove to be a valuable diagnostic tool in addition to the electronically stabilizing the cavity resonant frequency.

#### Maser Storage Bulb

The storage bulb is a 6-in. diam blown fused quartz sphere. It is coated with FEP-120 teflon by standard techniques. Although the spherical bulb geometry was selected for ease of fabrication, the filling factor in the D/L = 1.6 microwave cavity is very nearly the same as the optimal value of 0.37 for an ellipsoidal bulb. The geometrical storage time is designed to be 1.25 sec. Although no systematic measurement and analysis of linewidth contributions have been made yet, the full maser transition linewidth under normal operating conditions was measured as 0.75 Hz, corresponding to a line Q of  $1.9 \times 10^9$ . This value compares very favorably with those for full-size laboratory masers.

## Maser Receiver

The triple-conversion maser receiver provides standard outputs at 5 and 10 MHz, phase-locked to the maser. It is equipped with a synthesizer at 5751.xxxx Hz and is adjustable in steps of 1 part in  $10^{14}$  of the maser frequency. For tuning and diagnostic purposes, the receiver can be operated open-loop with an external 5 MHz reference signal. Down-converted 5.75 kHz maser signal as well as low-frequency beat notes are available for measurements by a counter.

## Spin-Exchange Tuning and Stability Measurement

The automated operating features of HYMNS III represent a significant advance in maser design. The procedures generally encountered in maser operations can be carried out simply by depressing appropriate control buttons. An operator with detailed knowledge of maser theory is not required to carry out what used to be a long, tedious and intricate spin-exchange tuning process. In fact, when the spin-exchange tuning program is executed, the process continues automatically until specified precision is achieved, or it can be terminated at any time desired. As mentioned earlier, since a beam shutter is employed for flux modulation, long waiting periods for the dissociator to stabilize are unnecessary, and a significant savings in tune-up time is obtained.

The system controller is a Hewlett-Packard Model 9825A programmable calculator. Programs for functions such as initial setup, spin-exchange tuning, stability measurement, adjustments of applied magnetic field, varactor bias and receiver synthesizer, etc. are stored in the calculator memory and are instantly accessible. As an illustration, a typical spin-exchange tuning run is shown in Figure 2. When the program is called, interactive messages are displayed. After the desired precision expressed by the varactor bias tolerance, the low-high flux pulling, and the number of periods averaged and counter readings to produce a frequency sample are specified, the program runs automatically. The data were taken with a VLG-10 maser as an external reference, and the tuning process was completed in less than 35 min. The specified  $5 \times 10^{-3}$  V varactor bias tolerance corresponds to a possible tuning error of 2 parts in  $10^{13}$ .

Preliminary stability data taken by NRL which compares the testbed with a VLG-10 are shown in Figure 3. These data, taken with the exploratory development model receiver can be improved by a factor of 3 when the maser is used with our HYMNS II laboratory breadboard receiver. We plan to continue refinement of the receiver electronics as we proceed in our technology studies.

START SPIN EXCH TUNING	END SPIN EXCH TUNING
AUTO TUNING	VARB: 5.43789
Period Avged	LoBm
1e5	5751.672737
Readings/Set	5751.672539
5	5751.672407
Pull Tol	5751.673091
1.4e-5	5751.672638
VARB Tol	AvF: 5751.672683
5e-3	+/- 0.000259
VARB: 5.18292	HiBm
LoBm	5751.672463
5751.655968	5751.672929
5751.655866	5751.672506
5751.655833	5751.672741
5751.655598	5751.672608
5751.655925	AvF: 5751.672649
AvF: 5751.655838	+/- 0.000190
+/- 0.000144	LoBm
HiBm	5751.672774
5751.653649	5751.672605
5751.653583	5751.672509
5751.653553	5751.672506
5751.653676	5751.672638
5751.653653	AvF: 5751.672606
AvF: 5751.653623	+/- 0.000110
+/- 0.000052	Pull= 0.000005
LoBm	+/- 0.000236
5751.655866	SETVB 5.437327
5751.655896	+/- 0.026795
5751.656031	Wd Av 5.43805
5751.655790	+/- 0.00474
5751.655833	Cov SETd at VB =
AvF: 5751.655883	5.43805
+/- 0.000092	
Full+ -0.002238	
+/- 0.000100	
VAR 5.68260	

Figure 2. Frequency comparison of the Hughes testbed maser and the SAO VLG-10 maser using the XDM receiver in the Spin Exchange Tuning mode. Only the final 10 digits are shown.

## CONCLUSIONS

The operational characteristics of HYMNS III along with extensive life-test data obtained during our technology program lead us to the conclusion that a reduced size, long-lived spaceborne maser can be space qualified using existing technology. We also conclude that the maser can be made compatible with the size, weight, and power constraints of the NTS-3 spacecraft without any sacrifice in the superior stability performance exhibited by laboratory devices.

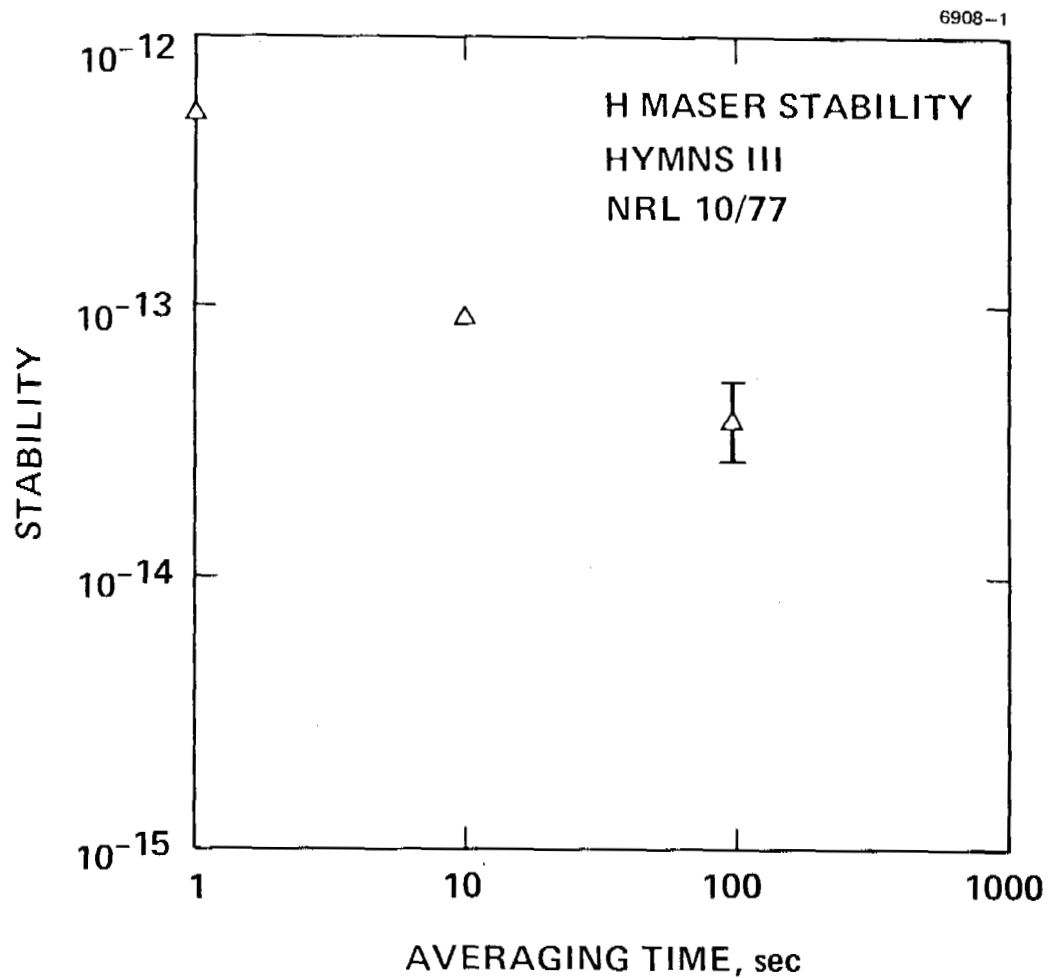

Figure 3. Preliminary stability data.

## QUESTIONS AND ANSWERS

MR. WOLFGANG BAER, Ford Aerospace:

What is the final weight that you expect on the NTS-3 satellite? Where do you expect weight and size to go on the hydrogen maser designs?

MR. WANG:

I guess the weight and size, as given in the previous talk, depends on the spacecraft. Tentatively we are shooting for 100 pounds and consuming less than 100 watts with a 15-inch diameter and less than 30-inches long. But that is very tentative. Roger Easton or some people from NRL will be able to define those parameters better for you.

MR. BAER:

Do you have any feeling for where you might go in terms of weight and size in the maser development?

MR. WANG:

I feel that we can probably reduce the length and diameter by another inch or two on this active maser, but probably not much more. The weight, of course, depends on the polymer you finally select as well as the magnetic shield. Those are the heaviest components.

DR. ROBERT VESSOT, Smithsonian Astrophysical Observatory:

To give a little perspective on this, the one we flew weighed 88 pounds. It was 19-inches in diameter and about 24 inches tall. With a TE 111 cavity, allowing the same spacing between 4 layers of magnetic shields, you could make a maser fasten in a 12-inch diameter tube and be on the order of, I think, 20 inches in length. The cavity is a valid concept because it does oscillate and it will work.

In relation to the cartridge, we found that we could run the cartridge well over a year and it didn't saturate and it was a marvelous getter. But we just needed a very, very small ion pump to take care of the stuff that wasn't hydrogen, as I think you have also seen. But the function of the ion pump was also to take apart molecules that contained hydrogen as a dissociator.

I really think the future of hydrogen pumping for the maser is in the cartridge. I feel that we are contributing noise to our system by having a glow discharge. Even if it is in the milliamps, that is just not a wholesome thing to have, plus the fact we have these monstrous magnets in the vac ions, the weight, the shield, and all the rest of it. I really feel that the way to go is in the cartridge.

MR. WOLF:

I agree.