

NEW POSSIBILITIES FOR TIME AND STANDARD FREQUENCY
DISSEMINATION OVER TV NETWORKS

Bogosav Ž. Kovačević, Faculty of Electronic Engineering,
University of Niš, Niš, Yugoslavia

ABSTRACT

This paper describes the principles of a new Time and TV Synchro System developed and currently in experimental use at the TV Studio Belgrade in Yugoslavia. This Time and TV Synchro System secures the time of coincidence every second by definition for all programs originating within the TV studio Belgrade. The incorporation of the digital TV frame synchronizer in the video path enables its application with the same quality of dissemination of time and standard frequency signals, regardless of the place from which the particular program originates. The system can also be applied in connection with TV broadcasting over geostationary TV satellites.

INTRODUCTION

Recent research in many countries has resulted in a number of conclusions which indicate new possibilities for using the existing TV networks for dissemination of time and standard frequency signals. The advantage of such a system in many applications is obvious, and it involves a relatively small investment of the capital for the adaptation of the existing TV network. The ordinary TV receiver can easily be adapted for the purpose of a user at a small cost. Such an adapted TV receiver is very inexpensive compared to many time and standard frequency facilities it offers to its user in the actual exploitation.

Practical realization of the system for time and standard frequency dissemination over the TV networks necessitates the consideration and solution of many technical programs, such as:

1. Determination and maintenance of the time signals at the TV transmitting point in relation to the time scale (UTC);

2. The precise knowledge of the propagation time from the transmitter to the receiver and the maintenance of that propagation time to a fixed (constant) value as closely as possible;
3. Problems associated with a given particular TV system (NTSC, PAL, SECAM, etc.);
4. Problems associated with the instantaneous TV picture formation mode within the given TV system (live transmission from a camera, VTR program, film presentation program, other TV network program, etc.).

The purpose of this paper is to describe in principle a new Time and TV Synchro System developed and currently in experimental use at the TV studio Belgrade in Yugoslavia. This Time and TV Synchro System secures the Time of Coincidence every second in the transmission of the second pulses.

TIME AND TV SYNCHRO SYSTEM

The TV studio Belgrade, Yugoslavia began over four years ago the experimental transmission of time and standard frequency signals by using the so-called active TV system (Kovacevic 1973 and 1974, Kovacevic et al. 1976; also cf. Howe 1972). In this system, second pulses, standard frequency and the coded time of day are injected into the 19th and the 332nd line of the video signal, v. Figure 1. On the other hand, the time signals, standard frequency and the TV sync pulses are all derived from the cesium clock which itself is located within the TV studio premises.

At this point we define and understand by the complete or full synchronization for the purposes of this system such a technical realization of synchronization, in which the second pulses appear every second at precisely the same point or place of a single selected line of the TV picture. Since the second pulses must appear at the same place of the selected line in accordance with the requirement of the full synchronization, that means that the time information must be injected only once within a single complete frame. This obviously necessitates that the vertical interval TV sync pulses be referred and adjusted in accordance with the second pulses from the same standard clock. This can easily be realized in the case of all European TV systems, since one second, the period of the second pulses, is an even integral multiple of the field period of 20 ms. On the other hand, in the case of the US TV system, the nominal field period is 16 and 2/3 ms, which is not contained in one second as an even integer. For the TV systems with 60 Hz as the fundamental frequency, the Time of Coincidence is 16 min. and 41 sec. (CCIR 7/26E 1973, Davis 1975), or thereabouts

depending on the actual field frequency in use. In that respect, it should be mentioned that if there is no synchronism between the TV frame frequencies and the time signals, the upper limit of ambiguity of the time information transmission is 40 ms for the 50 Hz TV systems (Europe), or 33 and 1/3 ms for the 60 Hz TV systems in the USA and elsewhere, as the consequence of the waiting for the selected line into which time information is injected. Possibilities of various TV systems for time and standard frequency dissemination are shown in Table 1.

COLOR STANDARD	Passive		Active		Nominal field frequency
	Subcarrier frequency f_{sc}	Field frequency f_v	Second pulses	1 MHz Burst	
NTSC	yes	yes	no	yes	60 Hz
PAL	yes	yes	yes	yes	50 Hz
SEKAM	no	yes	yes	yes	50 Hz

TABLE 1

With reference to Figure 2, which shows in principle the Time and TV Synchro System realized at the TV studio Belgrade, the time of coincidence is realized every second in the case of the PAL 50 Hz TV system in use at the TV Belgrade. It is clear from Figure 2 that the synchronization between the clock and the Master TV Sync Generator is required not only with respect to the frequency, but also with respect to the phase. Figure 2, which shows in principle the realized Time and TV Synchro System at the TV studio Belgrade, is self-explanatory to a large extent. Note that the coincidence circuit resets the selected line number 19, whenever the synchronization has been interrupted for any reason, provided of course that the circuitry remains operable.

Figure 3 shows how the described Time and TV Synchro System was incorporated within the normal TV circuit (video path), with some obvious simplifications of the principle circuit diagram as shown in Figure 2.

Figure 4 shows the adapted TV receiver with all the standard signals at the disposal of the user at the receiving point, which are: 1 pps UTC (YU) with minute and hour markers, 1 MHz, the subcarrier of 4.43 MHz, the line frequency of 15,625 Hz, the field frequency of 50 Hz, and the frame frequency of 25 Hz. An ordinary commercially manufactured TV receiver has been adapted. The 13 digits, which appear on the TV screen as shown in Figure 4, are obtained through the appropriate blanking of the video signal. The accuracy code digit, which is encoded in the time of day pulse train (v. Figure 1), indicates the location of the source of the actual video signal, since the realized accuracy, i.e., precision, of the time and standard frequency transmission depends on that location. The difference between the UTC and the local time (clock) (UTC - LOCAL TIME in Figure 4) is displayed on the screen as the last six digits. The difference is given in the appropriate units which can be chosen by the operator in microseconds or tens of nanoseconds.

PRACTICAL TV BROADCASTS AND TIME OF COINCIDENCE

As already stated, the synchronization between the time signals and the TV picture is achieved by the Master Sync Generator (v. Figure 2 and 3), and forms as such a part of the entire developed system. The time of coincidence is fully assured in this system whenever the TV program originates within the system itself by definition. During the exploitation of the developed system at the TV studio Belgrade it was noticed, which was theoretically anticipated, that the time of coincidence is subject to random fluctuations in the case of the VTR programs. Also by definition the Time of Coincidence cannot be achieved when an external program is being aired. The external program is normally not locked on the same Master Sync generator, and there is also some random fluctuation of the propagation time of that external program from a distant studio. Thus, the accuracy is not the same all the time, and it depends on the program itself and the means used for its realization. The best quality is assured and is achieved practically when a local live fully electronic video signal is transmitted (live camera within the system). For instance, during local VTR broadcasting, the random fluctuation (jitter) of the sync pulses and the standard frequency of 1 MHz, including the second pulses, is normally 3 to 10 times greater compared to similar fluctuation during the live fully electronic camera programs.

Considering the fact that over 80% of the TV programs are often obtained from VTR's and other networks, as is the case for the TV studio Belgrade and most TV stations all over the world, then there remains only 10 to 15% of broadcast time for telecine films and live camera programs which offer the optimal conditions for time and standard frequency dissemination. This practically means that there

are only two to three intervals longer than 1,000 seconds for the optimal time and standard frequency dissemination, which may not be sufficient for the practical purposes of the users.

This disadvantage can be successfully overcome by utilizing a digital TV frame store synchronizer in the video path and its incorporation in the Time and TV Synchrosystem as previously outlined (Kano et al. 1974 and Butler 1974). Figure 5 shows the simplified block diagram of the frame synchronizer. The basic characteristics of this scheme is that it can store in the digital form one entire TV frame. The digital recording-writing is accomplished by the application of the parameters of the original composite sync pulses. The readout is accomplished by the application of the Master Sync Generator (MSG). Thus, since the MSG itself is locked within the Time and TV Synchro System, the Time of Coincidence is realized every second with the accompanying optimal time and standard frequency dissemination for the entire duration of such a program, regardless of the place from which that original video signal is transmitted. Figure 6 shows how the frame synchronizer is incorporated in the TV video path. It should also be mentioned that this system normally introduces a significant improvement of the quality in the video signal processing.

During the last three days of the 1976 Montreal Olympic Games, the receiving and converting service for the European TV viewers was secured only through the Yugoslav TV facilities. The above described system was used during that 1976 Montreal Olympic Games coverage for Europe, but the digital memory from the Standard Converter (525/60-NTSC into 625/50-PAL) was read by using the appropriate signals from the Master Synchro Generator of the Time and TV Synchro System as shown earlier in Figure 2. To the best of this author's knowledge, this system has been used for the first time in this instance for the TV coverage of a program over a wider geographic area. Detailed measurements during that transmission have clearly proved that the quality of the time and standard frequency dissemination through the TV network to the receiving point is the same as the quality which is normally achieved during the live camera programs, although the program originated about 7,000 km (geographic distance) from the Yugoslav Ground TV Station to Satellite TV facility. Of course, the time and standard frequency signals were injected at the TV studio Belgrade during all that coverage for Eurovision.

TV SATELLITES AND TIME AND TV SYNCHRO SYSTEM

According to the planned distribution of TV satellites for Europe, each European country has already been allocated at least one geostationary TV satellite, which will cover only the territory of that country (Geneva 1977, World Administrative Radio Conference for the Satellite Broadcasting). The above described Time and TV Synchro System can be

applied to TV transmission over TV broadcasting satellites. The formation and injection of the time and standard frequency signals can be performed either at the TV studio, or at the TV ground transmitting facility.

The variations of the propagation time between the Earth and the geostationary satellite are considerable and of the order of milliseconds. These variations are the consequences of well-known causes and they are relatively slow during the 24 hour period (Spilker 1977). These variations can cause degradation of the quality of time and standard frequency dissemination during TV satellite broadcasting, as compared to the quality obtainable with the ground TV system. However, these variations can be in principle corrected within the described Time and TV Synchro System, and the Time of Coincidence can be achieved every second for the entire duration of such a program. This correction consists of delaying or advancing the second pulses with reference to the average propagation time, so that the received second pulses at the TV receiving ground point (v. Figure 8) coincide with the UTC (YU), while the formation of the TV sync pulses are coordinated with and referred to the advanced second pulses. Note that the second pulses are all the time advanced for the total propagation time during such a transmission, which is evident from Figure 8. The correction of these variations can be improved over a given wide geographic area by averaging delay times measured at a number of the fixed ground receiving points which are connected to the center via fixed ground facilities.

The Yugoslav TV system has no geostationary TV satellite of its own at the moment, and for that reason some limited experiments have been performed by utilizing the Yugoslav ground facilities and the INTELSAT-IVA telecommunications satellite. The results of those measurements and analytical comparison with the theoretically introduced corrections have proved that it is possible to realize the time and standard frequency dissemination TV system covering the entire territory of Yugoslavia, whose second pulses will never deviate from any receiving point for more than 20 microseconds.

CONCLUSIONS

On the basis of the extensive experimental data, the following conclusions have been obtained by this author:

1. It is possible to realize complete synchronization between the TV picture and the second pulses for those TV systems for which the field frequency is 50 Hz. This practically means that the second pulses appear at precisely the same place of a selected line of the TV picture. Therefore, the Time of Coincidence for such a system is every second, by definition.

2. The utilization of the digital frame synchronizer in the video signal processing offers the possibility to achieve the Time of Coincidence every second for every program in the case of all 50 Hz TV systems with the same quality of dissemination of the time and standard frequency signals within the wide area TV system.
3. The described Time and TV Synchro System also offers the possibility for the correction of the propagation time variations encountered during the TV broadcasting over the geostationary TV satellite with the accompanying Time of Coincidence every second, and without any interference with the video signals.

REFERENCES

- Howe, D. 1972 "Nationwide precise time and frequency distribution utilizing an active code within network television Broadcasts", *IEEE Trans. Instr. Meas.*, IM-21, 1972
- Kano, K. 1974 "Television Frame Synchronizer", Reprinted by SMPTE
et al. "Digital Video", pp. 74-78, New York, 1977
- Kovačević, B. 1973 "The first experimental results of time and frequency dissemination via TV network" - JUKEM - Proc. 1973, XXV/18 Belgrade (in Serbo-croat).
- 1974 "Time and its Measurements" Academy of Art and Science, 1974, Vol. 23, Belgrade (in French)
- 1976 "TV System and Time Synchronization" IBC-London 1976
- Palić, N. 1972 "Experimental High Precision System for Transmitting Time Units and Frequency Over Television Channels", *Izmeritel'naya Teknika*, No. 1, pp. 34 - 37, 1972.
- Spilker, J. 1977 "Digital Communications by Satellite", Prentice-Hall, 1977.

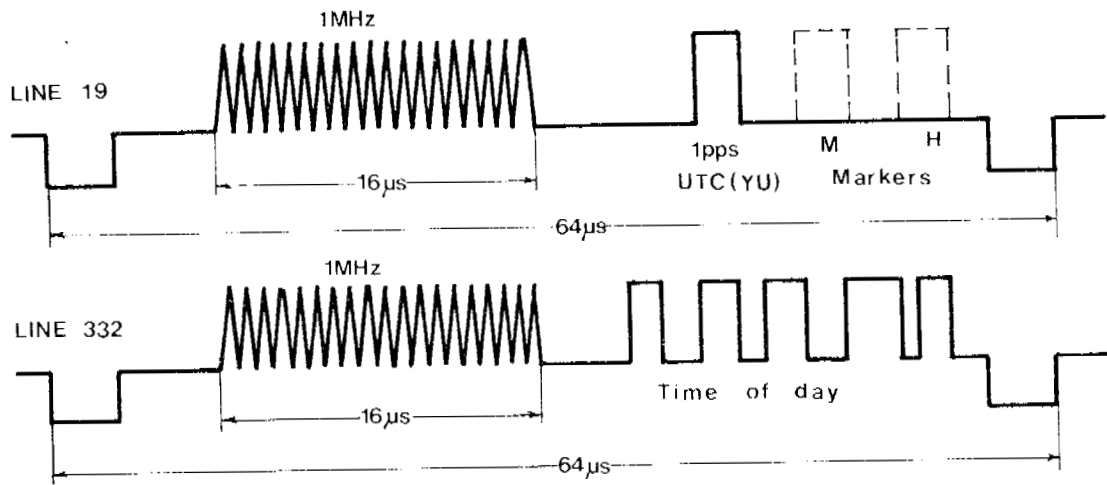

Fig. 1

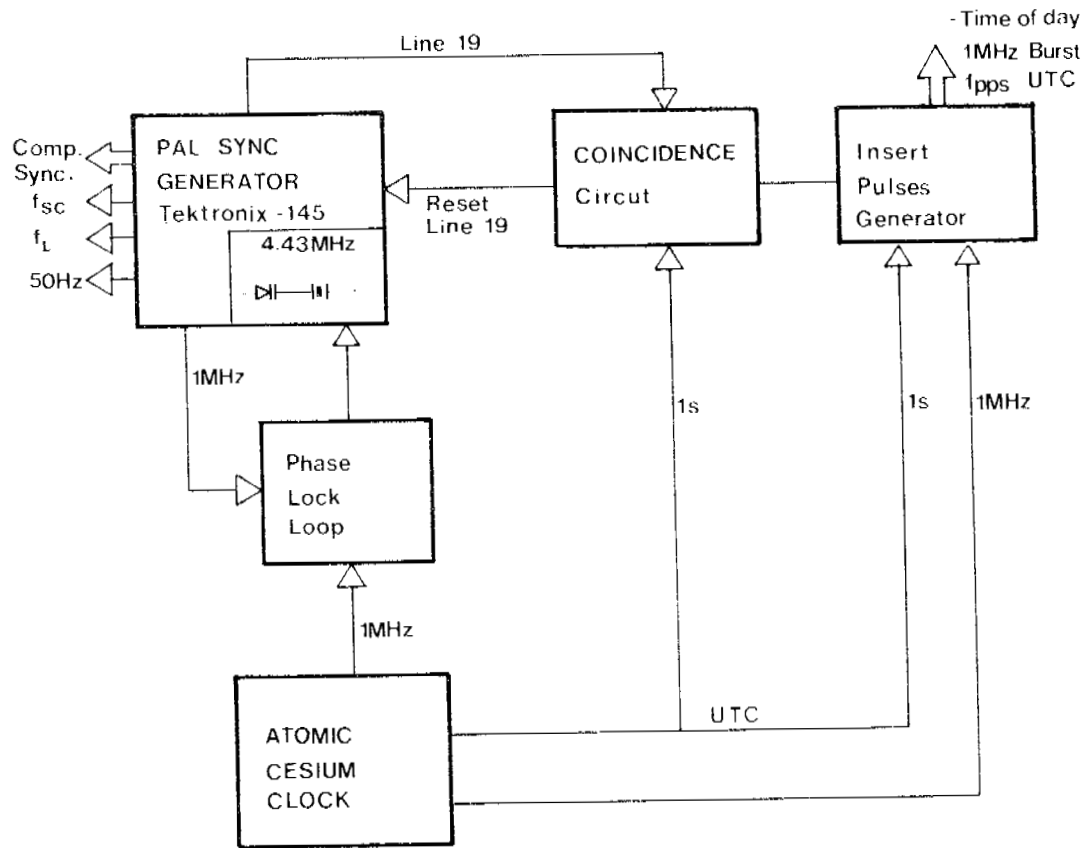

Fig. 2 TIME and TV Synchro System

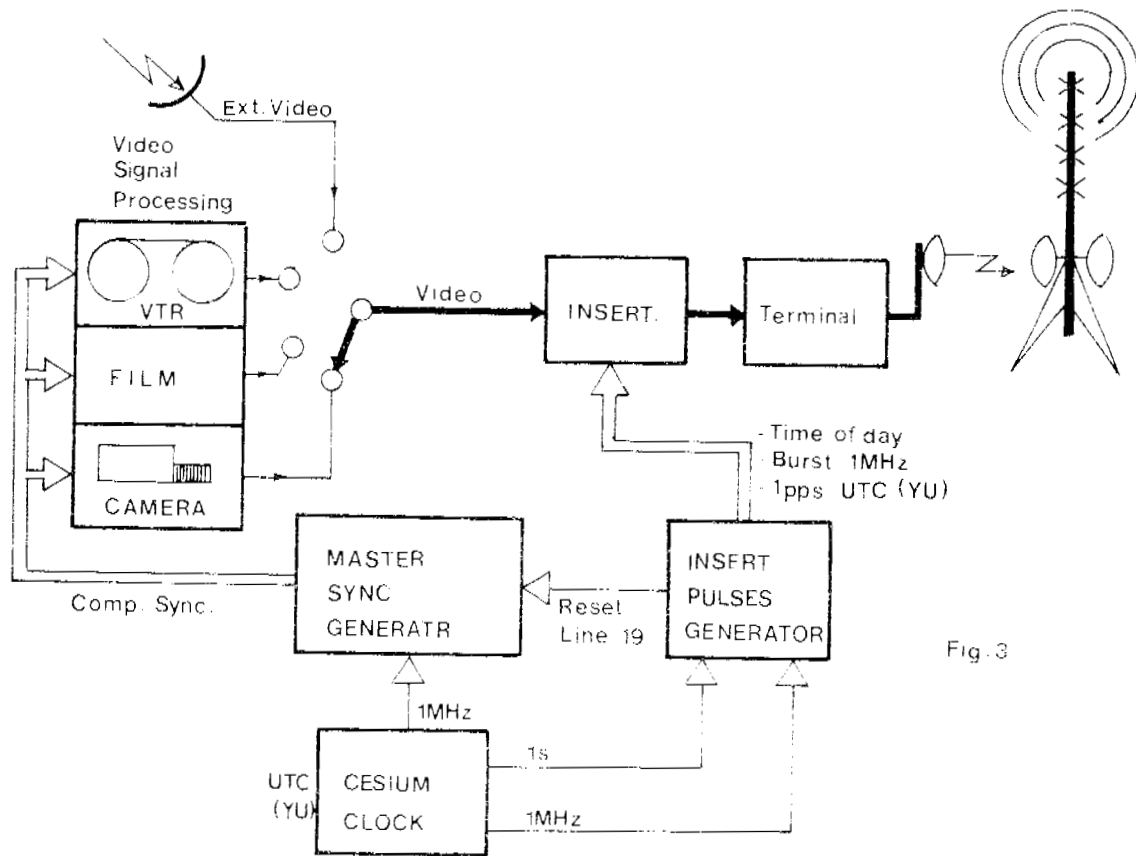

Fig. 3

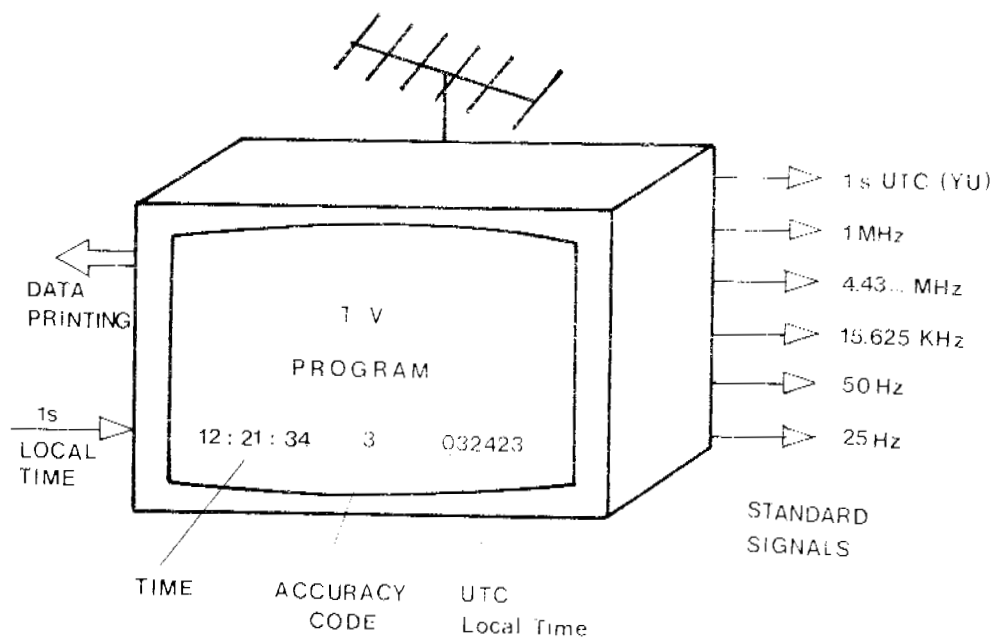

Fig. 4

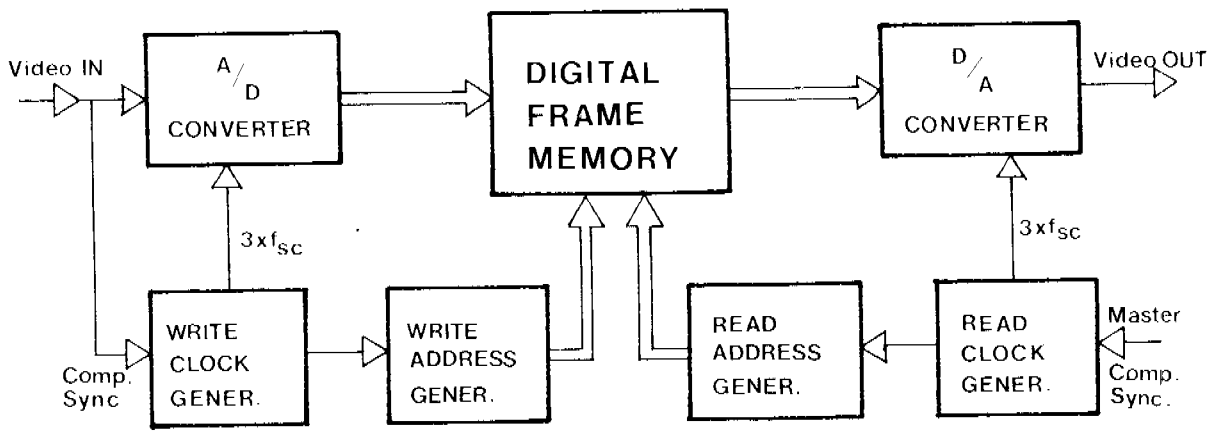

Fig. 5 - Frame Store Synchronizer

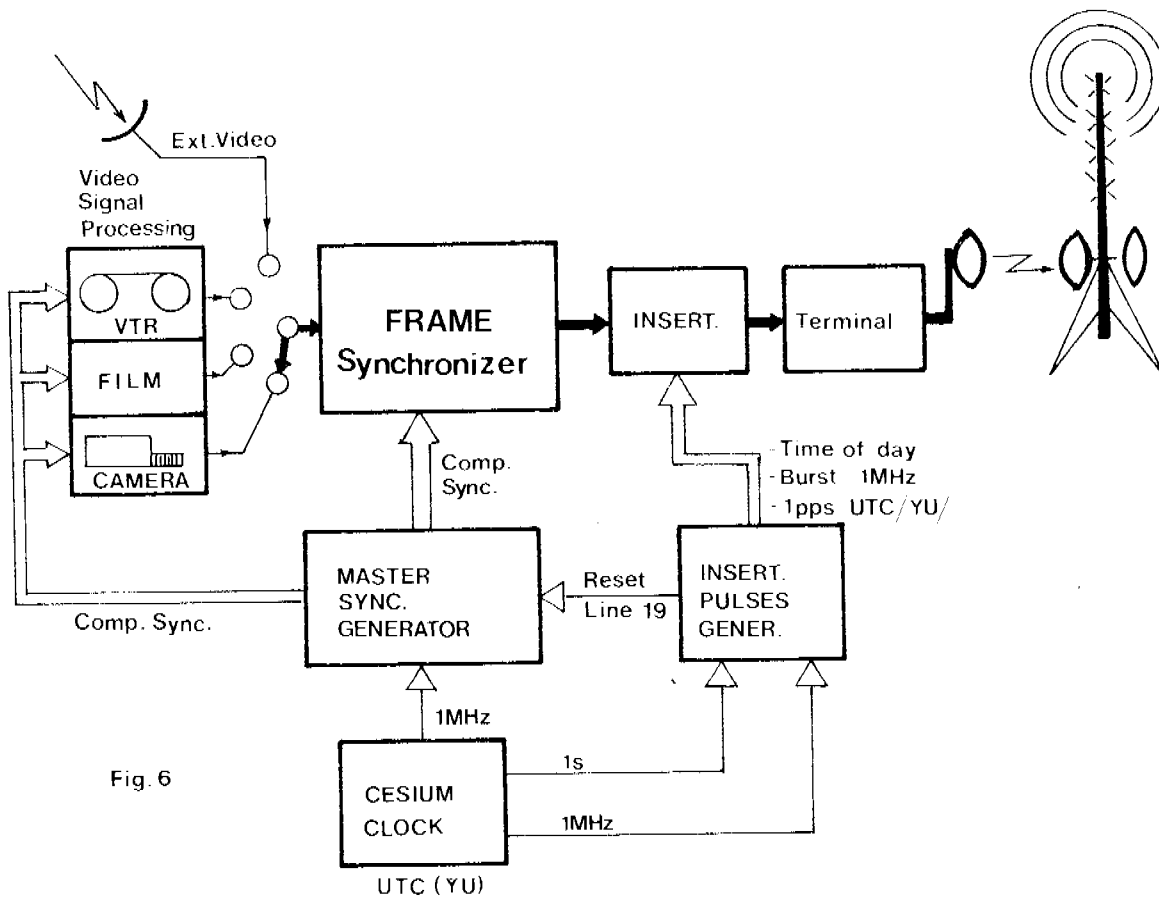

Fig. 6

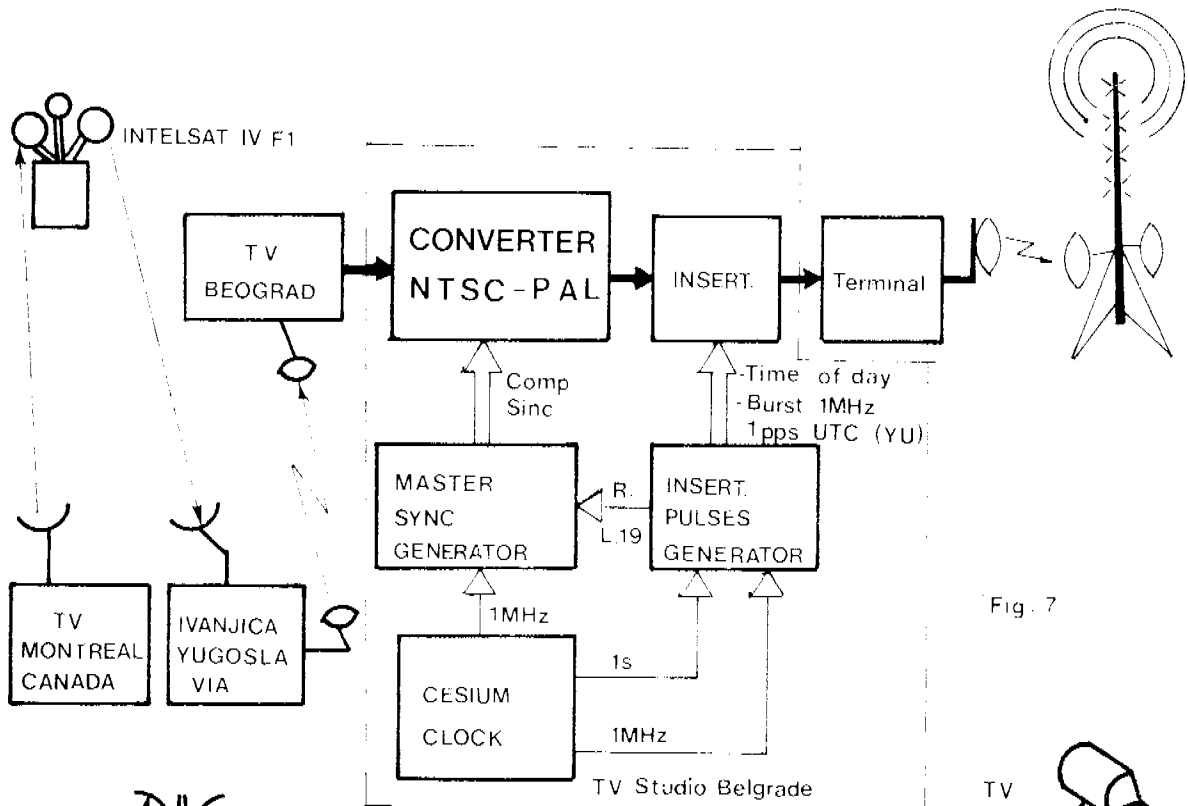

Fig. 7

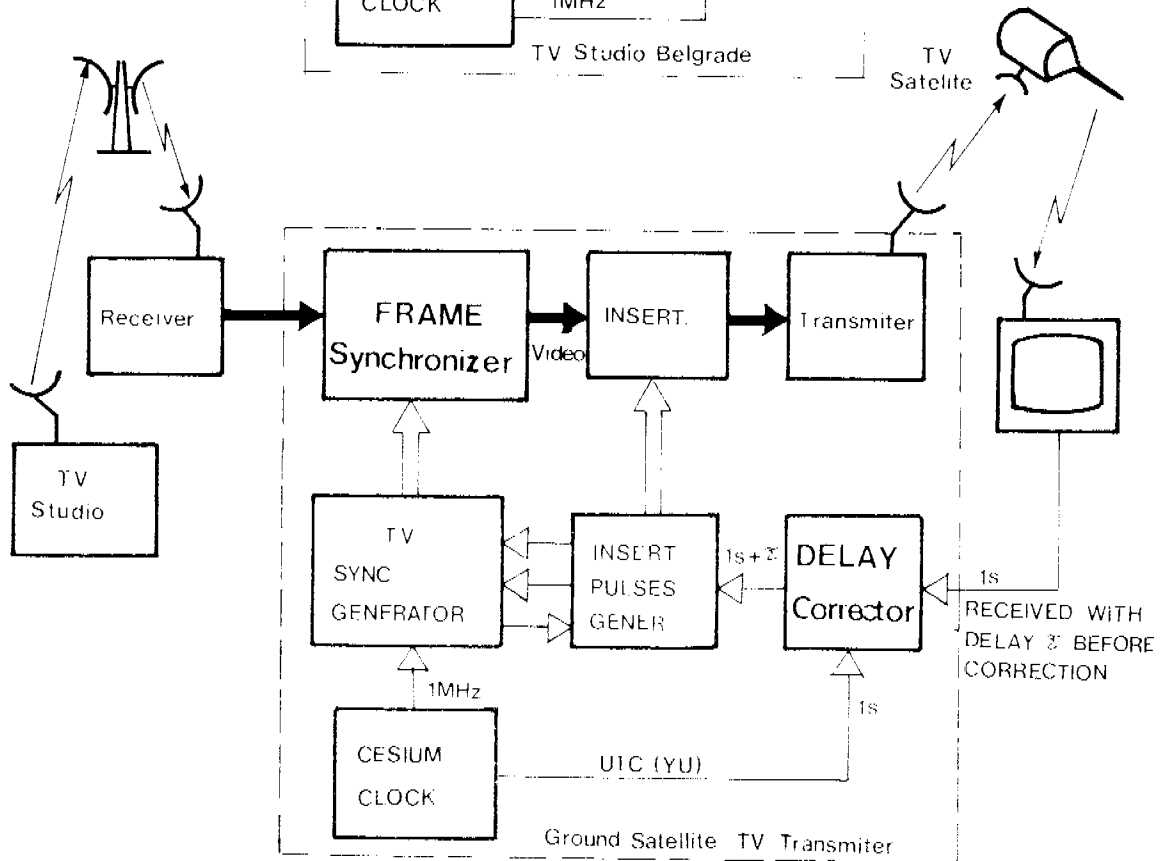

Fig 8 TIME DISSEMINATION VIA TV SATELLITE