

A TIME CODE FROM NOAA'S GEOSTATIONARY OPERATIONAL  
ENVIRONMENTAL SATELLITES

D. W. Hanson, J. V. Cateora, and D. D. Davis National Bureau of  
Standards, Boulder, Colorado

ABSTRACT

In support of the environmental data collection by the National Oceanic and Atmospheric Administration's (NOAA's) Geostationary Operational Environmental satellites (GOES), a time code has been incorporated by the National Bureau of Standards (NBS) into an interrogation message from these satellites. This message is directed to data-collection platforms engaged in seismic, Tsunami, hydromet and other related monitoring activities. The NBS has developed this time-code system to serve environmental data users who require only a few tenths of a second accuracy as well as those who need a more accurate time reference.

The time code is available continuously from two geostationary satellites and provides a coverage of the Atlantic and Pacific Ocean Basins as well as the North and South American Continents. The time code includes the necessary information to compensate for free-space propagation delays between the master clock located at Wallops Island, Virginia, and the user. Preliminary results indicate a timing resolution of 10  $\mu$ s. The accuracy is very much dependent upon the quality of orbital information supplied to NBS by NOAA. This is presently being evaluated.

The time-code system is supported by atomic clocks maintained at Wallops Island, Virginia, the point of origin for all signals to be sent through the satellites. A data-logging system monitors three television networks and Loran-C to provide a comparison link between the Wallops Island clocks and reference standards at the NBS.

A microprocessor "smart" clock has been developed for the user that automatically corrects for path and equipment delays and places its recovered time in synchronism with Coordinated Universal Time (UTC) generated by NBS. This clock and associated recovery equipment will also be discussed in the presentation.

## INTRODUCTION

A time code has been added by the National Bureau of Standards (NBS) into a communications channel between the National Oceanic and Atmospheric Administration's (NOAA's Geostationary Operational Environmental Satellites (GOES) and remote environmental data-gathering platforms. The time code is continuously available throughout the entire Western Hemisphere offering easy accessibility and moderately high accuracy at low cost. The time code contains Coordinated Universal Time (UTC) information and Universal Time (UT1) corrections. In addition to the time code, the satellite's position is included for free-space propagation time corrections. These position data are presently in the form of the satellite's longitude, latitude, and range from the earth's center. The UTC and UT1 information is a permanent feature of those satellites and will remain fixed in format. The satellite position information may undergo changes in form in an attempt to improve its performance.

## GOES SYSTEM DESCRIPTION

There are three GOES satellites in orbit, two in operational status and the third serving as an in-orbit spare. The two operational satellites are located at 135° and 75°W with the spare at 105°W longitude. The earth coverages are shown in figure 1.

The mission for the GOES satellites includes (1) continuous photography of the earth's surface, (2) collection of data on the space environmental Sun/Earth interaction, and (3) collection of remote-sensor data including flood, rain, snow, Tsunami, earthquake, and air/water pollution monitoring. It is in this third function that a need for a time code was realized since in many cases the data would be of greater value if it were labeled with the date as it is collected.

Some of these remote sensors are equipped with both a receiver and transmitter. Upon command from the satellite, these sensors, called data collection platforms (DCP's), are activated to transmit stored data to the satellite. The satellite relays these data to the NOAA Command and Data Acquisition (CDA) station at Wallops Island, VA, for processing and dissemination to users. The communications channel used to activate this response is called the interrogation channel. This channel is continuously relaying interrogation messages through the satellites. Its format is shown in figure 2.

The interrogation message is exactly one-half second in length or 50 bits, the data rate being 100b/s. The interrogation message is binary and phase modulates a carrier  $\pm 60$  degrees after being Manchester-encoded; i.e., data and data clock are modulo -2 added before modulating the carrier. An interrogation message consists of the first four bits representing a BCD word of the time code beginning on the one-half second

followed by a maximum length sequence (MLS) 15 bits in length for message synchronization and ending with 31 bits as an address for a particular DCP. When a DCP receives and recognizes its unique address it transmits its data to the satellite. Sixty interrogation messages are required to send the 60 BCD time-code words constituting a time-code frame. The time-code frame begins on the one-half minute and requires 30 seconds to complete.

#### TIME CODE SYSTEM

The time code is generated and integrated into the interrogation message at the CDA for transmission to the GOES satellites. The time-code generation system, shown in figure 3, is completely redundant and fully supported by an uninterruptable power supply. There is a communication interface between the equipment and NBS/Boulder using a telephone line. Over the telephone line, satellite position information is sent to the CDA and stored in memory for eventual incorporation with the time code and interrogation message. Data are also retrieved from the CDA via the telephone line to Boulder. These data include the frequency of the atomic oscillators and the time of the clocks relative to UTC as compared to TV transmissions from Norfolk, VA, and to the Loran-C transmissions from Cape Fear, North Carolina. These data are stored for retrieval in a Data Logger similar to that described in reference [1]. The Data Logger also measures and stores the time of arrival of the signals from both the Western and Eastern GOES satellites as received at the CDA. Besides the time and frequency monitoring functions, the Data Logger provides the information necessary for NBS staff at Boulder to remotely determine if and where malfunctions exist and how to correct for them by switching in redundant system components.

The interrogation message rate, 100b/s, is generated by the atomic oscillators in the time-code system. The interrogation message is one-half second in length or 50 bits. The time-code frame repeats every 30 seconds and begins on the one-half minute as shown in figure 4. The time-code frame contains a synchronization word, a time-of-year word (UTC), the UTI correction, and the satellite's position in terms of its longitude, latitude, and radius. The position information is presently updated only on the half hour.

The satellite position information is generated at Boulder using a CDC 6600 computer and orbital elements furnished by NOAA's National Environmental Satellite Service (NESS). NESS generates these orbital elements weekly from data obtained from their trilateration range and range rate (R&RR) tracking network. That network is illustrated in figure 5. The tracking data are obtained by measuring the R&RR to the Western satellite from the CDA, and sites in the states of Washington and Hawaii. The Eastern satellite is observed from the CDA, Santiago, Chile, and Ascension Island in the South Atlantic. The sites used in the R&RR network other than the CDA are known as turn-around ranging stations (TARS).

## RECEPTION

The interrogation channel signals are briefly characterized in figure 6. Typical antennas include simple low gain helixes or yagis. A receiver is shown in figure 7 as three modules; an RF/IF module, an L.O. injection module and a demodulator module. A block diagram of this receiver is shown in figure 8. This receiver is a coherent, synchronous digital receiver utilizing a phase-lock loop for demodulation and L.O. generation and a bit synchronizer for detection purposes.

The outputs of the receiver, data and data clock, are the inputs to a decoder clock (see reference 2 for a complete description of this clock). The decoder clock shown in figure 9 uses a four-bit microprocessor to demultiplex the data, extract the proper four bits of the time code every one-half second, and reconstruct the time-code frame. Once decoded, this time is loaded into Random Access Memory (RAM) and updated by incrementing the RAM clock in 10 ms steps by counting the data clock, a 100 Hz squarewave.

A prototype of a "smart" clock is shown in figure 10. This is essentially an addition of a second microprocessor to the decoder clock for the calculation of the free-space propagation delay from the CDA to the clock via the satellite. This delay value is then used with a delay generator to compensate for the free-space path delay.

## PERFORMANCE

The equation relating the time recovered from the satellite to the master clock at Wallops Island is given in figure 11. Term 1 is known to better than 1  $\mu$ s using the Data Logger at the CDA which compares the CDA clocks to Loran-C and TV-line 10. Using the measurement setups of figure 12, the smart-clock output on the chart recorder would draw a straight line if the orbit predictions are accurate and all equipment delays are constants; i.e., terms 2, 4, 5, and 6. Figure 13 shows raw data for 28 days. Each data point represents an average of measurements taken in one day at one-half-hour increments totaling 48 measurements per day. Figure 14 shows the same data with the CDA clock drift removed and the two jumps in delay which have been attributed to equipment changes at the CDA. The orbit predictions used to generate these data were derived from three sets of orbital elements extrapolating as much as 22 days beyond their date.

The results indicate a consistency in orbit determination and in the stability of equipment delays of about 10  $\mu$ s for the period under study. A claim for accuracy cannot be made, however, until the equipment delays at the CDA and in the receiving equipment have been evaluated and more measurements of this type are taken at points separated by large geographical distances.

Portions of the actual charts producing the data just discussed are shown in figure 15. The output, uncorrected for the free-space delay shows a 24-hour diurnal due to the satellite's orbit inclination and eccentricity. The corrected output, one point every half hour, lies in a straight line at least to a few microseconds on the average. Because the satellite position data are updated only every half hour, the corrected output deviates from a straight line between the half-hour updates at the same rate shown for the uncorrected output.

#### CONCLUSIONS

The time code has been broadcast from the two GOES satellites for more than one year. It has proven itself to be a reliable, low cost, and extremely simple system for moderately high accuracy time. The time code is now considered a permanent feature of the GOES satellites and should see an expanding list of users for many purposes within the Western Hemisphere.

The results presented in this paper indicate a potential accuracy of 10 to 20 microseconds. These figures need to be verified, however, by additional observations at points widely separated geographically. Equipment delays need further study. The clock drift and the effect of equipment changes at the CDA need to be offset or eliminated to make the time-code system a true one-way time transfer technique.

#### REFERENCES

1. D. D. Davis, "A Microprocessor Data Logging System for Utilizing TV as a Time/Frequency Transfer Standard," Precise Time and Time Interval (PTTI) Applications and Planning Meeting, November 30 - December 2, 1976.
2. J. V. Cateora, D. D. Davis, and D. W. Hanson, "A Satellite-Controlled Digital Clock," NBS Technical Note 681, June 1976.

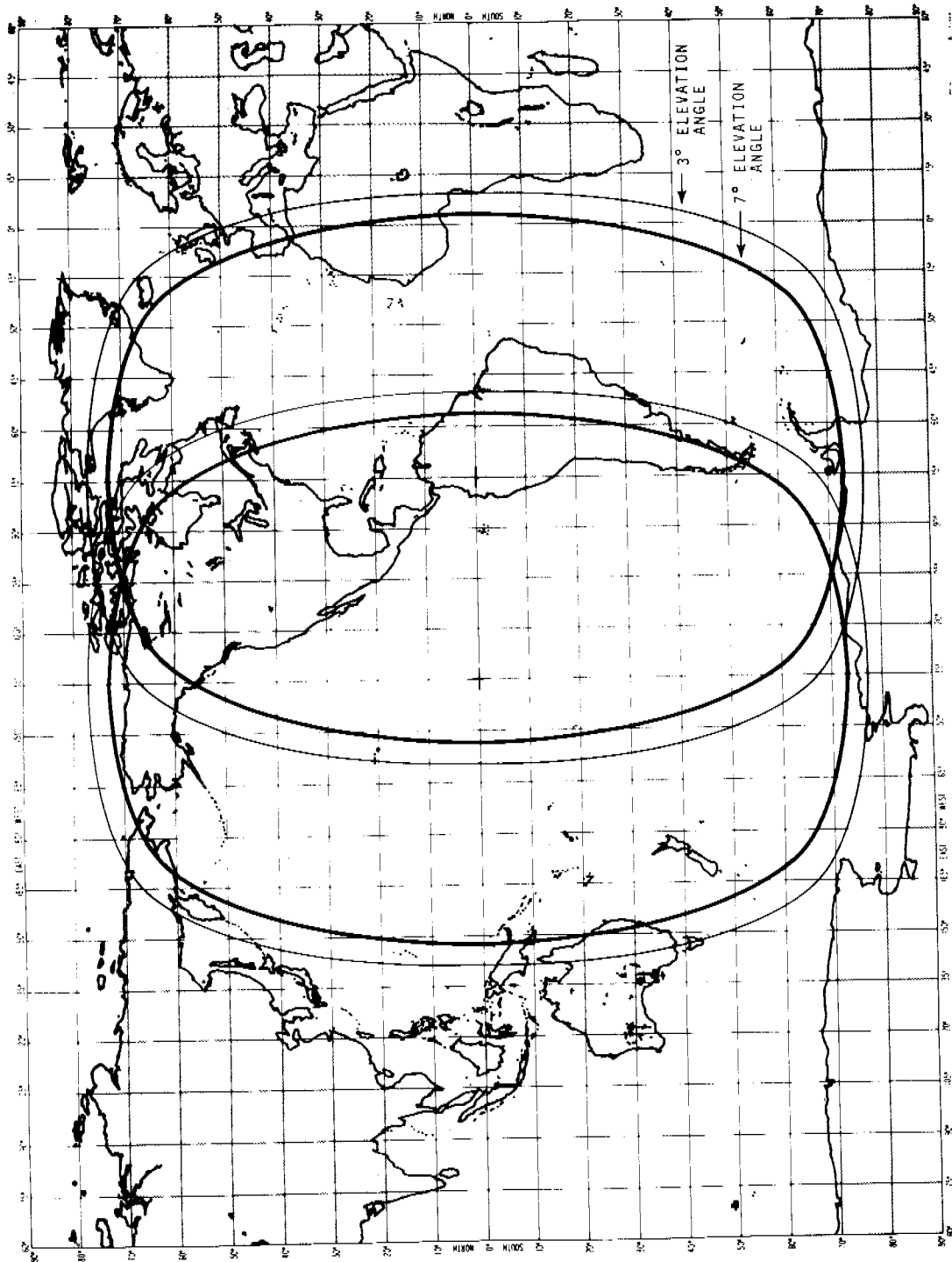

Fig. 1-GOES coverage

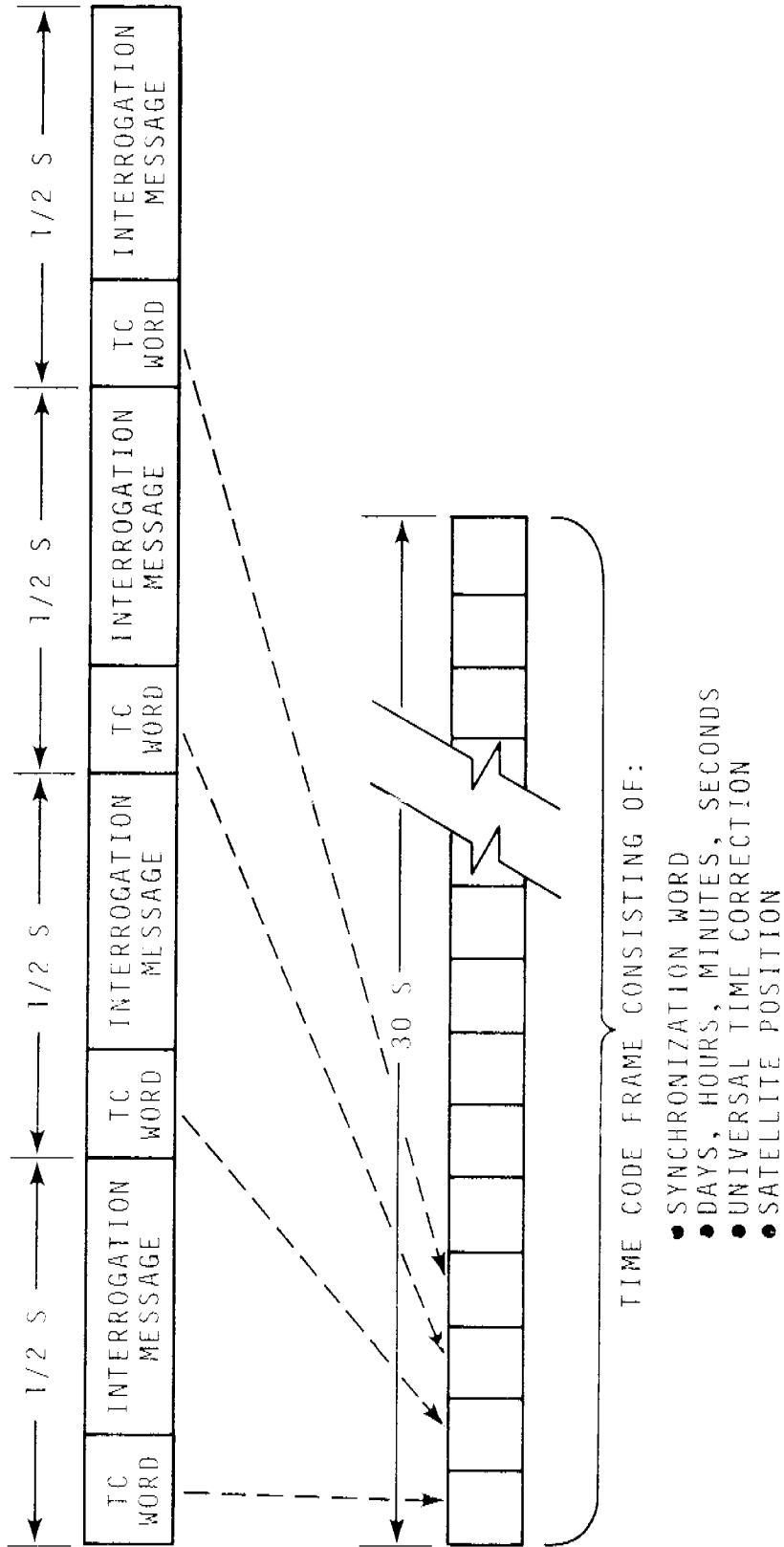

Fig. 2-Interrogation message format

TIME CODE GENERATION AT THE CDA, WALLOPS ISLAND, VA

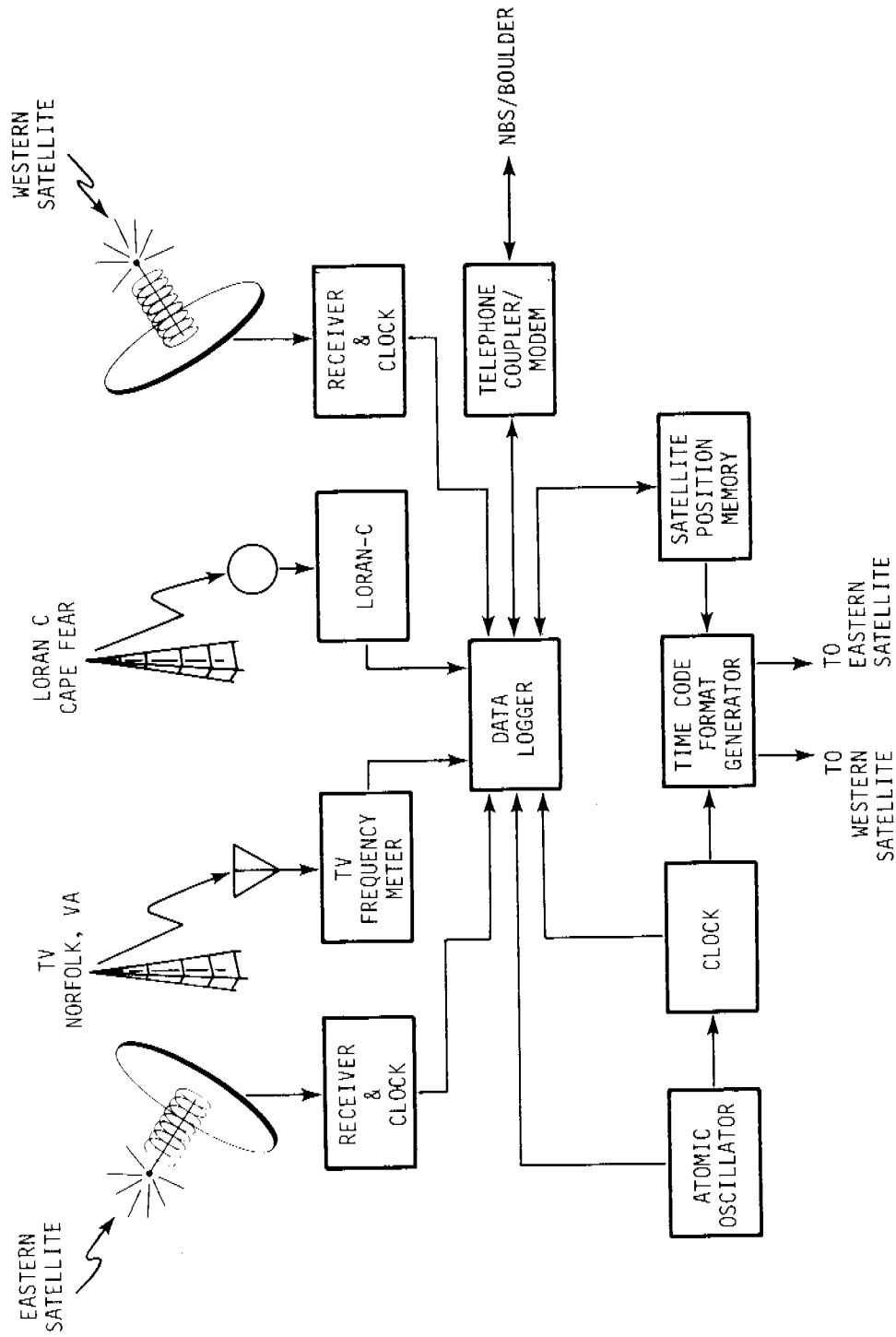

Fig. 3-Time code generation equipment at the CDA Wallops Island, VA



# TIME CODE FORMAT

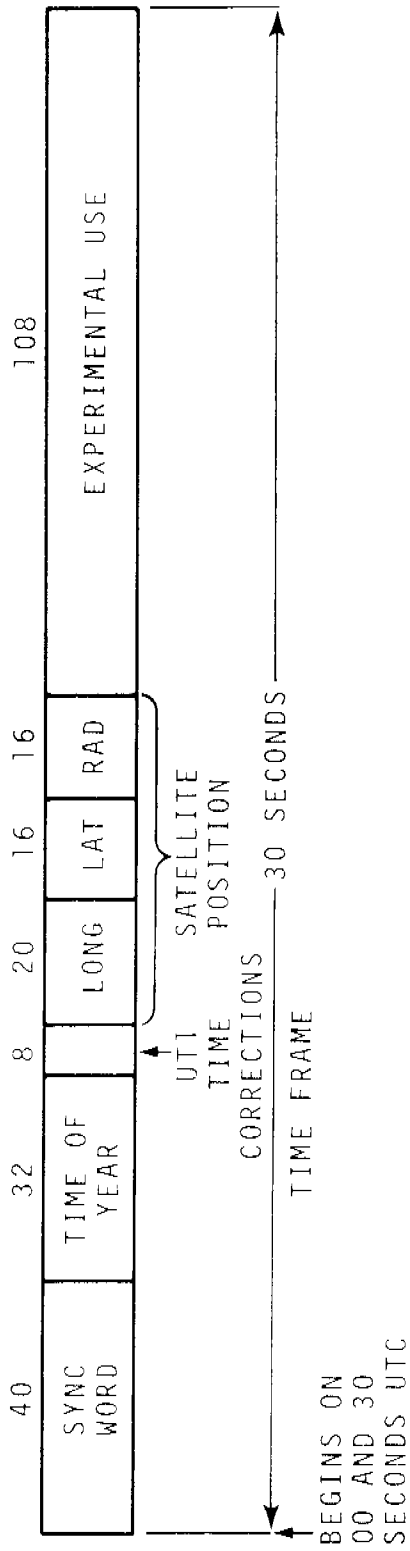

Fig. 4-Time code format

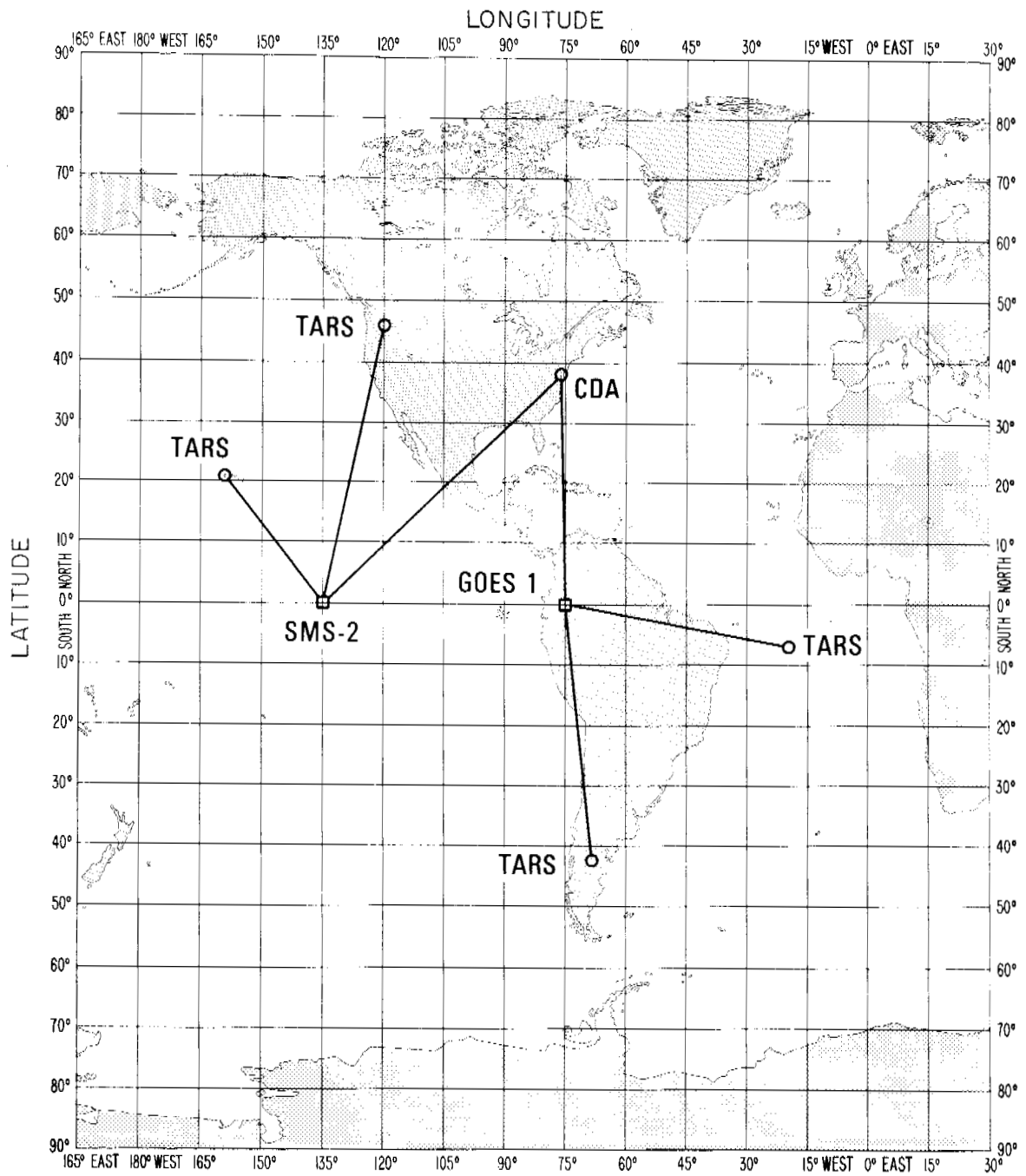

Fig. 5-Tracking network for the GOES satellites

## INTERROGATION CHANNEL SIGNAL CHARACTERISTICS

	WESTERN SATELLITE	EASTERN SATELLITE
FREQUENCY	468.8250 MHz	468.8375 MHz
POLARIZATION	RHCP	RHCP
MODULATION	CPSK ( $\pm 60^\circ$ )	CPSK ( $\pm 60^\circ$ )
DATA RATE	100 BPS	100 BPS
SATELLITE LOCATION	135° W	75° W
SIGNAL STRENGTH (OUTPUT FROM ISOTROPIC ANTENNA)	-139 dBm	-139 dBm
CODING	MANCHESTER	MANCHESTER
BANDWIDTH	400 Hz	400 Hz

Fig. 6-Interrogation channel signal characteristics

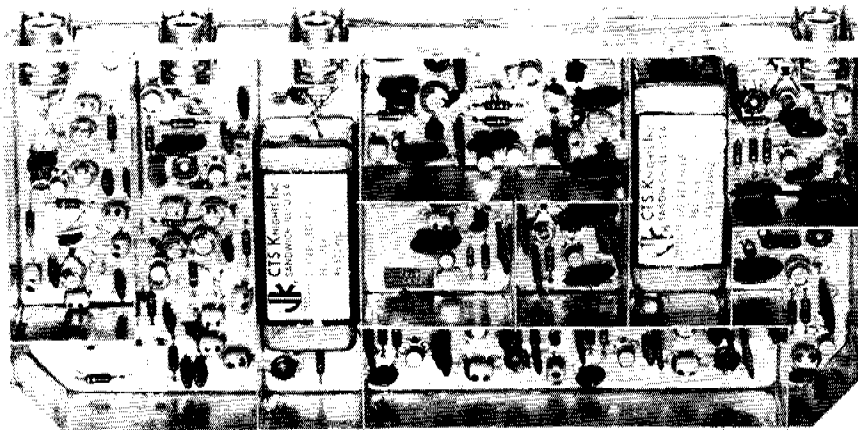
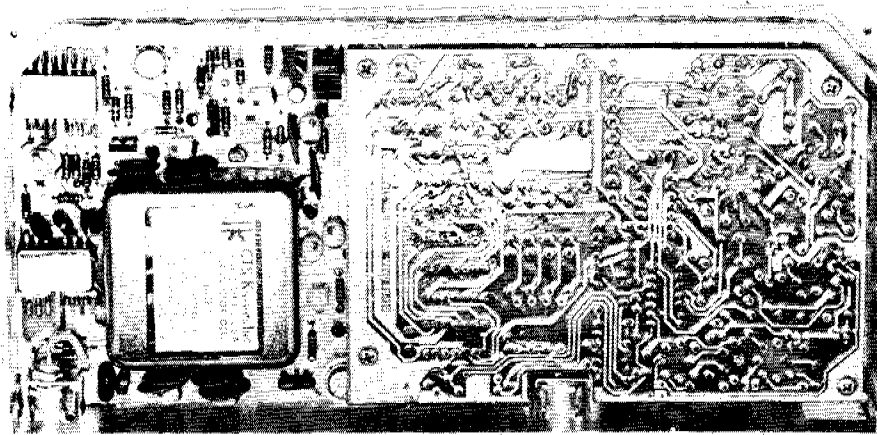

Fig. 7-Interrogation channel receiver

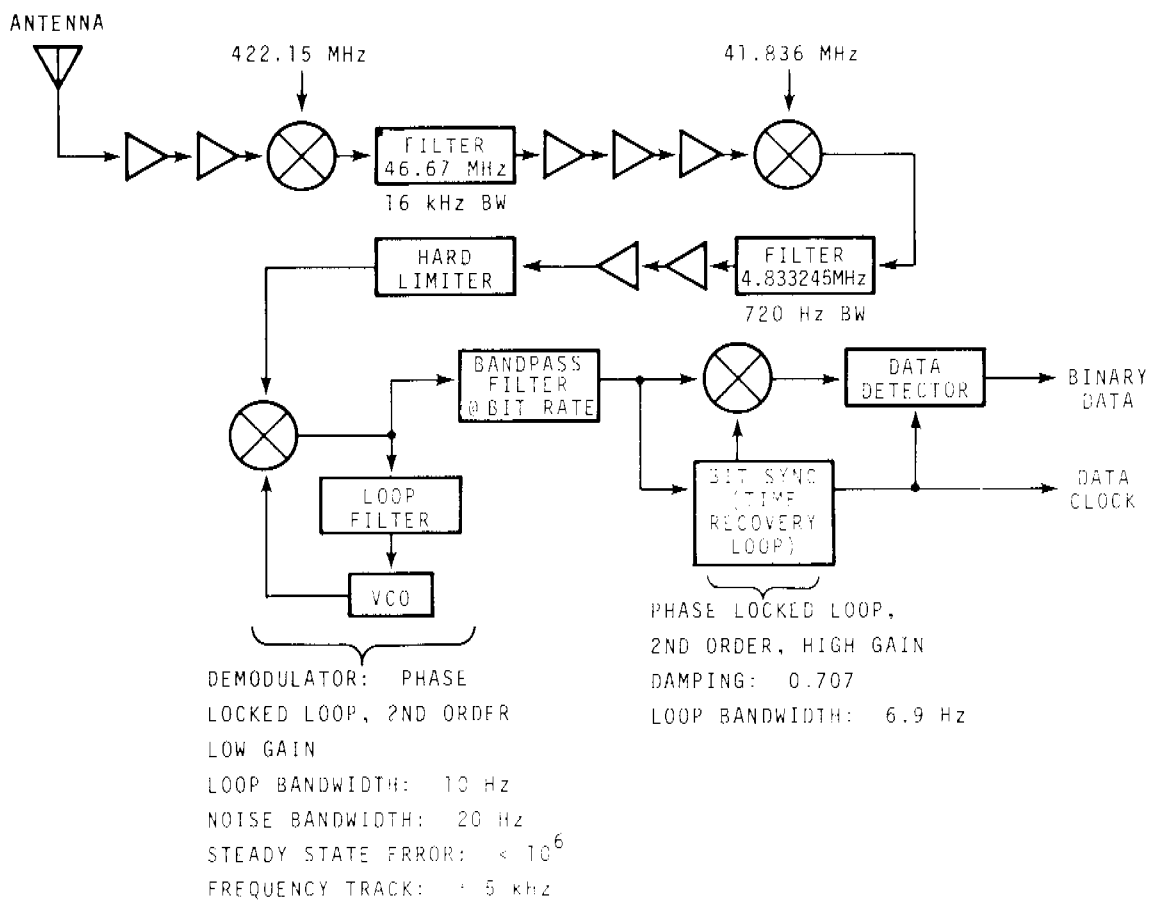

Fig. 8-Interrogation channel receiver block diagram

NBS TECHNICAL NOTE 681

U.S. DEPARTMENT OF COMMERCE  
National Bureau of Standards

A Satellite-Controlled Digital Clock

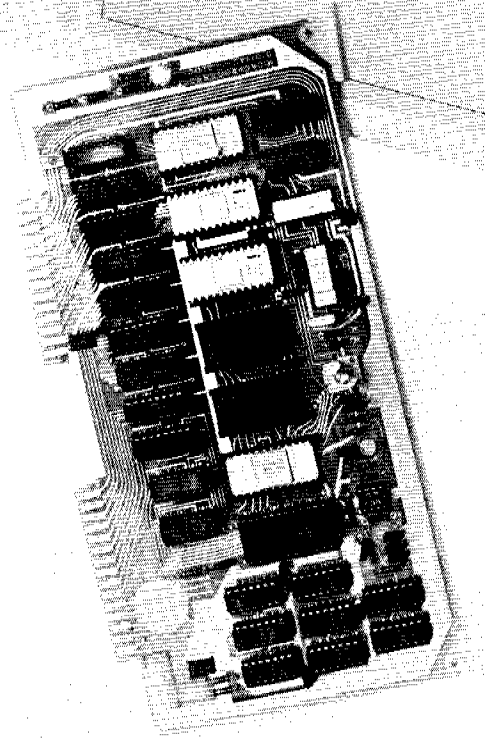

Fig. 9-Decoder clock

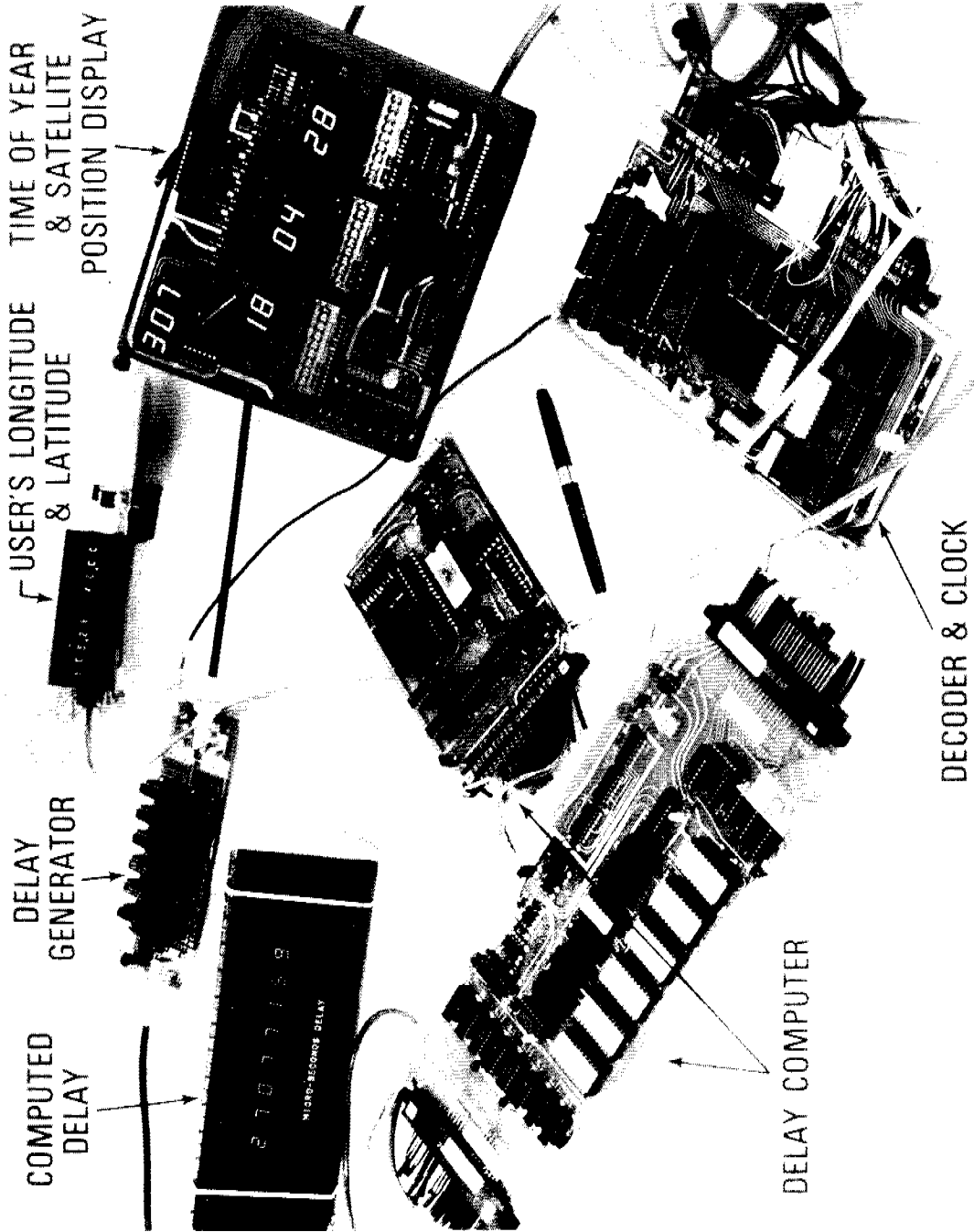

Fig. 10-Smart clock

$$\begin{aligned}
 \text{UTC(NBS)} - \text{SAT/NBS} = & \text{ }^1 (\text{UTC} - \text{CDA}) + \text{ }^2 (\text{CDA EQUIP DELAY}) + \\
 & \text{ }^3 \left( \text{FREE SPACE} \right) + \text{ }^4 \left( \text{SATELLITE} \right) + \\
 & \left( \text{PROPAGATION} \right) \text{ DELAY} \quad \left( \text{TRANSPONDER} \right) \text{ DELAY} \quad + \\
 & \text{ }^5 \left( \text{IONOSPHERE \&} \right) + \text{ }^6 \left( \text{RECEIVER \&} \right) \\
 & \left( \text{TROPOSPHERE} \right) \text{ DELAY} \quad \left( \text{CLOCK} \right) \text{ DELAY}
 \end{aligned}$$

Fig. 11-UTC(NBS)-SAT/NBS



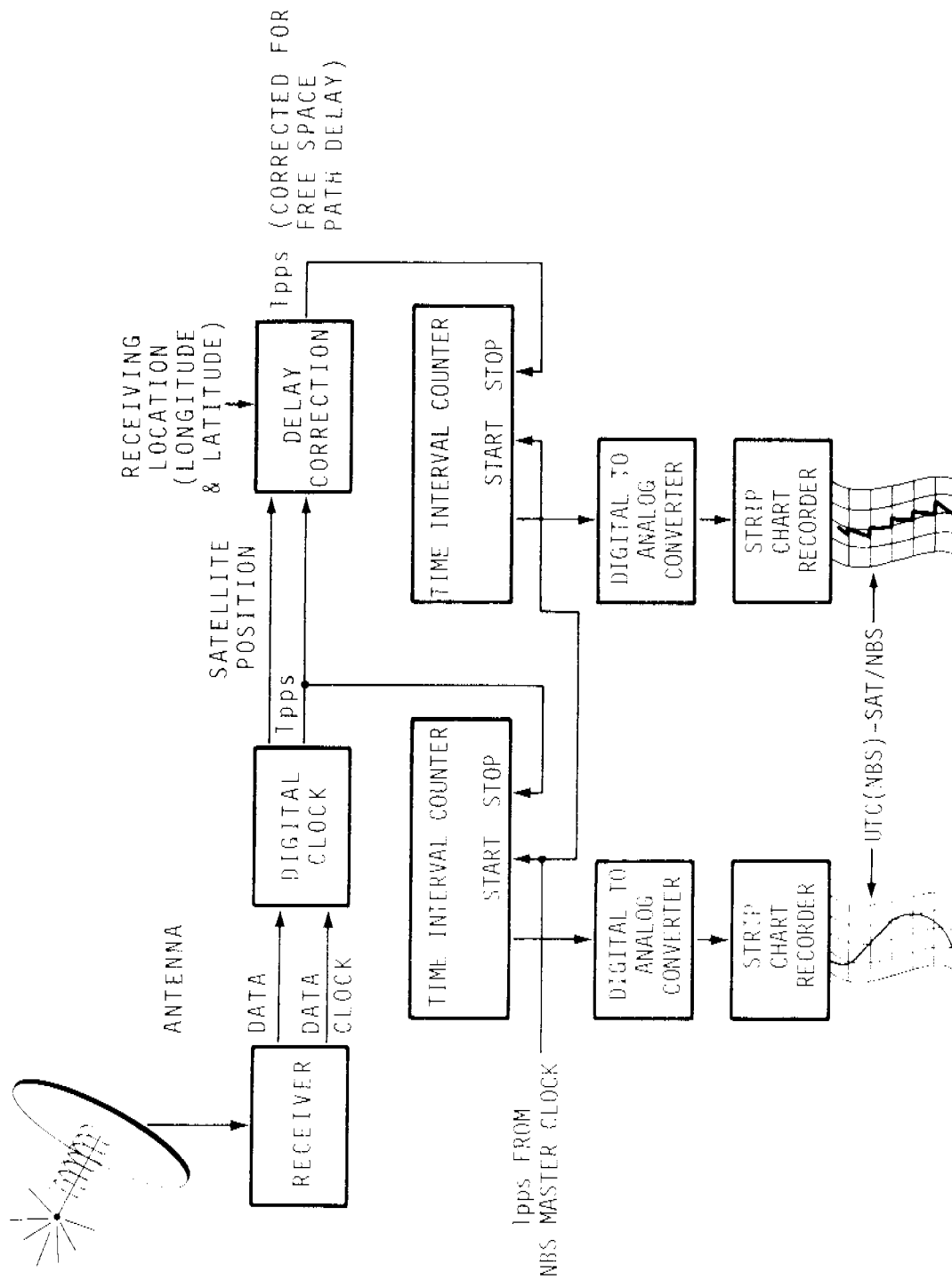

Fig. 12-Measurement of UTC(NBS) - SAT/NBS

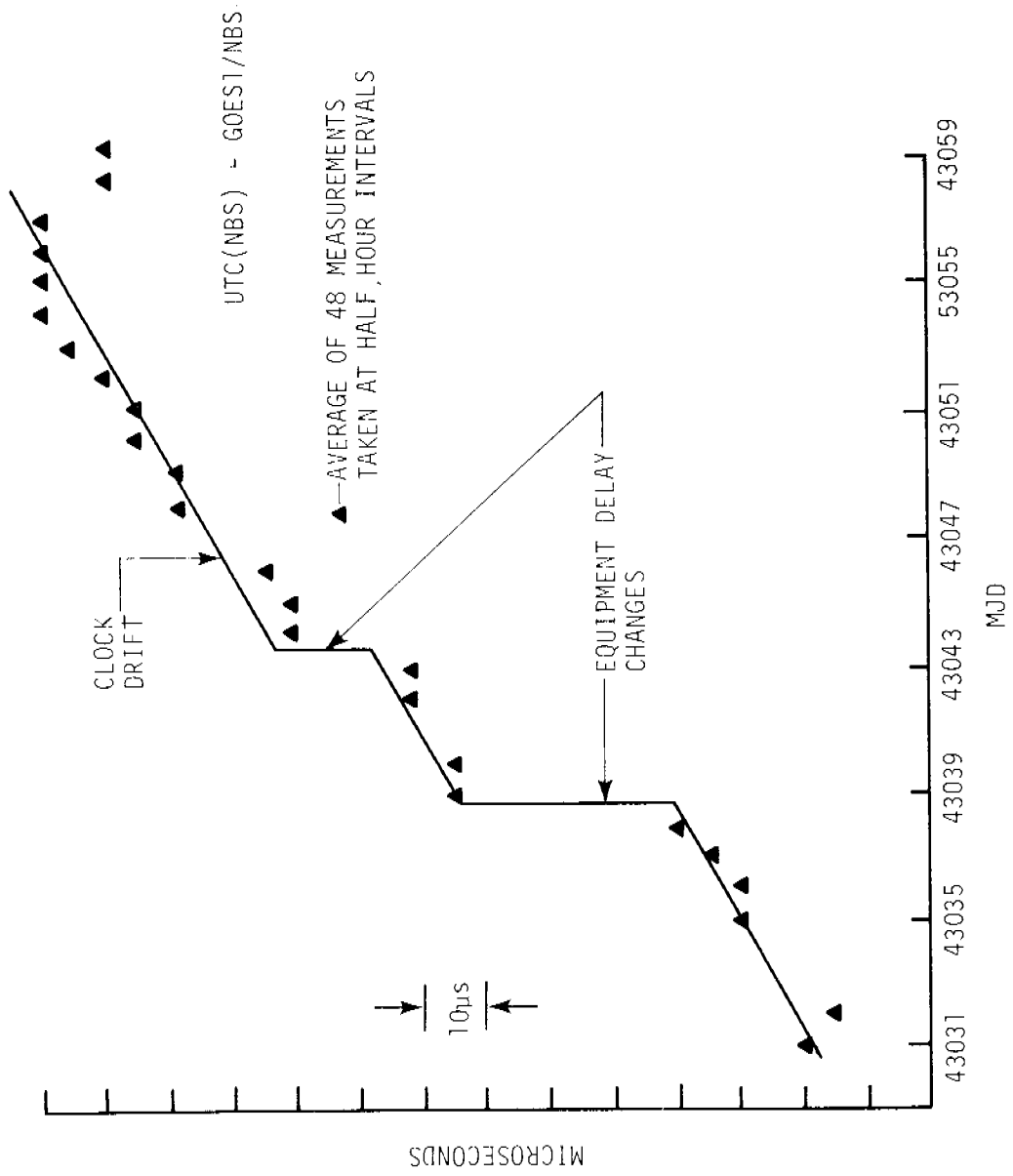

Fig. 13-UTC(NBS)-GOES 1/NBS; raw data

UTC(NBS)-GOES1/NBS  
 CORRECTED FOR CLOCK DRIFT  
 & EQUIPMENT DELAY CHANGES  
 AT CDA WALLLOPS ISLAND, VA

○ — AVERAGE OF 48 MEASUREMENTS  
 TAKEN AT HALF HOUR INTERVALS

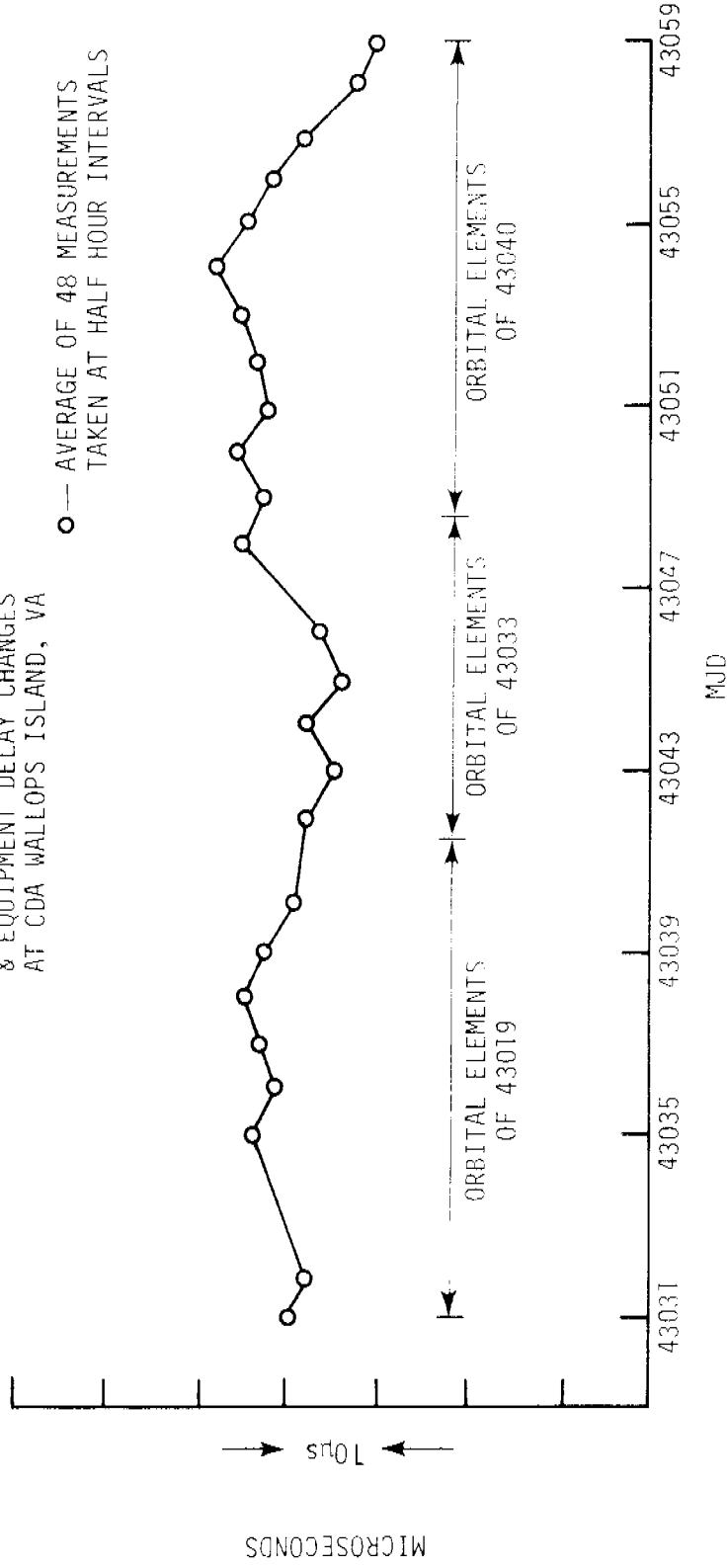

Fig. 14-UTC(NBS)-GOES 1/NBS; clock drift and equipment delay changes removed

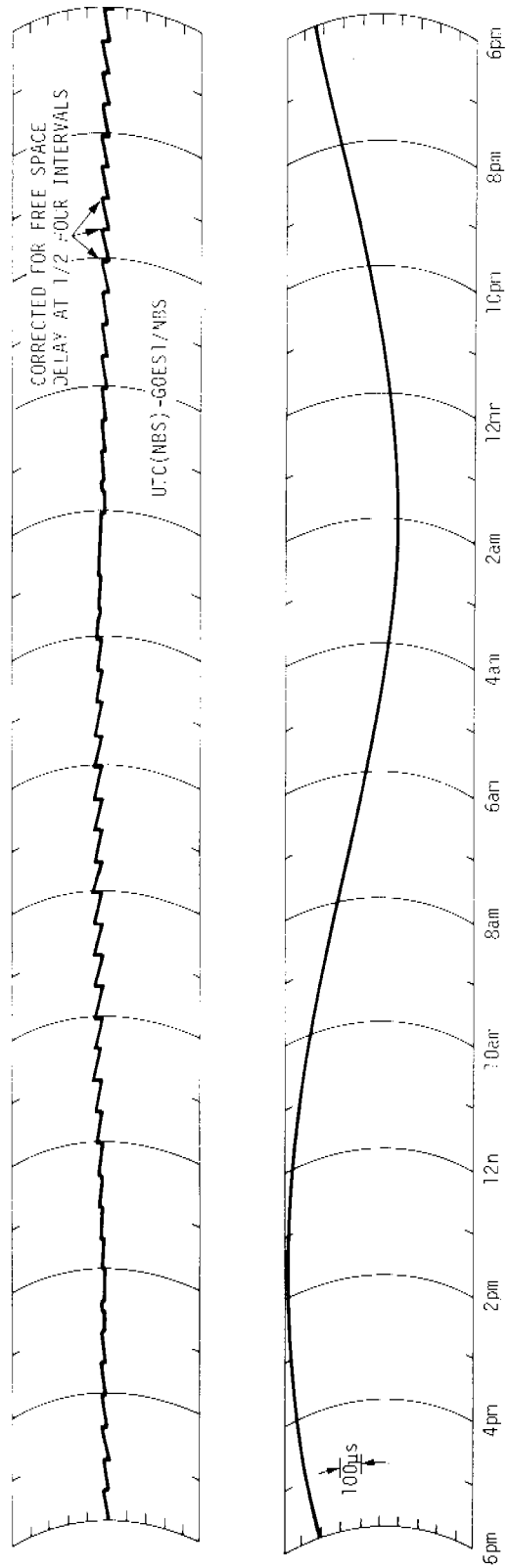

Fig. 15-Satellite output: corrected and uncorrected