

SPACEBORNE RUBIDIUM FREQUENCY STANDARD FOR NAVSTAR GPS

D. E. Ringer, J. Gandy (Rockwell International)
E. Jechart (Efratom)

ABSTRACT

The Navstar Global Positioning System is a multi-service navigation system with the Joint Program Office at SAMSO. This system utilizes a passive navigation system (one way signals from satellite to user) with a frequency standard stability (σ_y) of better than 10^{-12} at one day for the initial phase of the program and a stability of better than 10^{-13} at one day for the operational system. This paper describes the development and test of the miniature Rb gas cell atomic clock built by Rockwell International for the initial Navstar GPS satellites. This small clock provides the timing signal for the dual frequency PRN Navigation System. This 170 cubic inch atomic clock weighs 8.8 pounds and operates on 24.5 watts DC. This Frequency standard features two modes of operation (open loop and closed loop) with remote frequency adjust capability in either mode. The frequency standard utilizes two crystals and operates at a submultiple of the navigation system carrier frequencies, 10.23 MHz.

INTRODUCTION

The GPS satellites require frequency standards which are small, lightweight and ruggedized to meet launch requirements and are sufficiently reliable to meet 5 years of on-orbit service. Stability of the frequency standard must be such that precise timing is maintained between the periods of satellite update. The frequency standard to be utilized for the GPS concept validation phase (Phase I) is a Rockwell built Rubidium (Rb) device shown in Figure 1.

Rb Frequency Standard Development Program

The specific requirements placed upon each of the spaceborne frequency standards to ensure the performance of its portion of the NAVSTAR GPS function are given by Table 1 and Figures 2 and 3.

After conducting a survey of available frequency standards, it was decided to undertake a development program based upon a commercial Rb frequency standard produced by Efratom Inc. The Efratom model FRK Rubidium frequency standard was selected because its size, weight,

power and stability met the GPS criteria and it had previously flown on NRL's satellite, NTS I. After comparing this unit with the spaceborne frequency standard requirements Rockwell International concluded that the following modifications and additions were required:

1. Substitute MIL parts for commercial parts.
2. Analyze and revise circuits for optimum performance.
3. Repackage to meet shock and vibration requirements.
4. Improve thermal design for vacuum operation.
5. Characterize the "C" field.
6. Shield for natural radiation.
7. Add 10.23 MHz synthesizer circuit with power amplifier.
8. Add digital tuning circuits for both C-field and varactor frequency adjustment capability.
9. Redesign power supply to accommodate the additional circuits.

In this paper we will review the miniaturization techniques utilized by Efratom in their Rb frequency standard and briefly look at the major additions incorporated by Rockwell. The major additions consist of the 10.23 MHz synthesizer, digital tuning and repackaging as shown by figure 4.

Rb Miniaturization Techniques

The first Efratom step towards a compact design of their commercial unit was the reduction in size of the optical package. This was accomplished by abandoning the optical filter and by combining the filter function with the resonance function in the Rubidium gas cell. This "integrated cell" design is achieved by using suitable isotope mixtures in the lamp as well as the gas cell. This also has the advantage of placing the lamp much closer to the cell and thus makes more efficient use of the lamp radiation.

The efficient application of the 6.83.....GHz magnetic field to the gas cell was also a variation from the classical approach. The cell is contained inside a microwave cavity which must be excited in a mode that possesses a magnetic field component along the optical axis. With conventional designs this requirement is satisfied by exciting the cavity in the TE 011 mode. Unfortunately this mode requires at 6.83.....GHz a minimum cavity diameter of about 2-3/4 inches and it is not possible to reduce this size substantially by using a dielectric

filling. Therefore this type of cavity is not suited for miniaturization, particularly since there is also a mismatch between its size and that of the much smaller gas cell.

To overcome this problem a new cylindrical cavity was developed which is excited in the TE 111 mode. Its diameter is only 1.1 inches, however, its length would have been excessive. To reduce the length, two adjustment screws have been inserted which project into the region of maximum electric field intensity inside the cavity. This results in an overall length of only 1.57 inches. The gas cell, which is fitted snug inside the cavity, is provided with two recessed funnels (see figure 5) to permit insertion of the adjustment screws. This design made it actually possible to increase the size of the gas cell and at the same time reduce the overall size of the resonance assembly.

The adjustment screws also serve the purpose of increasing the magnitude of the RF magnetic field component in the direction of the optical axis. Since in the TE 111 mode this component is strongest on the periphery of the cavity the photo detector has been increased in size to almost the diameter of the cavity to permit interception of the perimeter radiation. The photo cell is sandwiched between the cavity and the gas cell and thus covers the cell's entire face. This design has the added benefit of intercepting most of the available optical radiation.

10.23 MHz Frequency Translation Loop

Because the output of the Efratom frequency standard is at 10.0 MHz, there exists a need to convert the Rubidium loop frequency to the GPS requirement of 10.23 MHz. This function could be accomplished economically by direct digital synthesis but the existing commercial unit has marginal phase noise performance from 1 to 10 hertz from the carrier. Therefore a decision was made to incorporate a secondary loop which would serve the dual purpose of frequency translation and improvement of spectral purity. The strategy behind this secondary loop is to use a very pure oscillator in the secondary loop and then to set the loop bandwidth such that there is an attenuation of primary loop phase noise in the region above 0.1 Hertz from the carrier and then have the primary loop take over very close (0.1 Hertz) to the carrier.

The secondary VCXO consists of a crystal oscillator within a stainless steel Dewar flask. The temperature inside the flask is precisely controlled by two proportional ovens. The quartz crystal within the oscillator is a Premium 'Q' type which has excellent radiation resistance. The method used for phase locking the secondary loop consists of heterodyning the 10.0 MHz against the 10.23 MHz oscillator

output and then using the difference frequency as an error frequency input (see figure 6).

Table 2 is a tabulation of the pertinent performance characteristics of the secondary loop. The phase noise from the primary loop is attenuated by an order of magnitude at 1 Hertz with an additional order of magnitude at 10 Hertz. At approximately 25 Hertz a 3 pole filter increases the attenuation by 18 db/octave. This second filter attenuates the 20 KHz sidebands generated in the 230 KHz synthesizer.

Digital Tuning

The remote tuning technique is similar in concept to the tuning of the Efratom unit in the laboratory. This method increases or decreases the current to the resonator C-field. Also, in the event of Rb circuit failure, the 10.23 MHz VCXO can be operated independently of the Rb loop and the frequency can be remotely tuned by adjusting the VCXO control voltage. The frequency control requirements are as follows:

1. Provide a fixed current source to induce a magnetic field for an absolute frequency.
2. Provide a tunable current source to induce a controlled magnetic field change.
3. Provide a tunable voltage source to induce a controlled change in the output frequency of the 10.23 MHz VCXO when operating in the back-up mode (VCXO only).

The Rb frequency control consists of a fixed current source of approximately 7.5 ma which sets the frequency output near 10.23 MHz. This fixed current source is paralleled by a current source which is variable from 0 to 2.2 ma. The sum of these two sources determine the total C-field current and, thus, the output frequency. The tuner specification requires a total range of 4×10^{-9} with steps no larger than 4×10^{-12} . Data developed on typical Rb physics packages indicates that a one micro-ampere current change will result in a frequency change of 2 ± 0.4 parts in 10^{12} . If the 2.2 ma variable current is divisible into 4096 parts, we have a minimum current change of approximately 0.5 microamperes per step. This corresponds approximately to a minimum step change of one part in 10^{12} a total range of 4096 (1×10^{12}) or 4×10^{-8} . The VCXO tuner has a specified tuning range of 4×10^{-7} with steps no larger than 2.5×10^{-10} .

This tuning technique is implemented as shown by figure 7. A serial output from the command decoder (TTL output) is interfaced with the digital tuning system. The TTL word is translated to C-MOS levels and loaded into a serial to parallel register and then into a holding

register. The 12 bit D to A converter then provides a voltage output (0 to 10 volts) to bias the tunable current and voltage sources.

Repackaging

The major repackaging considerations included the magnetic and thermal effects of the frequency standard in the spacecraft environment.

Magnetic Shielding

To insure that the clock frequency is not affected by the expected one gauss change in magnetic field near the frequency standards three shields are utilized (figure 8). The resonator is first shielded from the electronics with a 0.050 inch thick mumetal shield. The total physics package is then contained within a 0.030 thick mumetal shield. Finally, to shield the entire frequency standard from external fields it is covered by a 0.050 thick mumetal cover and a 0.030 thick mumetal base shield.

Thermal Control

To maintain the necessary temperature control of the clocks temperature sensitive components a total of six heaters are used. The 10.23 MHz crystal is temperature controlled within a double oven, whereas the 10 MHz crystal is kept near its turn-around point with a single heater. To generate the correct vapor pressure the Rb lamp is kept at approximately 109°C with a heater as shown by figure 9. Two heaters are also used to control the resonator assembly temperature. One heater is wrapped around the resonator assembly and is maintained at 75°C. This assembly is then contained within a copper oven which is controlled to 68°C.

Thermal Dissipation

Heat is transferred from the individual frequency standard components through the clock's aluminum frame and baseplate to the spacecraft structure. First, all heat sources were identified (heaters and electrical components); then, heat paths between the heat sources and base plate were identified. For those cases where the heat paths were not sufficient additional measures were taken to increase the capacity for heat flow as shown by figure 10. The techniques used to enhance the heat transfer were high conductivity bonding material between beryllium oxide insulators and circuit boards, thermal compound between mating surfaces (of the physics package, the 10.23 MHz oscillator, and the 10 MHz crystal interface). Also, torque requirements were established for the mounting screws used to secure the circuit boards. RTV was also added at the mounting edges of the circuit boards. And finally, the shield at the baseplate was bonded

with a thermally conductive adhesive. Although the operating temperature of the frequency standard is predicted to be from 20 to 35°C on orbit, a component temperature analysis was performed with the base plate at 45°C (worst case). This analysis demonstrated that components were operating well within their specified temperature range.

Development Testing

To verify design concepts and analysis, one prototype and three Engineering Models (EM) were built for purposes of being subjected to development tests. The major development test results are presented here.

Stability - One of the first tests conducted on the prototype unit was long term stability in a vacuum with the baseplate at 28.4°C. Stability of this unit, as shown in figure 11, was 3.4×10^{-13} at a tau of 10^5 seconds. This unit also displayed drift of 3.5 parts in 10^{13} per day. More recent stability data for EM2 was taken at ambient temperature and pressure conditions out to a tau of 3×10^4 seconds; a stability of 2×10^{-13} was demonstrated.

Phase noise - Two engineering units (EM1 & EM2) were tested for phase noise from 1 to 1000 Hertz from the carrier. Both units were at least 10 db better than specification requirements (see figure 12).

Power Demand - A test of power vs baseplate temperature was conducted on EM2 in a vacuum. The test was conducted at three voltage levels. As shown in figure 13, at the expected on-orbit temperature of 35°C and the nominal voltage of 26.5 VDC the power required for operation was 24.5 watts. For the worst case test at the coldest expected temperature of 20°C and a maximum voltage of 28 VDC the power demand was 28 watts.

Frequency change with Temperature - The EM1 test unit was placed in a vacuum and stabilized at 46°C. The temperature was then reduced to 24.6°C in less than 1-1/2 hours. After stabilization, the frequency change was measured to be 2 parts in 10^{12} as shown on figure 14.

Cold Start - To verify the ability of the unit to start after being subjected to low temperatures EM2 was stabilized at -30°C (10°C lower than worst case spacecraft temperature). The unit then responded to the turn-on command and the power output was measured to be well within the 17 to 20 dbm specification requirement as shown by figure 15.

Magnetic Susceptibility - The EM2 test unit was placed in a magnetic field which was controlled with a helmholtz coil as shown in figure 16. After several unsuccessful attempts to determine frequency changes with a magnetic field change of less than one gauss the unit was subjected

to a 5 gauss change. The test resulted in a frequency change of less than 2×10^{-13} per gauss in the most sensitive axis (optical axis).

Shock and Vibration - In addition to the test data included here the units have successfully completed pyrotechnic shock and vibration tests. The vibration testing included a test at $0.35 \text{ g}^2/\text{Hz}$ and $0.5 \text{ g}^2/\text{Hz}$. This latter level is far in excess of the levels expected during launch.

Future Tests - Presently, the units do not meet electromagnetic interference requirements. Therefore, modifications and testing will continue in this area. Also, a long term stability test is planned to be conducted with the unit in a vacuum and the baseplate temperature being cycles 4°C . This test will closely simulate the expected on-orbit conditions.

TABLE 1 - FREQUENCY STANDARD REQUIREMENTS

● PERFORMANCE	
OUTPUT FREQUENCY	10,229,999.99545 Hz
PRIMARY MODE	DIGITAL TUNING CONTROL OF RUBIDIUM "C" FIELD $4 \times 10^{-12} \Delta f/f$ STEPS ($\pm 2 \times 10^{-9} \Delta f/f$ RANGE)
BACKUP MODE	DIGITAL TUNING CONTROL OF 10.23 MHz VCXO $2.5 \times 10^{-10} \Delta f/f$ STEPS ($\pm 2 \times 10^{-7} \Delta f/f$ RANGE)
DRIFT	$1 \times 10^{-12} \Delta f/f/\text{DAY}$
RF OUTPUT POWER	+17 dBm TO 20 dBm
● ENVIRONMENTAL	
OPERATING TEMPERATURE RANGE	+20°C TO +45°C 4°C/DAY MAXIMUM EXCURSION 5°C/HOUR MAXIMUM RATE OF CHANGE
RANDOM VIBRATION	QUALIFICATION 0.35 G ² /Hz
PYROTECHNIC SHOCK	1400 G's MAXIMUM 10 kHz MAXIMUM
TRANSIENT MAGNETIC FIELD	ONE GAUSS, ONE SECOND

TABLE 2 - 10.23 MHz SYNTHESIZER

WORST CASE	LOOP ANALYSIS
GAIN MARGIN	42 dB
ϕ MARGIN	58°
OPEN LOOP GAIN	86 dB
BANDWIDTH	0.1 Hz
SETTLING	11.2 SECONDS
DAMPING RATIO	0.62
STEADY STATE ERROR	$2.93 \times 10^{-12} \Delta f/f$
HOLD IN-PULL IN RANGE	$+2 \times 10^{-7} \Delta f/f$
MAXIMUM SWEEP LOCKRATE	1.02 RAD/SEC ²
LOCKIN RANGE	1.88 RAD/SEC ²
VCXO CONTROL NOISE REJ	24 dB/OCT AT > 25 Hz

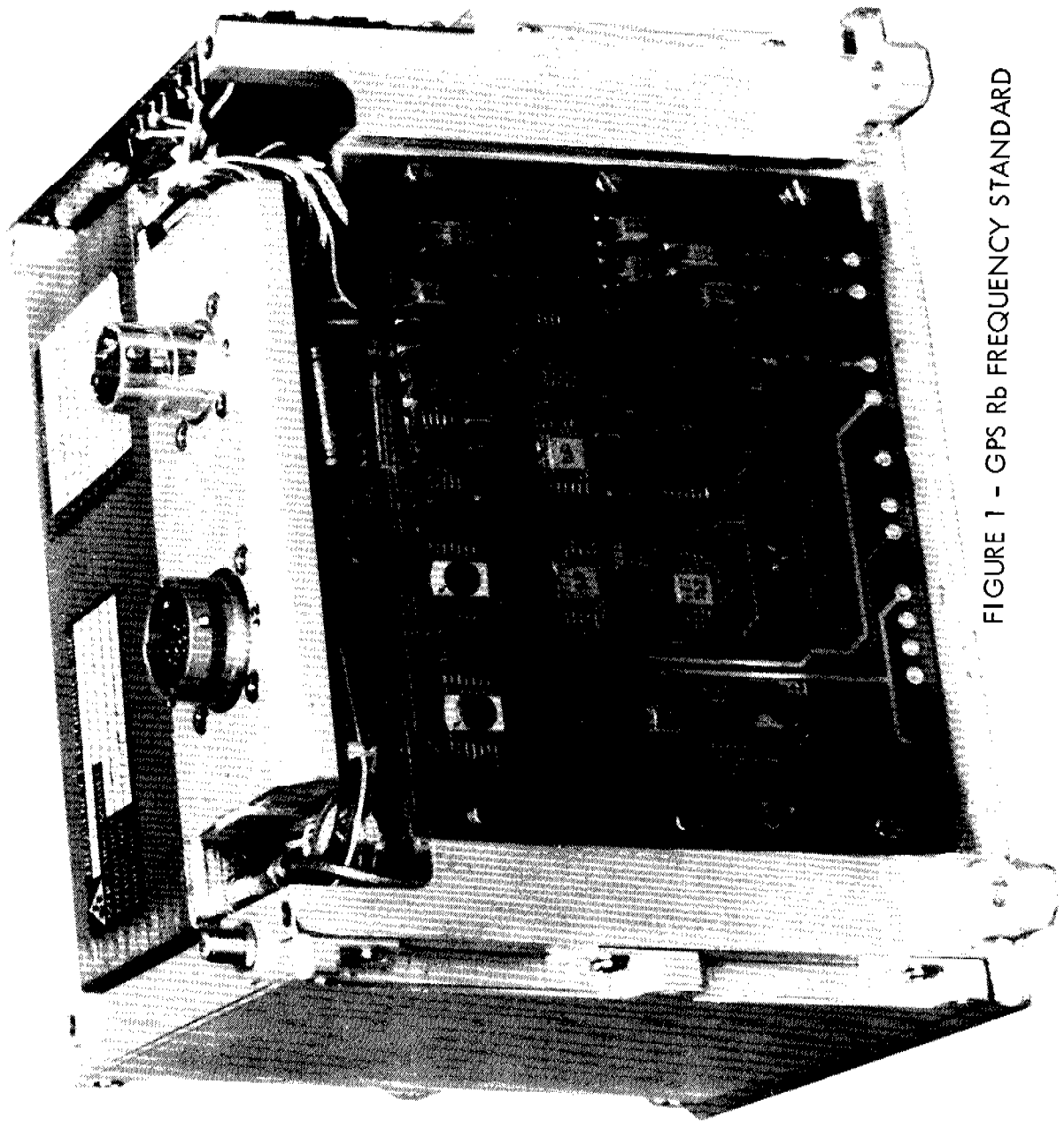

FIGURE 1 - GPS Rb FREQUENCY STANDARD

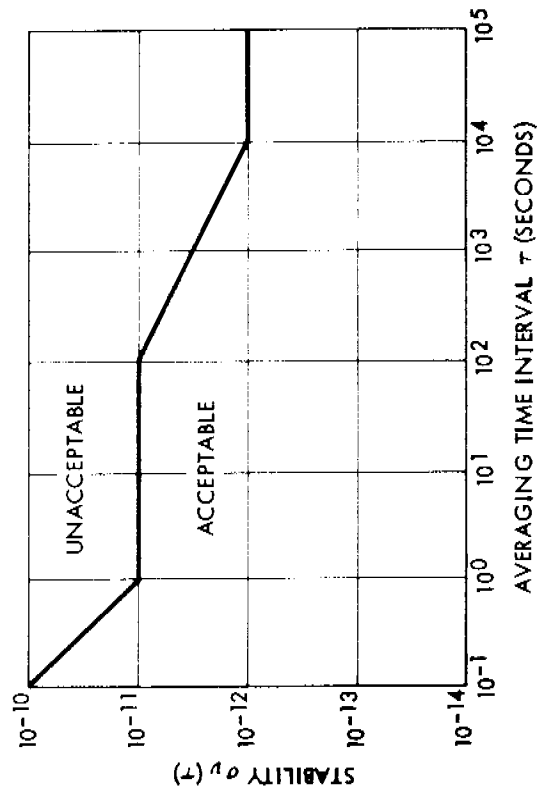

FIGURE 2 - STABILITY REQUIREMENTS

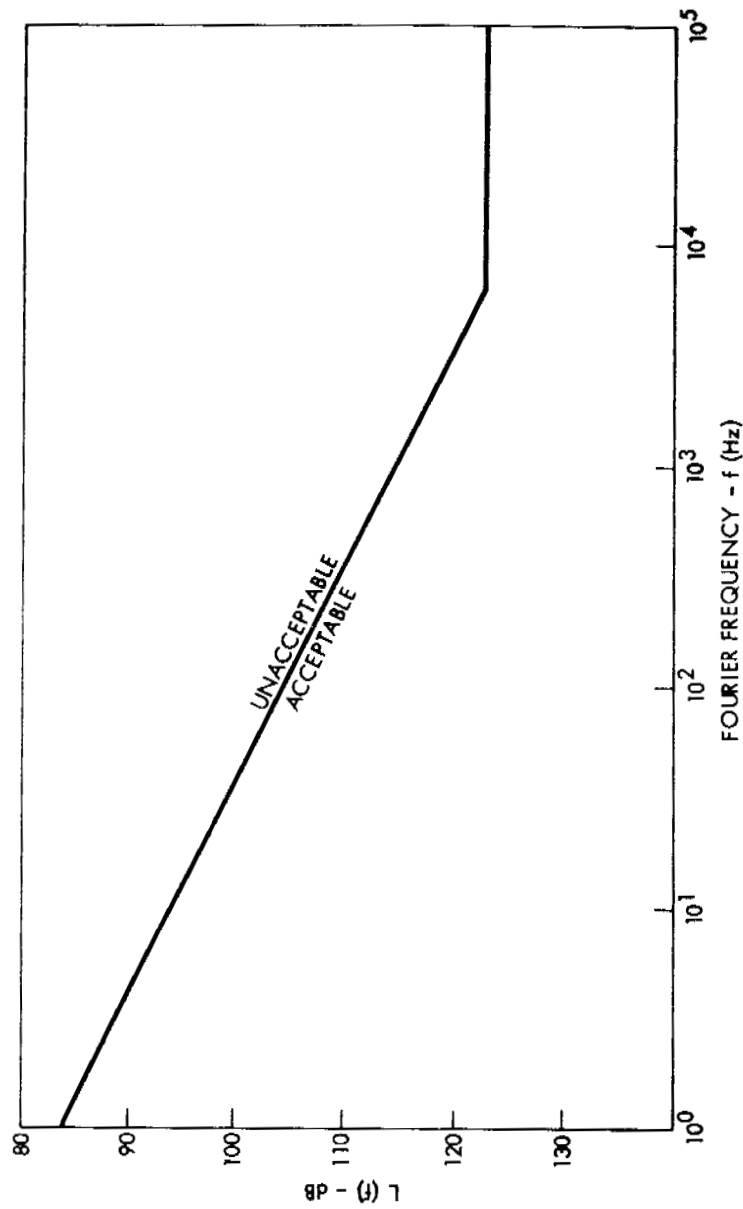

FIGURE 3 - PHASE NOISE REQUIREMENTS

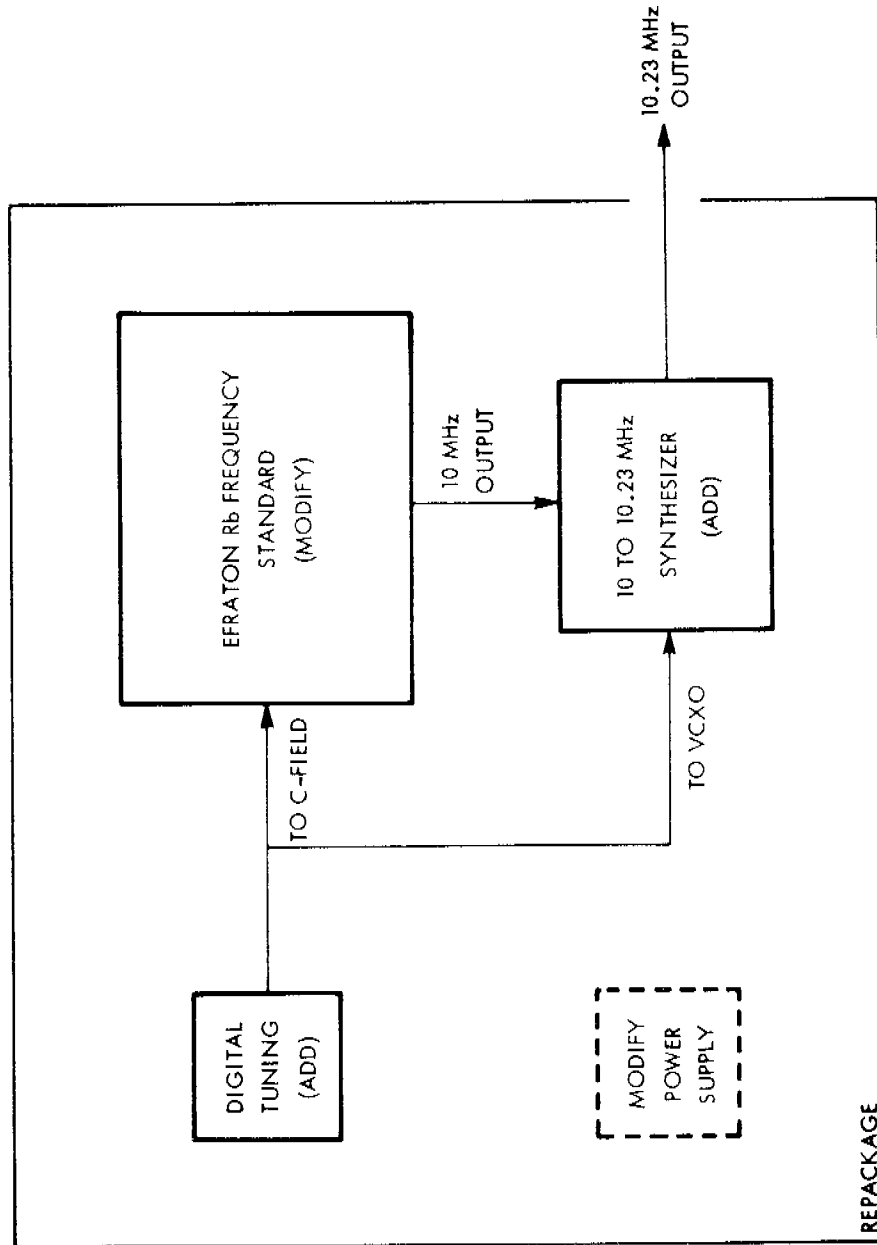

FIGURE 4 - GPS Rb CLOCK MODIFICATIONS AND ADDITIONS

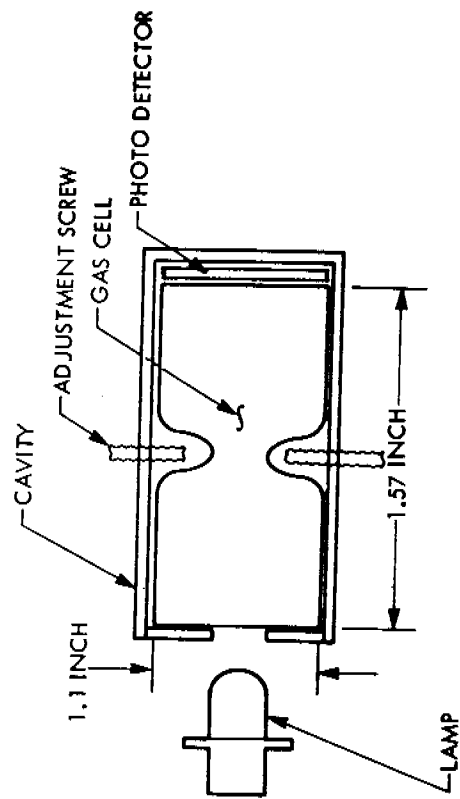

FIGURE 5 - MINIATURE PHYSICS PACKAGE

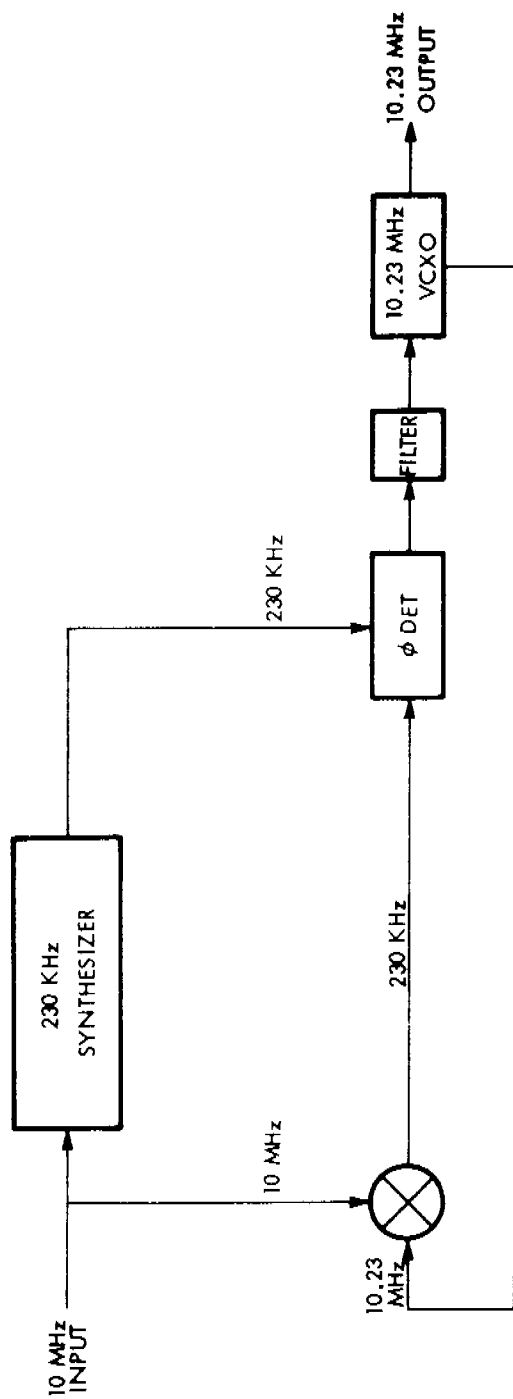

FIGURE 6 - 10.23 MHz SYNTHESIZER

DIGITAL TUNING BLOCK DIAGRAM

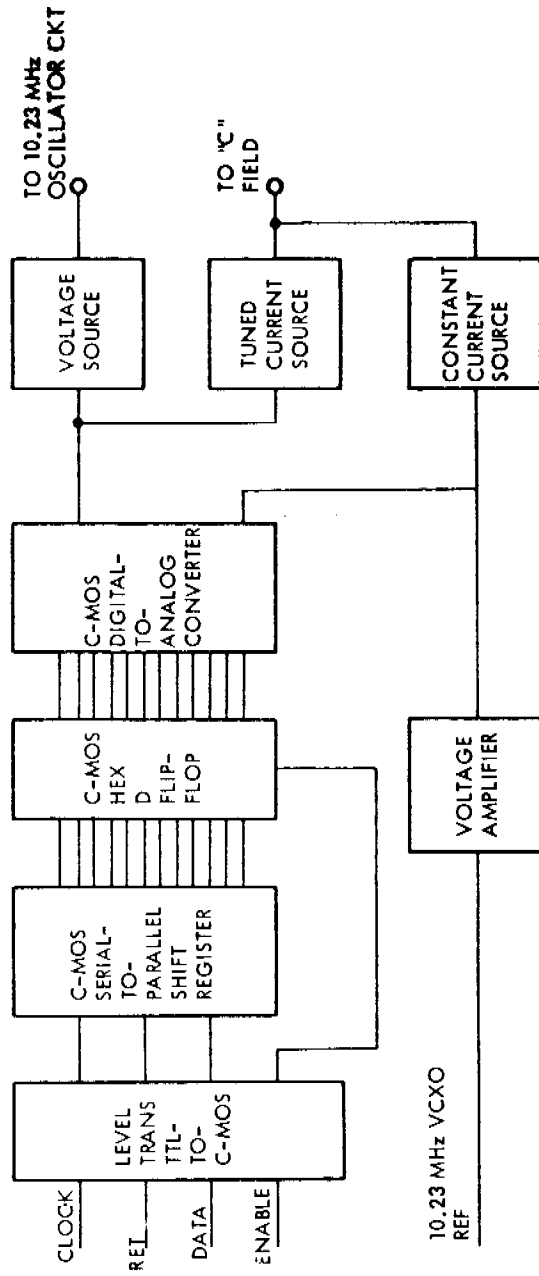

FIGURE 7 - DIGITAL TUNING BLOCK DIAGRAM

MAGNETIC SHIELDING (MUMETAL)

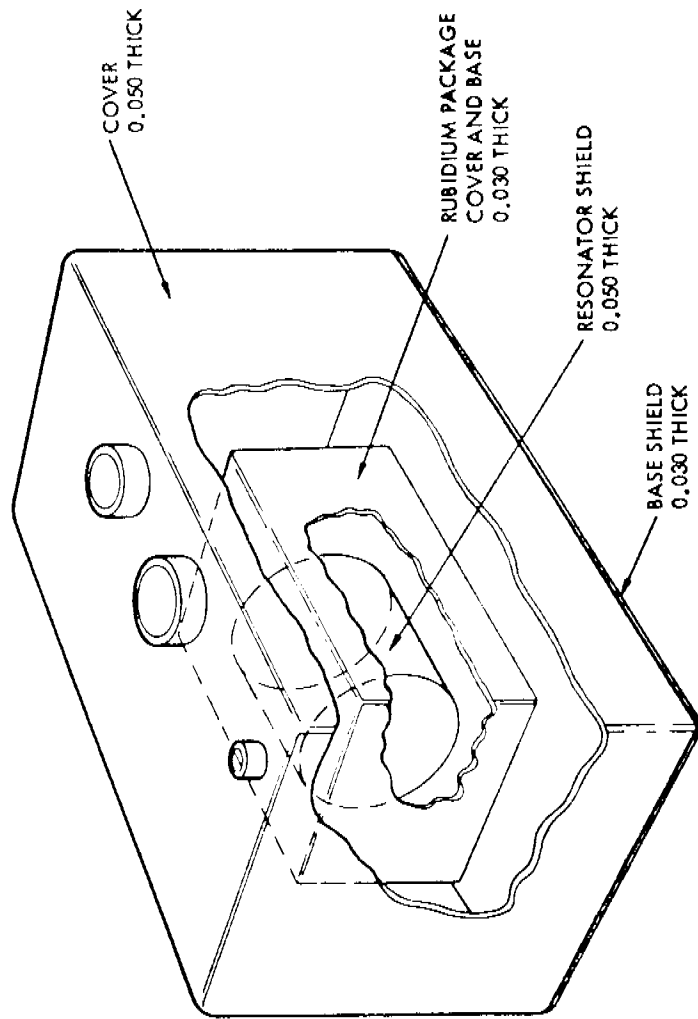

FIGURE 8 - MAGNETIC SHIELDING

RUBIDIUM PACKAGE CROSS SECTION

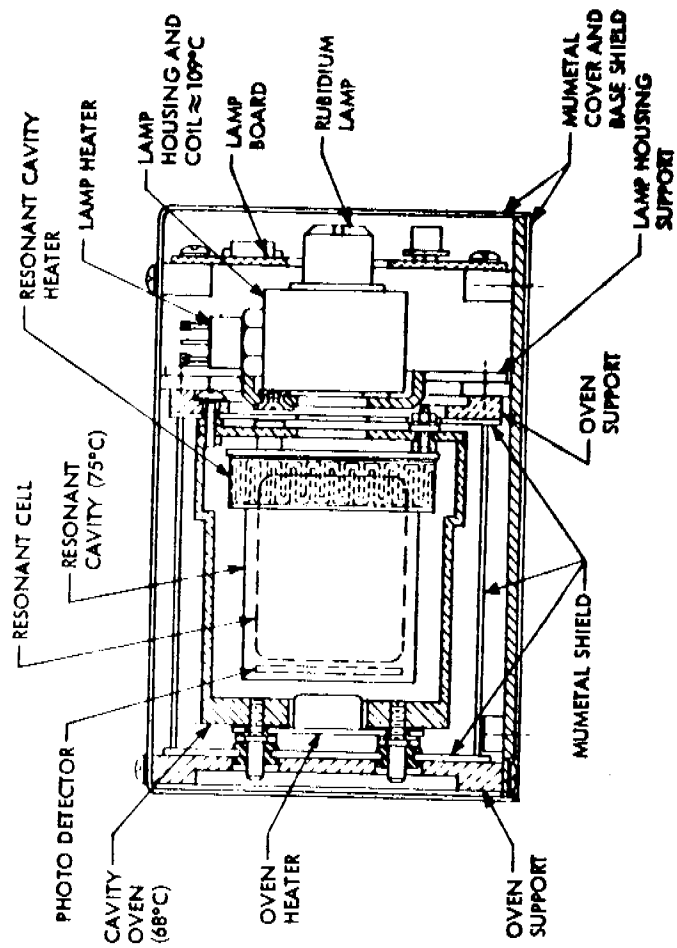

FIGURE 9 - Rb HEATERS

TYPICAL THERMAL FLOW

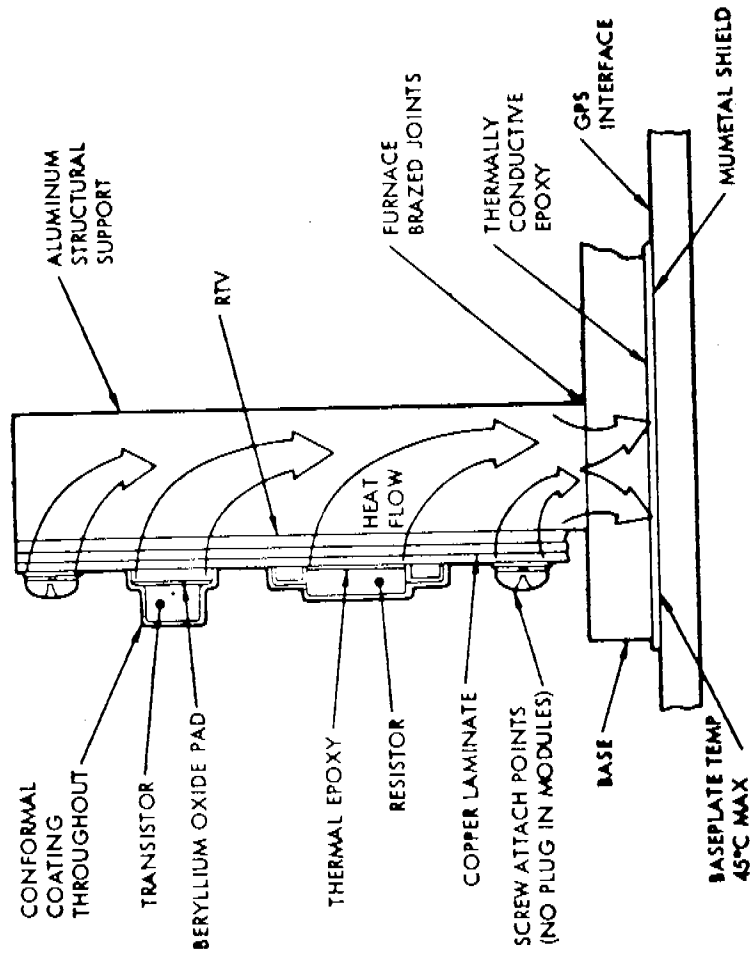

FIGURE 10 - THERMAL FLOW

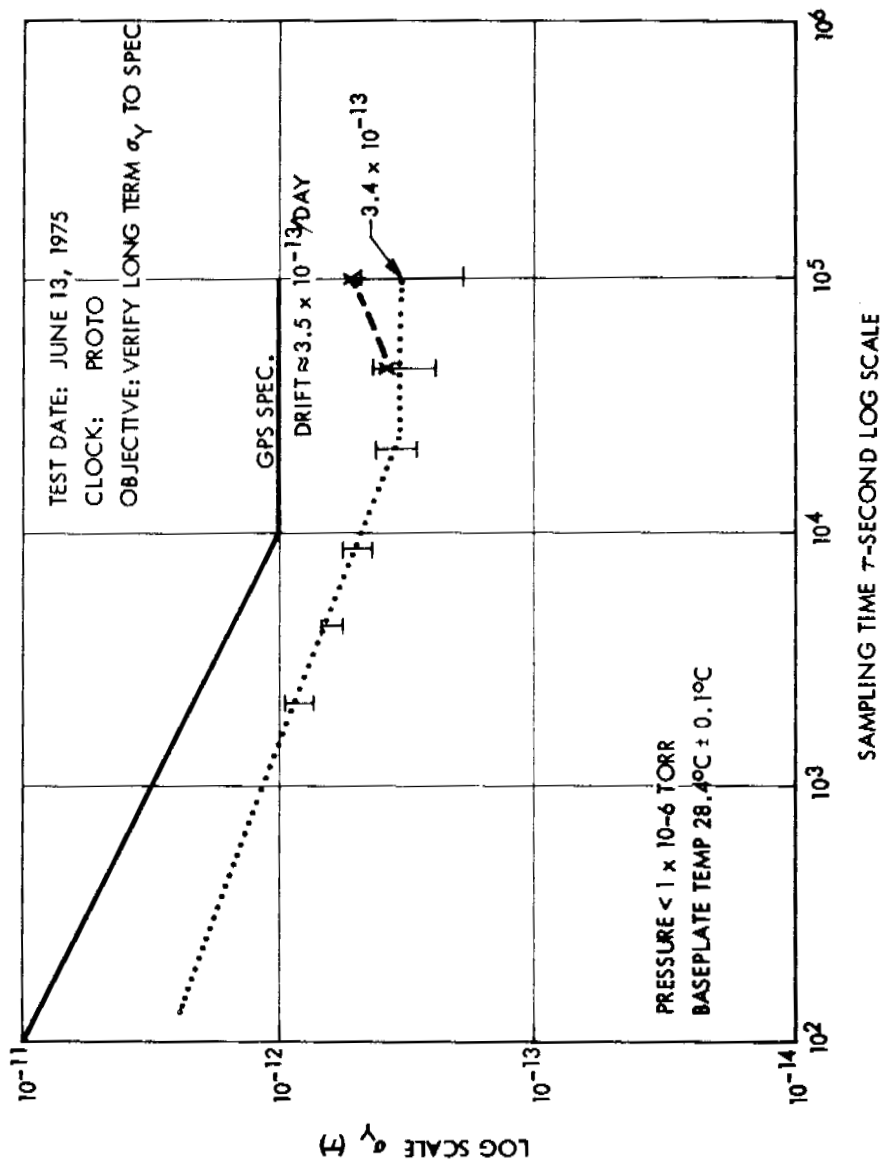

FIGURE 11 - LONG-TERM STABILITY DATA

TEST DATE: AUGUST 22, 1975 (EM1) SEPTEMBER 30, 1975 (EM2)
 CLOCK: EM1 AND EM2
 OBJECTIVE: VERIFY PHASE NOISE TO SPEC

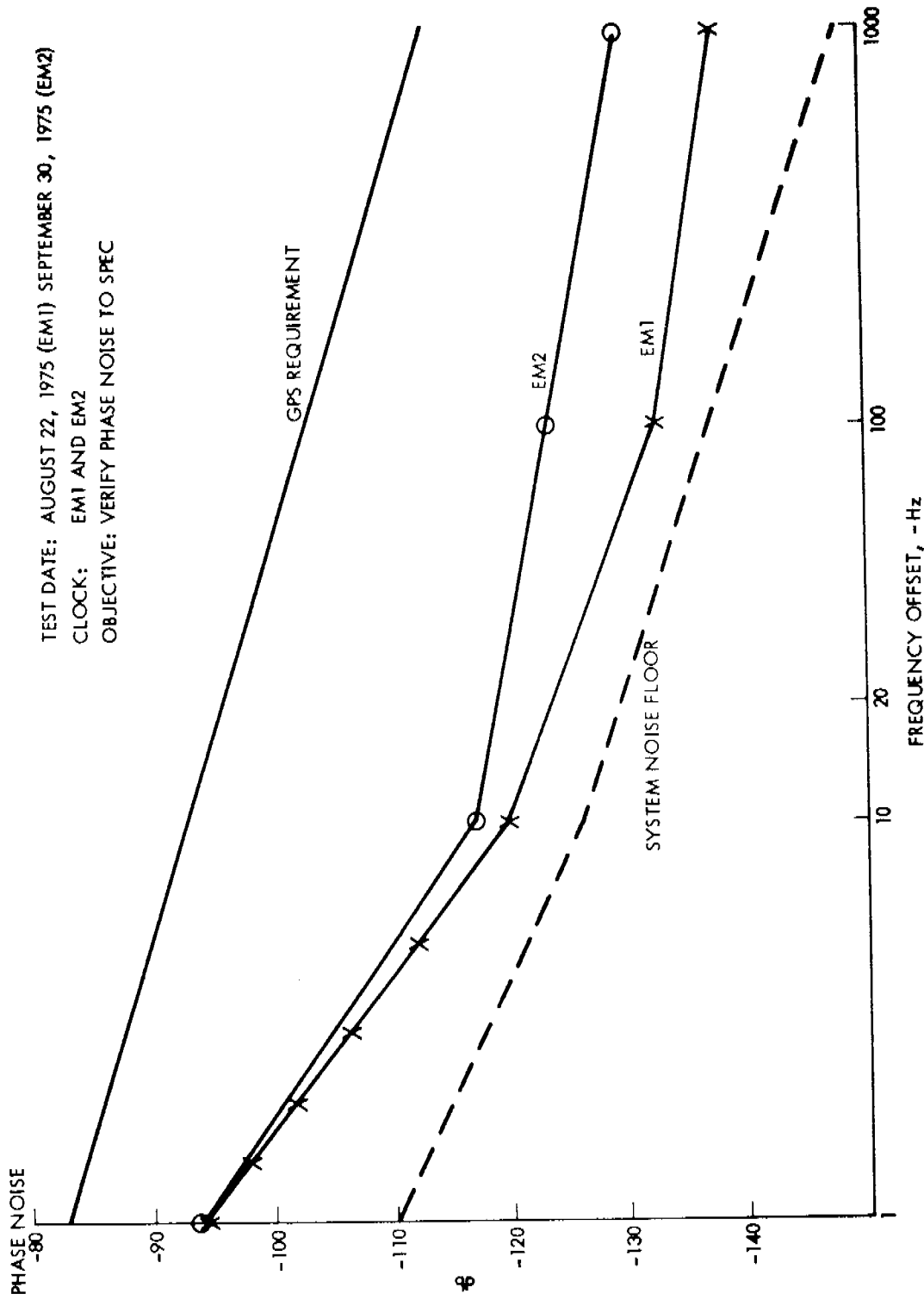

FIGURE 12 - PHASE NOISE DATA

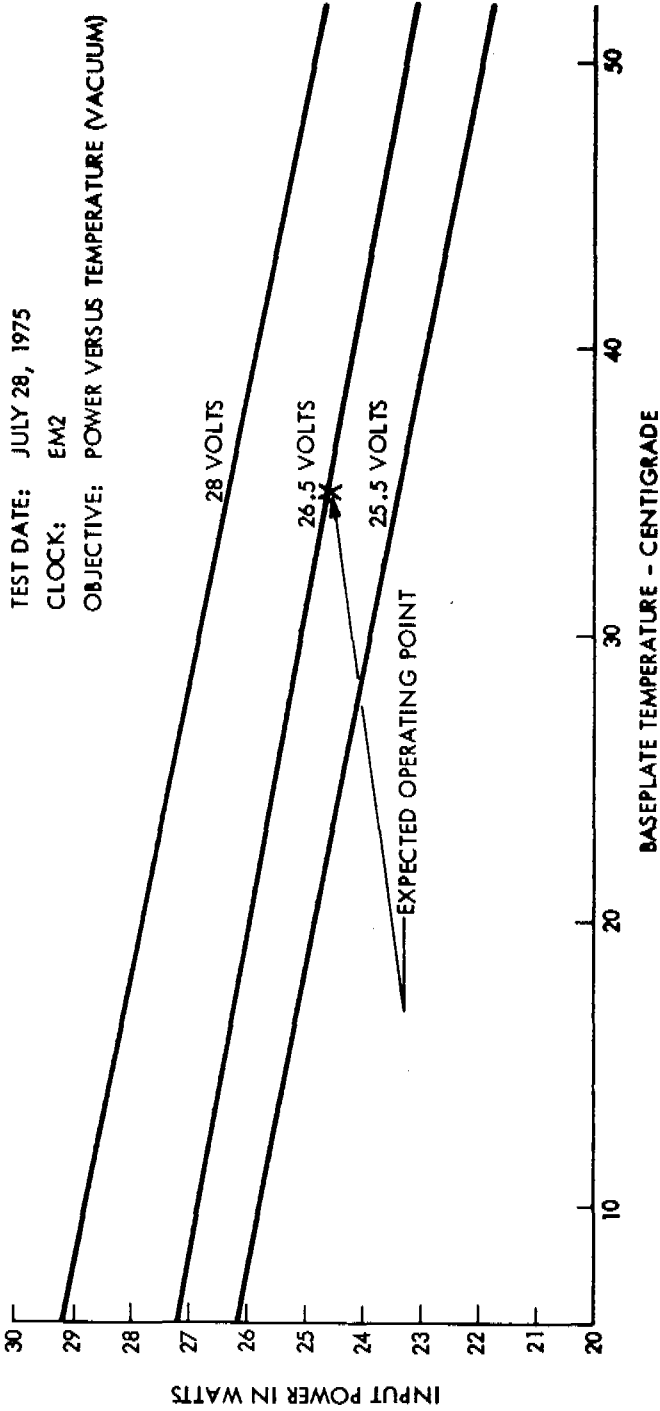

FIGURE 13 - POWER DEMAND DATA

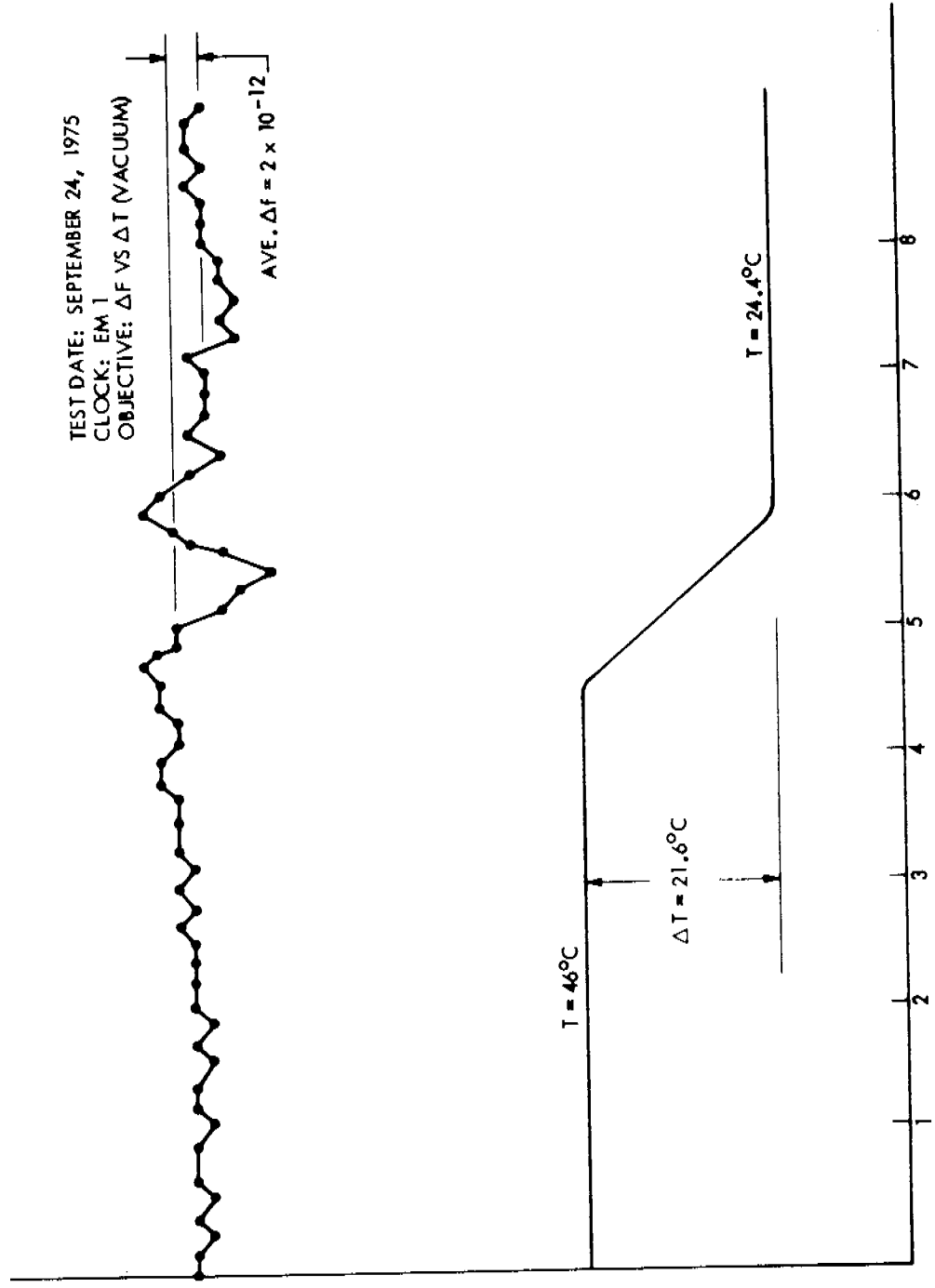

FIGURE 14 - Δf VERSUS ΔT

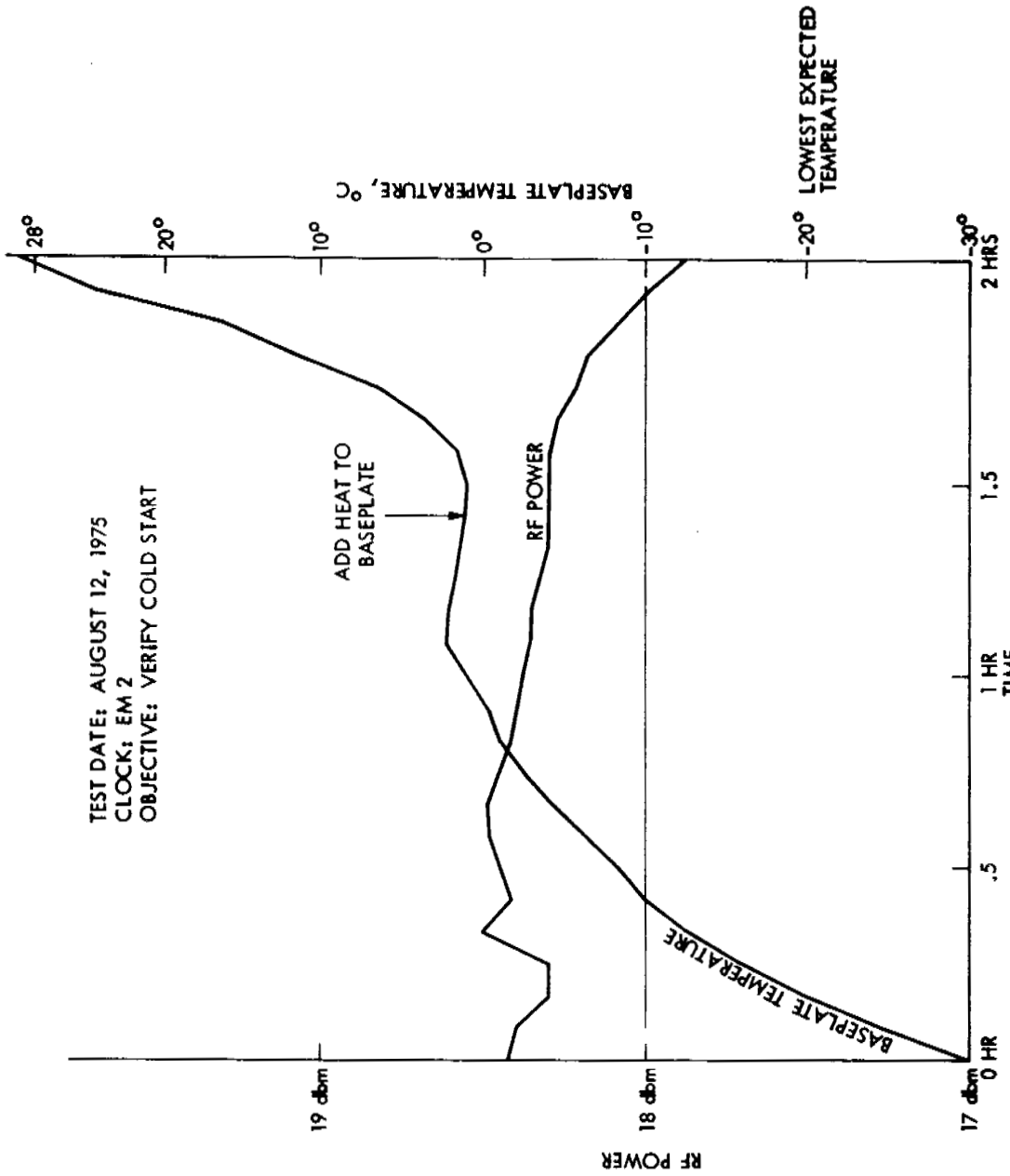

FIGURE 15 - COLD START DATA

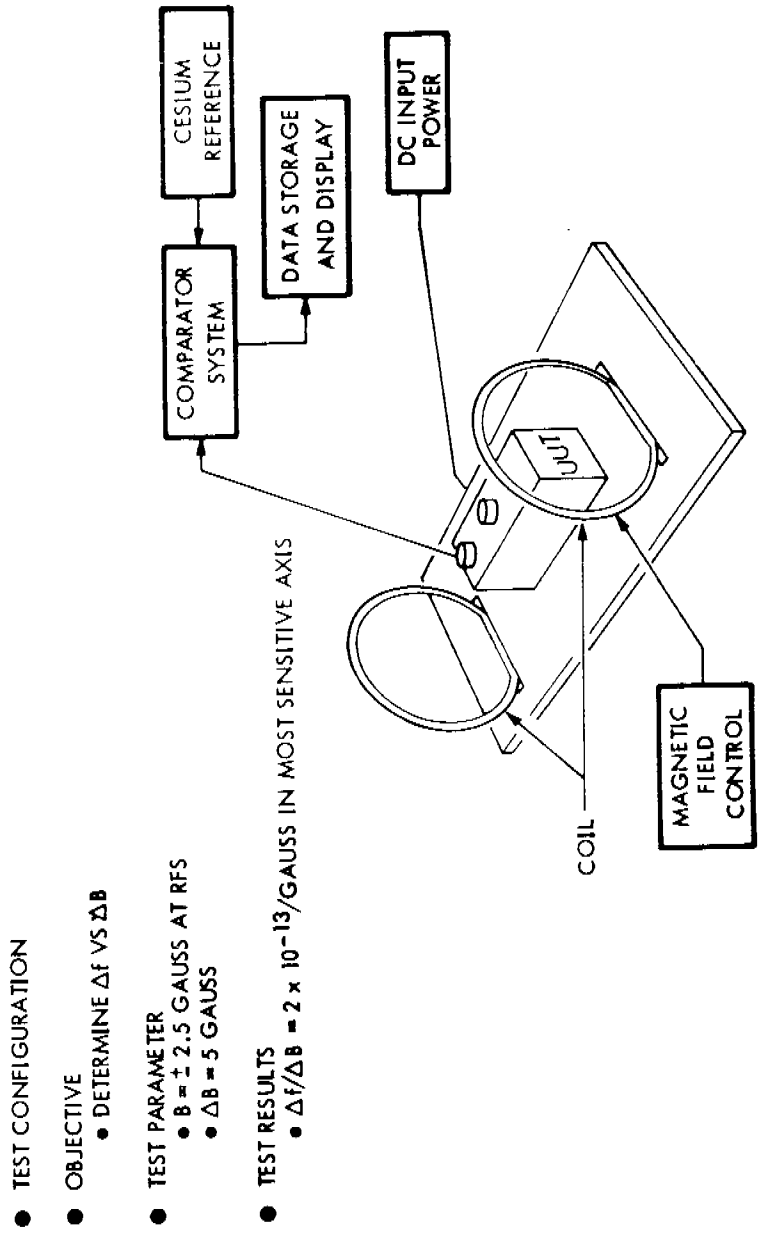

FIGURE 16 - Δf VERSUS ΔB TEST

QUESTION AND ANSWER PERIOD

MR. RUEGER:

Thank you very much. This shows an example of a very fine engineering job on a very simplified rubidium type standard.

MR. McDADE:

McDade, General Electric.

Were you required to operate during the shock and vibration tests?

MR. RINGER:

We only monitored for the presence of a signal and we monitored current input only to determine any catastrophic failures. There was no requirement during either the shock or the vibration tests to meet any kind of a frequency stability, and of course when we launch, all the clocks will be turned off.

SPEAKER:

On your frequency stability plot, could you tell me what you measured it against?

MR. RINGER:

This plot here was against Hewlett-Packard 5061 cesium. Since then we have purchased 5061, with a high performance capability and all of our further tests will be done with the high performance unit.

MR. RUEGER:

This looked a little bit more noisy than what you normally expect from a rubidium standard. Do you feel that was mostly the reference you were measuring against?

MR. RINGER:

Later data shows that we get down to our flicker floor much quicker using the 004 standard, so I think this long-term stability data here, as much as anything, was a measure of the HP cesium.