

## PRECISION TIME DISTRIBUTION WITHIN A DEEP SPACE COMMUNICATIONS COMPLEX

Jay B. Curtright

*Jet Propulsion Laboratory*

The Precision Time Distribution System (PTDS) at the Goldstone Deep Space Communications Complex is a practical application of existing technology to the solution of a local problem. The problem was to synchronize four station timing systems to a master source with a relative accuracy consistently and significantly better than 10 microseconds. The solution involved combining a precision timing source, an automatic error detection assembly and a microwave distribution network into an operational system. Upon activation of the completed PTDS two years ago, synchronization accuracy at Goldstone (two station relative) was improved by an order of magnitude. It is felt that the validation of the PTDS mechanization is now completed. Other facilities which have site dispersion and synchronization accuracy requirements similar to Goldstone may find the PTDS mechanization useful in solving their problem. At present, the two station relative synchronization accuracy at Goldstone is better than one microsecond.

The necessity for developing the PTDS evolved from the basic mission of the Goldstone Complex. Goldstone stations have been assigned the responsibility of obtaining telemetry (tracking) from deep space probes; i.e., those spacecraft which operate at distances and beyond the moon's orbit. In 1958, when the first deep space probe, Pioneer III, was tracked by Goldstone's 26-meter antenna, tracking ended when the spacecraft transmitter failed at a distance of just over 100,000 km from earth. By 1962, Goldstone tracked the first Venus probe at a range exceeding 30 million kilometers. Today, with the capability of the 64-meter Mars Station antenna, Pioneer X is being tracked at a range of over 3 AU (approximately 450 million kilometers).

During the same time frame that tracking range capability rapidly increased, other spacecraft and ground support functions had to be improved to keep pace. One of the most important improvement sequences was in the field of spacecraft control. For example, in the field of lunar exploration, the first series of probes transmitted TV pictures back to earth as the spacecraft descended toward an impact on the lunar surface at a speed over 8000 kilometer per hour. The next series of probes landed on the surface at a speed of less than 2 meters per second. After landing, the spacecraft took thousands of frames of video, performed simple chemical and mechanical analysis experiments and even lifted off the lunar surface and flew 10 feet laterally. All experiments were under direct control from earth.

In the field of planetary exploration, the first Venus probe in 1962 had a miss distance of approximately 35,000 km. The first Mars probe, launched two years later, came within approximately 9800 km of the planets surface.<sup>1</sup> By 1969, improvements in the control of spacecraft trajectory resulted in a Mars flyby within 3400 km of the surface.<sup>1</sup> In November 1971, the most recent of our Mars probes went into orbit around the planet at a planned periapsis altitude of 1650 km.<sup>2</sup> Each of the advances in control capability mentioned above required improved timing capability at the tracking stations.

The first precision timing system at Goldstone used a crystal oscillator for a source. In 1964, crystal oscillators were replaced by first generation rubidiums, and these were in turn replaced by second generation rubidiums in 1967. Over a period of four years, oscillator accuracy improved from  $1 \times 10^{-9}$  to  $1 \times 10^{-11}$ . Timing accuracy improvements, however, were not the only advancements needed to handle the increasingly more stringent mission requirements. Station timing synchronization had to be improved if the advances in oscillator accuracy were to be utilized fully.

Using HF radio, synchronization accuracy was gradually improved from a guaranteed two-station relative error of 5 milliseconds to an error of 1 millisecond. In 1967 the DSN started the Moon Bounce experiments,<sup>3</sup> which resulted in an improvement to first 20 microseconds and then 10 microseconds for two-station relative synchronization for all DSN stations around the world. The accuracy was further improved by using portable clocks but this method was extremely expensive and service was irregular. What was needed was low-cost dependable system. The PTDS project was started as a result of this requirement.

The following goals were established when the Precision Time Distribution System Project was started at the Goldstone Deep Space Communications Complex:

- Synchronize four remotely located precision timing systems to one master time source with microsecond accuracy
- Automatically monitor and record system errors for later analysis
- Use the existing communications system at Goldstone to reduce implementation costs

The first step in translating the PDTS goals into an operational system was the design and building of the Complex Microwave Timing Source (CMTS) shown in Figure 1. The CMTS contains two major subsystems, the precision timing source and the error-detection assembly. Design of both CMTS subsystems used off-the-shelf hardware to the maximum extent possible to reduce cost and construction time. A block diagram of the CMTS is shown in Figure 2.

The first block represents a commercially available cesium oscillator accurate to within one part in  $10^{11}$  or approximately 0.864 microseconds per day. The oscillator output used is 1 MHz.

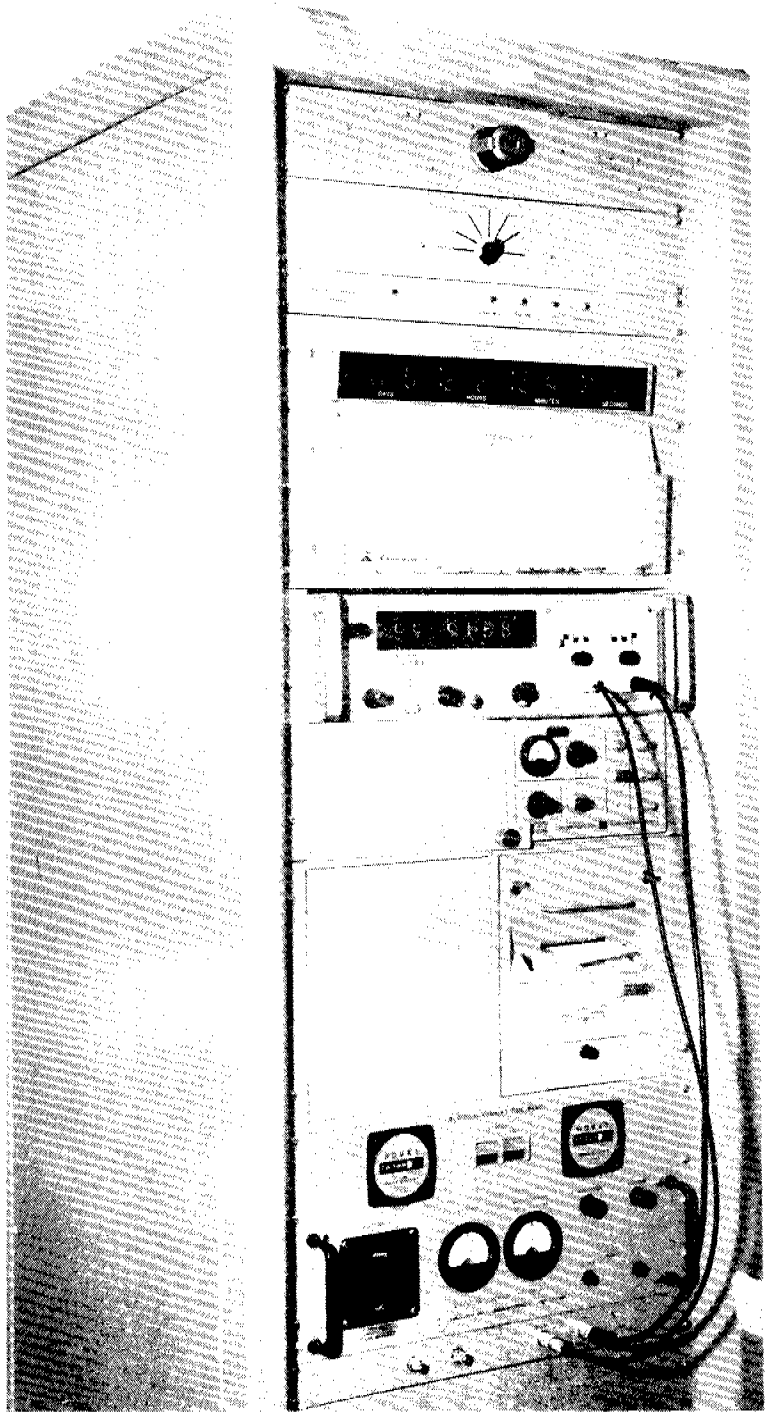

Figure 1. Complex microwave timing source assembly.

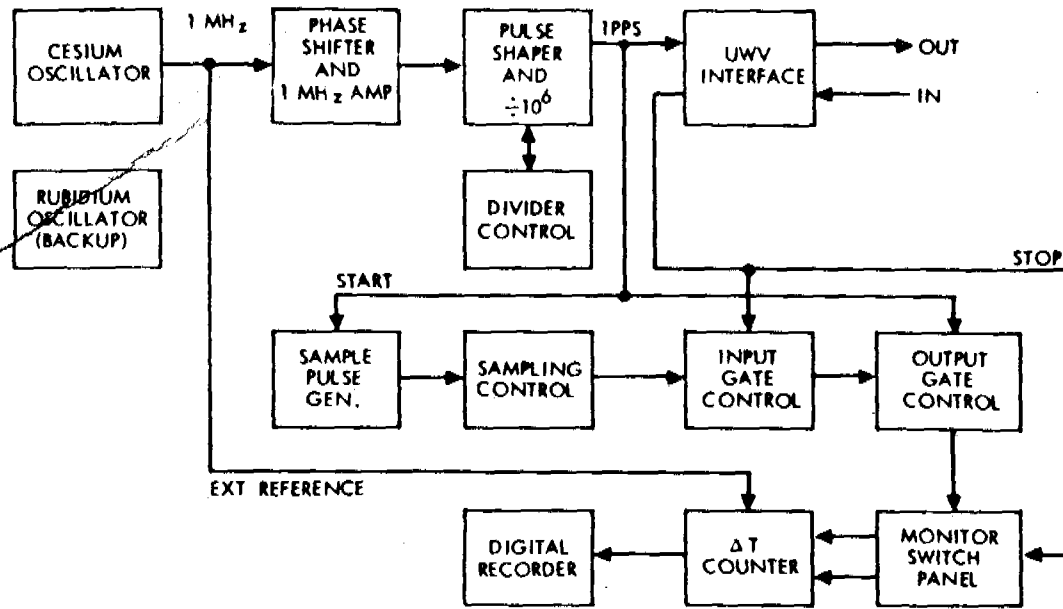

Figure 2. Complex microwave timing source block diagram.

The 1-MHz signal is passed through a continuously variable  $360^\circ$  phase shifter. The phase shifter is used to adjust the CMTS output 1 PPS within a range of 0.02 to 100 microseconds. Because of the 20-dB loss in signal level caused by the phase shifter, a tuned 1-MHz amplifier is used to boost the signal back to a level sufficiently high to drive the next stage with the required stability.

The shaper-divider block first stage is a Schmitt trigger. The 1-MPPS train of square waves out of the Schmitt trigger is coupled to standard digital divider network ( $+10^6$ ) which outputs one pulse each second; the output pulse from the divider has a 50 percent duty cycle.

The 500-millisecond pulse from the last divider stage is used in several ways. One output from the last divider is passed through a second shaper, a monostable multivibrator (one shot), to produce 50-microsecond-duration pulses spaced precisely one second apart. This 50-microsecond pulse is fed to the microwave interface, the sampling circuits and the delay counter ( $\Delta T$ ). A second output of the last divider is used to drive the divider control block. The function of the divider control is to provide the capability for delaying the output 1 PPS from 0.1 milliseconds to 1 second if required.

To be of use, the 1 PPS must be distributed to all the stations at Goldstone. Figure 3 is a map of the Goldstone Complex which shows the intersite distances and indicates the conformation of the hills surrounding each site. The hilly terrain around Goldstone site is ideal for providing the required RF isolation between sites. Several spacecraft are often tracked simultaneously by Goldstone, each by a different station. With transmitters operating at +60 to +70 dBm or more and received signal levels ranging from -140 to -170 dBm, RF isolation is a necessity. The hills surrounding Goldstone sites provide 75 dB or better RF isolation between each pair of sites.

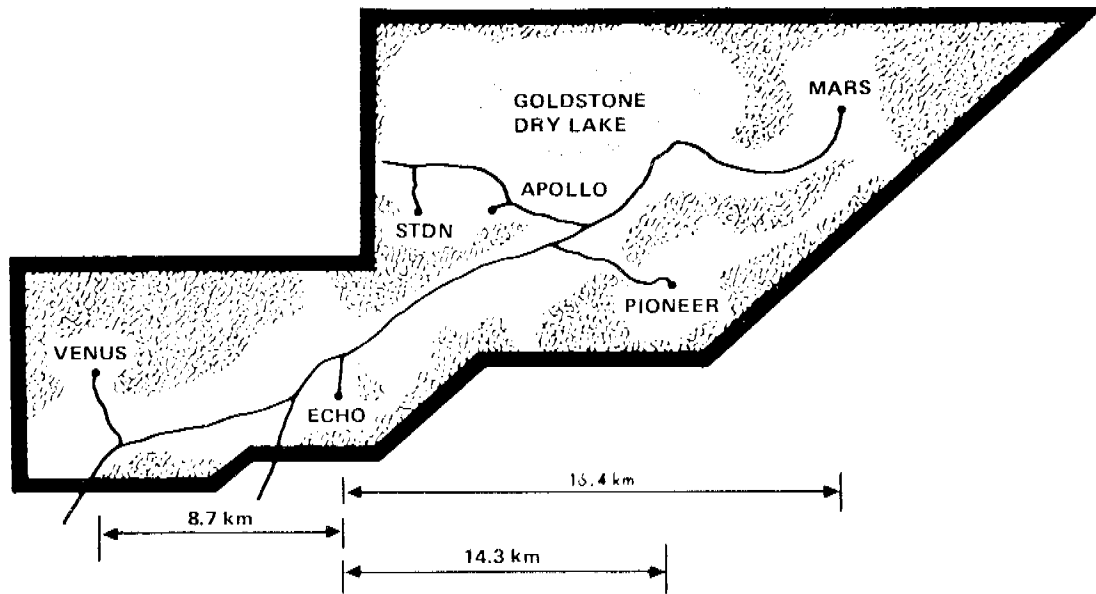

Figure 3. Goldstone complex map.

To provide the wide-bandwidth intersite communications required by Goldstone, a microwave link has been installed from the main communications center at Echo site to each of three remote sites (Figure 4). (The communications link between the Echo tracking station and the Echo site communications center uses coaxial cable since the two facilities are only

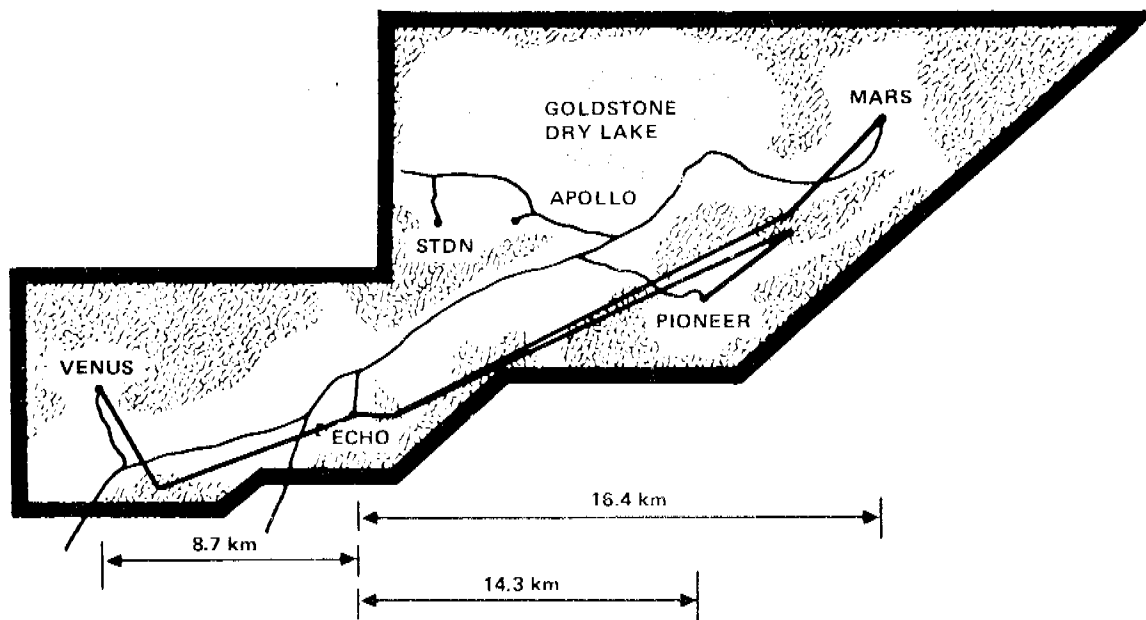

Figure 4. Goldstone complex map with microwave links shown.

about 200 meters apart via cable tunnels.) The CMTS is physically located in the communications center and is connected to the microwave equipment by short runs of 75 ohm coax.

Referring to Figure 5, the 1-PPS, 50-microsecond-duration pulse from the shaper divider is appropriately attenuated and then transmitted to the complex intersite microwave communications system. The notable items in this completely off-the-shelf communications link are the signal degradation and system drift. Figure 6 compares typical outgoing and return pulses; the outgoing pulse was taken from the output of the line driver amplifier of one station channel and the return pulse was taken from the same station return channel video amplifier. For basebands frequencies above 2.5 MHz the rise time of the return signal, between 10 percent and 90 percent of the slope, was approximately 0.4 microseconds, which was quite adequate, as compared to the slightly less than 0.2 microseconds rise time for the input pulse. Both pulses are extremely stable and exhibit almost undetectable jitter. Early in the project basebands above and below 2.5 MHz were tried. It was found that baseband frequencies above 2.5 MHz passed the pulse equally well but significant degradation in rise time occurred below a frequency of 2.5 MHz.

During this project, careful measurements were made of system drift as evidenced by variations in recorded round-trip delay times. Drifts of up to  $\pm 0.2$  microseconds were noted on all three microwave links. Since the changes were somewhat cyclic, it is believed probable

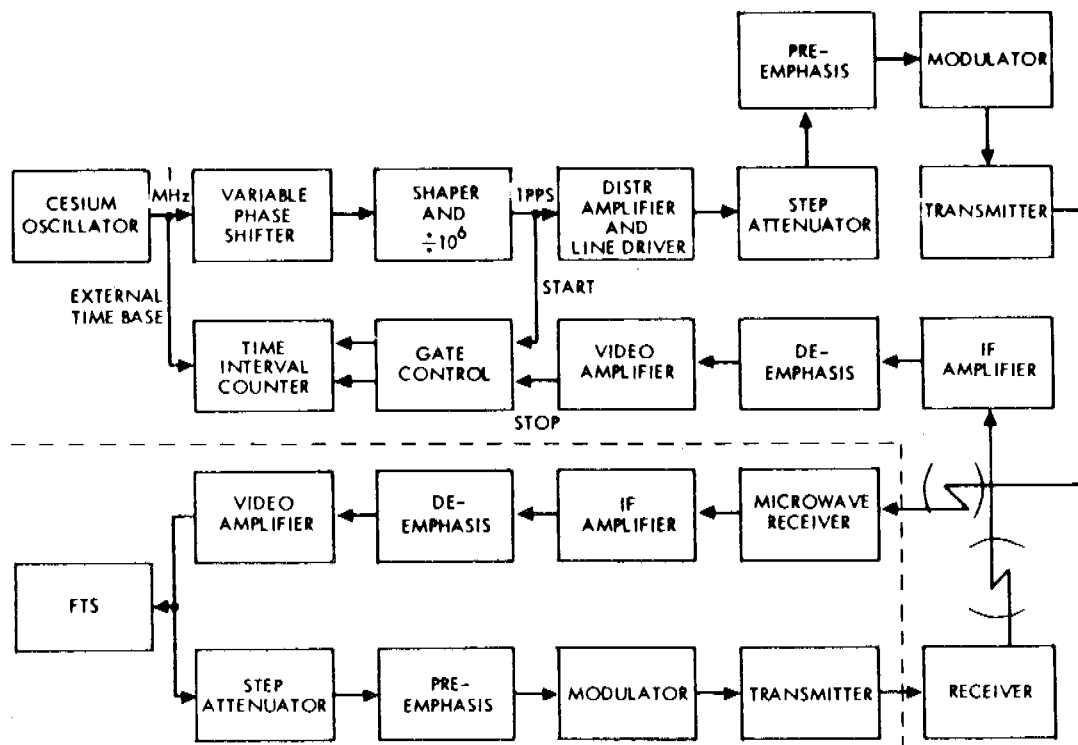

Figure 5. Precision time distribution system block diagram (1 channel).

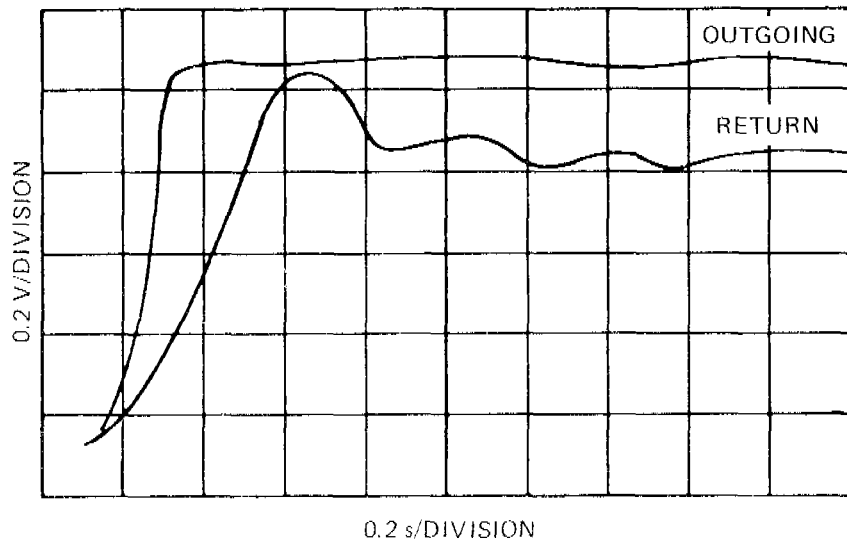

Figure 6. Microwave link waveform comparison.

that changing weather conditions were the prime cause of the drift. Cyclic variations of  $20^{\circ}\text{C}$  or greater than 40 percent relative humidity in 24 hours are, of course, not uncommon in the desert. In addition, during some windstorms, very large amounts of dust occlude the propagation path of the microwave link. Figure 7 is a plot of the drift of one channel of microwave over a period of 10 days. The diurnal cycling of the system is, of course, quite obvious. However, the causes of the longer period drift envelope, as evidenced by the 2-1/2 day cycle in the center of the plot, have not been fully determined. Investigation of system drift cycles is continuing. The correction of these drift problems is not particularly pressing at this time. Total excursion of the drift is less than 70 nanoseconds, which is more than an order of magnitude better than is presently required.

Referring again to Figure 2, the 1 PPS is also used to drive the error detection sampling logic of the system and provide the start pulse to the  $\Delta T$  counter. First a combination of divider circuits is used to generate the several time periods involved in the sampling process. Pulse

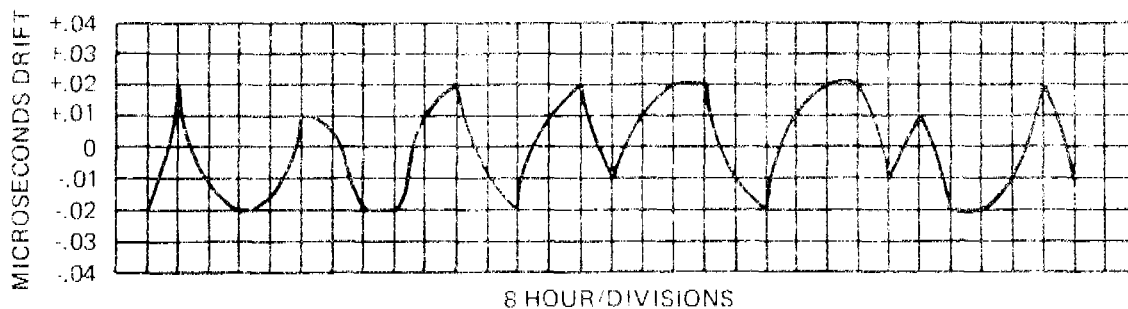

Figure 7. Microwave channel drift; ten-day period.

outputs for 1, 2, 4, and 64 minutes are used in the control logic. Each 64 minutes the prime sampling enable signal is generated, starting the sequence. Through the control of a series of coincidence gates, the round-trip delay time of each of the four stations is sampled in sequence and printed out 30 times in a 30-second period. The CMTS 1 PPS starts each sample count in the  $\Delta T$  counter, and the 1 PPS returned from the station stops the sample. The sequence is completely automatic. No identification is used to "tag" the counter print-outs since the sampling sequence is always the same and the wide disparity between round-trip times permits easy identification. Table 1 gives the time frames and approximate round-trip delay times for each of the four stations monitored. A complete schematic of the sampling control circuits and the precision timing circuits is shown in Figure 8 for readers who wish to study the CMTS in more detail.

Table 1  
Time Frames and Delay Times.

Station	Time Frame	Delay* ( $\mu s$ )
Pioneer	T0-T30	94
Echo	T60-T90	3.5
Venus	T120-T150	58
Mars	T180-T210	112

\*Delays are not actually figures, but are for use in identifying the stations from which samples are taken.

One feature of the PTDS that has not been previously mentioned is the clock reference for the cesium oscillator. The DSN Reference Standards Laboratory (RSL) clock located at Echo site is the standard used by all stations in the worldwide network. The RSL clock is continually maintained at within  $\pm 2$  microseconds of the National Bureau of Standards Clock-8.

The CMTS assembly receives the timing signal of the RSL clock by coaxial cable. The RSL also supplies a set of predictions of their best estimate of the difference between the NBS-8 and the RSL clock. By comparing the RSL daily predictions with the actual difference between the RSL clock and the CMTS oscillator, Goldstone has been able to maintain the CMTS at within  $\pm 2$  microseconds of NBS-8. Thus, for the past two years, Goldstone stations timing accuracy has been maintained at within  $\pm 3$  microseconds of NBS-8 and at better than one microsecond synchronization accuracy from station to station.



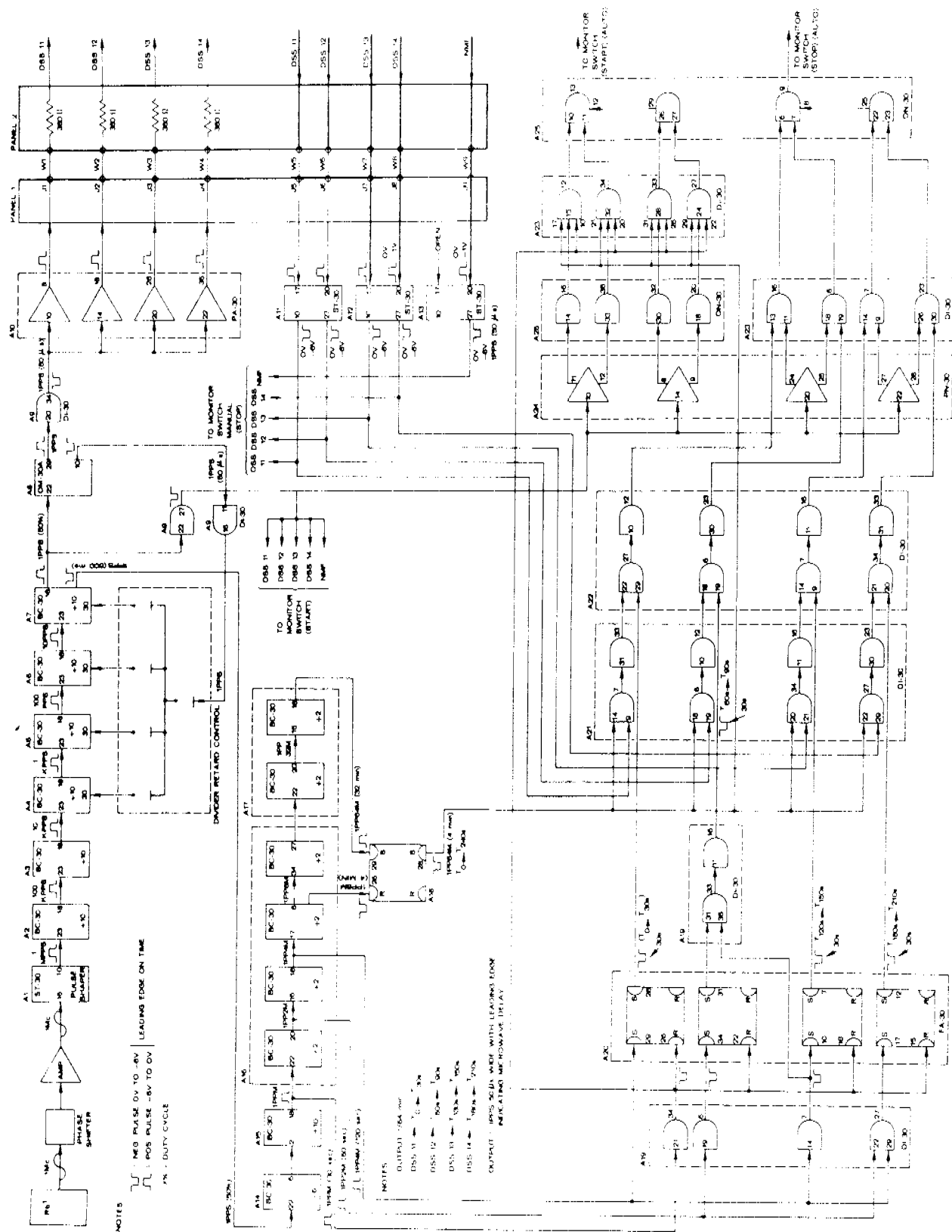

Figure 8. Complex microwave timing source logic diagram.

## REFERENCES

1. NASA Pocket Statistics History, Program and Special Reports Division, Executive Secretariat, National Aeronautics and Space Administration, Washington, D.C., pp. A 28, A 35, A 62, July 1972.
2. "Mariner Mars 1971 Status Bulletin No. 22," JPL Internal Document, Jet Propulsion Laboratory, Pasadena, Calif., January 12, 1972.
3. W. H. Higa, "Time Synchronization via Lunar Radar," IEEE Proceedings, vol. 60, No. 5. pp. 552-557, May 1972.