

SUPERIMPOSING LOW-PHASE-NOISE, LOW-DRIFT,
INSTRUMENTATION TECHNIQUES ON RF DESIGN*

C. M. FELTON

Time and Frequency Division
National Institute of Standards and Technology
325 Broadway, Boulder, CO 80303

Abstract

The information required to do good low-phase-noise design is, for the most part, already in the literature under different titles. Low-noise audio design is concerned with optimizing amplitude signal-to-noise ratio. Instrumentation amplifier design isolates the desired signal, using bridge configurations, (control of common mode rejection ratio (CMRR) and power supply rejection ratio (PSRR)) from interfering noise and line harmonics.[1,2,3] Concerns with operating point stability at the microvolt level lead to awareness of dielectric quality, thermal stability, and bias balance requirements. At a large laboratory there are numerous sources of electromagnetic interference. Switching power supplies, clock and computer radiation, motor start-up surges, and fluorescent light spikes are as hostile an electromagnetic environment as a power utility substation. Critical applications require that such interference be considered in the basic circuit design. A balanced circuit resembles (or can be successfully encouraged to do so by the designer) a parallel, two wire transmission line, providing for rejection of external electromagnetic noise.

The focus of this paper is integrating these considerations into basic designs. A radio frequency (RF) isolation amplifier will be used to illustrate the concepts. I will discuss component selection and circuit details of the completed device and show how these affect both AM and phase noise (PM) performance.

RF design in a phase noise context

It is important to have full-time access to a relatively low-noise source (crystal oscillator), and equipment to measure amplitude and phase noise. Good low-amplitude noise design is not the same as low phase-noise design, although the two are related. To aid my own visualization, I think of phase modulation occurring in series and shunt modes. (Figure 1)

* Contribution of the U.S. Government, not subject to copyright.

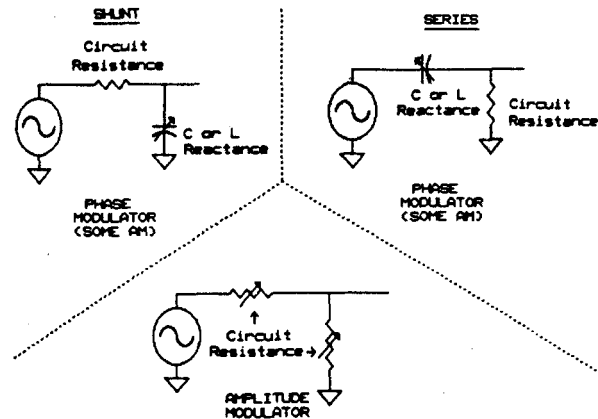

Figure 1. This is an aid to visualization. In a practical circuit, all 3 of these will be occurring simultaneously to one degree or another.

To the extent that a circuit element or stage is nonlinear with frequency, that stage forces a phase shift in whatever signal passes through it. Baseband noise and thermal drift, present with the desired signal, will act as variables in the modulators (Fig. 1) and therefore modulate the desired signal.

Standard microwave radio frequency (RF) amplifier designs, (as presented by computers – variations on the microstrip matched, grounded emitter, capacitance coupled, single ended (class A or C) configuration), present their basic characteristics as reasons for me to suspect them of being poor phase noise performers.

High-Q (> 1) resonant circuitry is undesirable because a major mechanism of phase modulation is the reactive slope at any one point. The steeper the slope is, the higher the modulation efficiency and the higher the temperature coefficient.

Some form of emitter or source degeneration is crucial to obtaining low phase-noise performance. Resistance, emitter to ground, improves operating point or baseband stability and improves signal linearity. Thermal instability is a major contributor to low frequency noise,

below a few hertz, and amplitude nonlinearity reduces power supply rejection as well as introducing an unstable element into the modulators (Fig. 1).

Bipolar transistors have more gain at low frequencies than at radio frequencies. Capacitively coupled bipolar amplifiers can accumulate baseband noise faster than desired signal, with each succeeding stage effecting amplitude modulation (AM) to phase modulation (PM) conversion of the amplified baseband noise.

The single-ended amplifier stage has no low frequency power supply noise rejection, and no common-mode noise rejection (Fig. 5). This is because signal currents share the ground return with operating (B+) currents and input-to-output signal-ground currents (assuming capacitor coupling).

Transmission line transformers are a good solution for interstage coupling at radio frequencies. When impedance matched and compensated, these devices can give a flat reactive slope around design center, while at the same time, effect impedance transformation and phase inversion, necessary for balanced amplification. Because of their transmission line construction, they also cancel external field pickup and radiation.[4,5]

The balanced amplifier configuration allows use of emitter/source-coupled pairs, the basic instrumentation amplifier form which provides isolation from power supply rail noise and common mode ground-plane noise.[2,3] The transformer coupled push-pull pair also allows:

- Direct current paralleling of devices to reduce device generated noise.
- Common mode isolation from input to output.
- Low amplitude-distortion for a given power dissipation.
- Cancellation of even order harmonics.
- Circuit stray capacitances are in series in a push-pull stage and not direct shunts to ground. This allows wider bandwidth for a given impedance level.
- Relatively high reverse isolation from output to input.
- A large resistance or constant current source can be used in the emitter circuit without appearing in the signal path.

Ground path continuity and mass are so important that they almost cannot be used for design trade-off. When we start looking as low as 170 dB below the signal, ground-path resistance and reactance, adequate for lesser dynamic ranges, can allow development of common-mode noise and

signals that will compromise the noise-floor. While a balanced RF amplifier can achieve a useful degree of common-mode isolation, this reduces, but does not eliminate, requirements for control of common-mode signals and noise.

Ohm's law ($E=IR$) describes what happens. I will expand that a little for these purposes:

$$\frac{(\text{CMRR})(E)}{\text{Circuit gain}} = I \times \left(\frac{\text{common-mode ground path}}{\text{resistance} + \text{reactance}} \right)$$

where

E = acceptable limit of interfering signal or desired circuit noise floor

I = common mode noise current that will produce E

CMRR = In this case, this is a complex term including, but not necessarily dominated by, a calculated figure. The amplifier physical ground path, as a percentage of the overall ground path (the path along which common mode signals are conducted), and the angular orientation of that amplifier ground path relative to noise current flow, will determine the percentage of noise signals generated by common mode currents which will be injected into the amplifier. Then, the amplifier's CMRR (if any) will act to isolate the desired signal from this resultant noise. A real number for total CMRR, in this case, is more accurately arrived at experimentally.

Circuit requirements will fix the noise floor and circuit gain. Control of environment will reduce interfering signals to some unavoidable minimum. At radio frequencies, common-mode isolation is limited by relatively unstable stray reactances. After the other terms are optimized, what is left to manipulate is the ground path characteristic.

For example, take three sets of points 5.08 cm (2 inches) apart. One set is connected by a printed circuit trace 1.575 mm (0.062 inches) wide. Another is connected by copper wire of 0.635mm (0.025 inches, #22) diameter. A third set is centrally located on the unetched copper foil of a 7.62cm (3 inch) by 12.7 cm (5 inch) printed circuit card. 100mA of direct current and then 4.5mA RMS at 10MHz was applied between the three sets of printed circuit board pads to obtain approximate values for resistance and reactance.

Conclusive RF measurements across 5.08 cm (2 inches) of a continuous copper ground plane were not

possible in the time available. All indications were that the reactance is very small, approximately 0.1 ohm or less at 10MHz. Experimental estimates of the trace and wire over ground plane were not so difficult because they are much larger - 1.5 ohms and 0.5 ohm at 10MHz. Estimates of the D.C. resistances are 0.0006 ohm for the ground plane, 0.0015 ohm for the wire, and 0.015 ohm for the trace. This is a relatively large trace.

The difficulty of breadboarding these measurements puts these figures in the -50% to +100% range of error. They do, however, give a good indication of the large difference between a single conductor and the continuous ground plane when it comes to controlling common-mode noise.

For example, you've got a single ended amplifier with a gain of X10, and a maximum allowable interfering signal of 1uV. If you have been able to get the current of common mode line harmonics down to 0.1mA, the required total ground plane resistance would be 0.001 ohms.

Active Device Considerations

Available devices require some form of paralleling within the device structure to get a low noise-corner. Large gate area in junction field effect transistors (J-FET) produces the lowest noise but the highest capacitance, limiting frequency response.[3] The U310 FET die is a good compromise between noise and speed. The multiple emitter site, ballasted bipolar transistor configuration, desirable for stability at microwave frequencies, can also be stable and exhibit low noise at baseband.

Since high-Q circuitry will produce a high AM to PM conversion factor and phase/temperature instability, devices with low interelectrode stray capacitances are desirable at RF. Small capacitance values can be absorbed into the compensating capacitance of the transmission line transformers allowing for the flattest possible response.[4] Moderate to low operating impedances are desirable because less inductance is required for a given frequency response in transformers. I have experienced trouble obtaining flat high frequency response at the higher impedances above 400 Ω . The lower the circuit impedance, the less the effect of the unavoidable stray capacitive reactance also. Strays are by their nature unpredictable and unstable.

Junction Field Effect Transistors are limited to the common-gate configuration to keep impedances as low as practical and eliminate adverse effects of reverse transfer capacitance. Microwave bipolar transistors are most useful

in the common emitter, emitter-coupled pair configuration now, but better low impedance transformer designs may extend bipolar possibilities by allowing efficient use of common base configurations.

Capacitor Considerations

- Capacitance temperature stability
- Dielectric loss temperature stability,
- Absorption (environmental stability), aging, internal and package mechanical stability (microphonics)
- Capacitor value reactance at frequency of interest, case and lead reactance
- Capacitor reactance at baseband
- For use in signal path, stacked foil Mylar, wound foil Mylar and polypropylene are low inductance and high dielectric quality
- Use solid tantalum only where an electrolytic is required

Inductor Considerations

- Inductance temperature stability
- Control of radiation and rejection of external magnetic fields
- Microphonics
- Resonance effects at signal center frequency and baseband
- The ferrite loaded transmission line transformer optimally applied resolves most inductor considerations and also allows implementation of a balanced, non-resonant RF amplifier.

Resistors

- Because of their superior noise and thermal performance, I use 1% metal film, conservatively rated resistors everywhere.

Power Supply Considerations

Three-terminal regulator broadband-noise output is approximately -135 dBV/Hz as viewed on an audio spectrum analyzer out to 400 kHz. Depending on the power supply rejection ratio and the AM to PM conversion factor of the circuit in question, this could easily set the broadband phase noise floor. Single-ended circuitry almost does not have a PSRR. Class A and C amplifiers and most forms of logic are offenders in this way. (Figure 5) If the power supply situation can accommodate the additional voltage drop and power dissipation, and if the remaining close-in noise is not a problem, a simple resistor/capacitor

(R/C) filter will reduce rail AM noise below where it will be a major contributor to circuit phase noise performance. (Figure 2)

Audio noise at LM317 output (+15V)

1Hz	-112dBV/Hz
10	-118
100	-131
1000	-134
10000	-134
25000	-134

Audio noise after RC filter (+12V)

1Hz	-112dBV/Hz
10	-121
100	-148
1000	-166 M
10000	-170 M
25000	-169 M

M is measurement system limited.

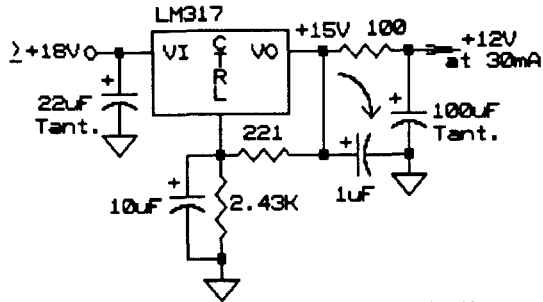

This configuration is used with the FET iso-amplifier shown in fig. 6

Figure 2.

When output shunt capacitance approaches some fraction of input capacitance or there is reactance on one of the legs, three-terminal regulators can oscillate. They are, after all, gain blocks. This oscillation may not be obvious or even visible with an oscilloscope. But it will get into sensitive circuitry and cause increased noise, instability, and even intermittent thermal shut-down of the regulator. If phase noise is a major consideration, a better solution is to build a discrete regulator using a precision reference, low-noise operational amplifier, and a pass device. This can produce a power supply noise floor of approximately -160 dBV/Hz, but even here, the most critical situations will require some kind of postfiltering. (Figure 3 and Figure 4)

Audio noise at output (+12V at 30 mA.)

1Hz	-134dBV/Hz
10	-150
100	-160
1000	-161
10000	-161
25000	-161

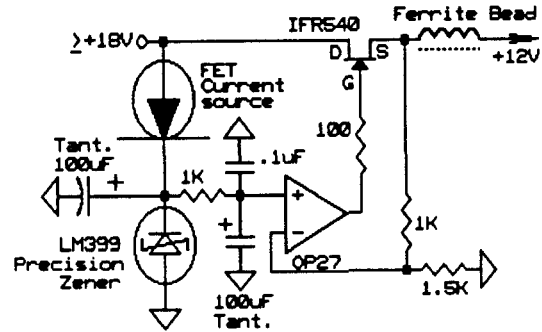

Figure 3.

Simple additional active low-pass filtering can be added after the regulator when current or close-in noise specifications require. This circuit also isolates the regulator from any large shunt capacitor required for a single-ended stage. (Figure 4)

IFR540 MOSFET follower

1 Hz	-126 dBV/ Hz
10	-137
100	-147
1000	-163
10000	-170 M
25000	-169 M

+ Source IFR540 ≈1-4V drop

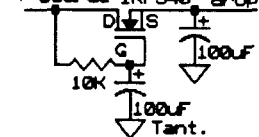

2N3904 discrete darlington

1 Hz	-127 dBV/ Hz
10	-146
100	-158
1000	-168 M
10000	-170 M
25000	-169 M

+ Source 2N3904 ≈1.4V drop

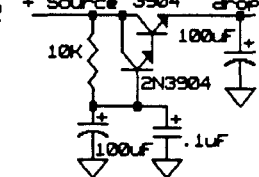

M is measurement system limited

J105 JFET Regulator

1 Hz	-128 dBV/ Hz
10	-136
100	-155
1000	-169 M
10000	-170 M
25000	-169 M

+ Source J105 Output ≈13.5V

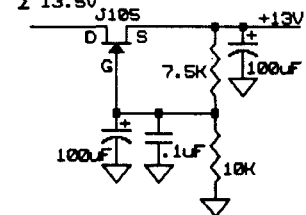

Low Current, Low Noise Programmable Regulator

Figure 4. Two low noise clean-up followers and one regulator. Noise measured at 30 mA current.

Baseband resonances in the B+ decoupling networks can generate noise peaks. Common-mode or bias currents circulate equally in the active device, decoupling circuitry, power supply, and ground path. These are all in series for low-frequency noise. Capacitors used as high frequency ground returns and filters will be completely transparent at very low frequencies.

(Figure 5)

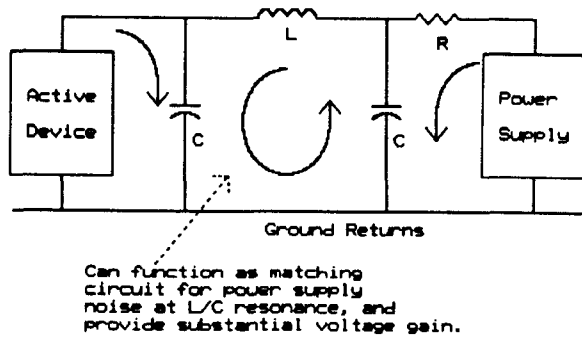

Figure 5.

Figure 6 is a representation of a noise floor peak initially observed during phase noise testing of a circuit. The same peak was observed on the power supply rail. Eliminating an accidental resonance in decoupling circuitry removed both peaks.

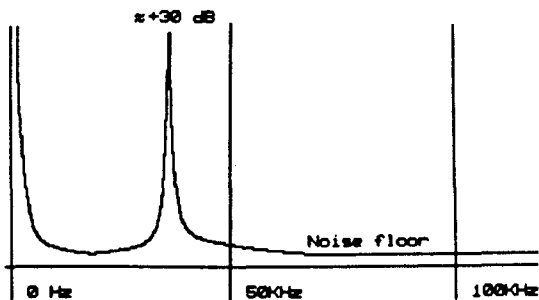

Figure 6.

RF Isolation Amplifier

Here is an isolation amplifier for the lower clock frequencies (1 to 10MHz) using readily available commercial components. (Figure 7)

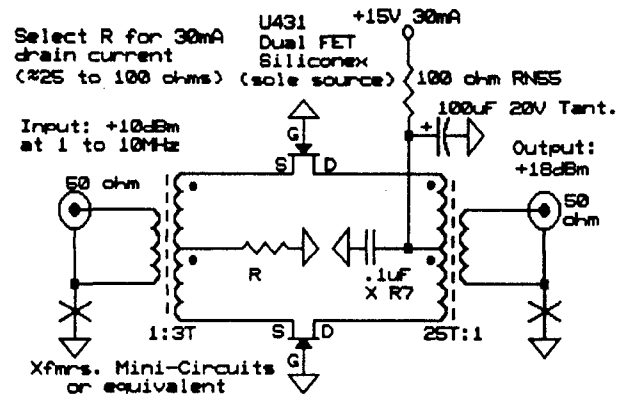

Figure 7

Input and output need not be ground referred; this allows very high input-to-output common-mode isolation.

Substituting optimized custom transformers for the commercial units can substantially expand the bandwidth.

CONSIDERATIONS: (Figure 7)

- Gain: +8dB, 1 to 12MHz (-1dB, 80kHz to 15 MHz; -3dB, 50kHz to 26MHz)
- Reverse isolation: ≥ 34 dB, 10kHz to 670MHz
- PSRR: for drain volts, +1V, (at output 18dBm) $\leq +1$ MV
- Input level for compression at 10MHz: +11dBm/0.1dB, +16dBm/1dB
- Phase change with temperature at 10MHz: $\leq 0.1^\circ/10^\circ\text{C}$ to 60°C
- Phase noise: see Table
- Linearty: see Table

SSB Phase Noise

Harmonic Distortion Data

		Frequency		Levels	
		5MHz	+10dBm	+7dBm	
Input: +10dBm @ 5MHz		Output: _____			
Hz from the carrier	dBV/Hz	Output: _____			
1	-136	5MHz	+18dBm	+15dBm	
10	-146	10MHz	-81dBc	-79dBc	
100	-156	15MHz	-65dBc	-68dBc	
1000	-166	20MHz	-Signals below-		
10000	-174	25MHz	measurement floor		
25000	-174				

Testing Notes

At the lower signal levels, accidental common-mode ground noise, both coherent line harmonics and broadband noise, will probably be the biggest obstacle to a repeatable test setup. Also, slow line variations will disturb long sweep time measurements. In my own laboratory, I run all equipment involved in a particular test off one line-conditioning ferro-resonant transformer. Then,

in addition to signal grounds, I run chassis-to-chassis ground straps.

After a carrier has been phase-detected, the resultant information is amplitude noise, equivalent to the phase noise. The relationship between the two is the phase-detector sensitivity.[6,7] Almost any indicating device can be used after a low-noise preamplifier. Values indicated by various analyzers or even a single frequency (for example 1 Hz center frequency) operational amplifier filter [8] can be normalized to a 1 Hz bandwidth to provide interchangeability of numbers. There is a limitation in that filter bandwidth must be equal to or less than one tenth of the filter's center frequency.[9] Resultant calibration can be verified using the precision noise source described in NIST paper, "Accuracy Model for Phase Noise Measurements." [10] This and some other papers relevant to phase noise analysis are listed in the bibliography.

To observe the AM-to-PM conversion of an RF amplifier, amplitude modulate the RF signal at some low level (-80 dBc) with a high quality modulator, then measure the resultant phase noise side bands at the amplifier output. This can give real-time feedback on the effects of circuit changes.[6] (Figure 8)

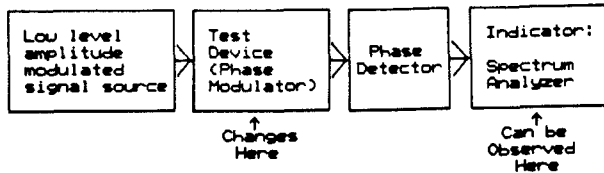

Figure 8

Figure 9 is a block diagram of the test setup used to evaluate the FET iso-amplifier. I used two iso-amplifiers to get the same conditions at both inputs of the phase detector. The resultant figure is the sum of the noise of the two amps. Phase noise coherent to the two amplifiers under test, such as phase noise induced by common power supply noise, will cancel in the phase detector. This has been known to give painfully misleading test results.

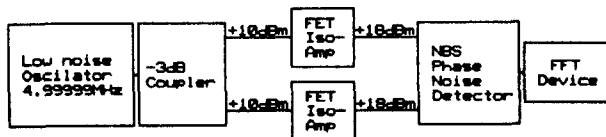

Figure 9

Figure 10 shows a block diagram of a common form of quadrature phase noise measurement system. Measuring original oscillator phase noise is somewhat complicated in that at least two identical oscillators that can be phase locked to each other are required.[6,10] A single oscillator and -3dB coupler will provide the two coherent signals for other tests. However, a second, non-critical oscillator will be required for calibration.[7,10]

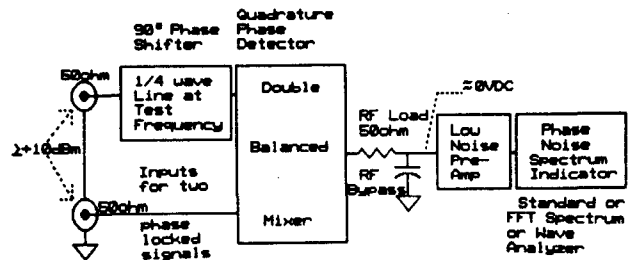

Figure 10

The amplitude noise test results reported for figures 2, 3, and 4, have a repeatability range of ± 1 to 2 dB. The phase noise figures quoted for the amplifier in figure 7 are ± 2 to 3 dB. More time with the same equipment will yield better accuracy.

Low-Amplitude-Noise Preamplifier

Figure 11 is a low-noise video preamplifier using standard parts which can be used in front of a standard or fast Fourier transform (FFT) spectrum analyzer to evaluate amplitude noise. It can also be used after a phase detector for the evaluation of phase noise.

OUTPUT NOISE
(with shorted input)

1Hz	-139dBV/Hz
10	-167
100	-171
1000	-170
10000	-170

All amplitude measurements in this paper used this pre amp. It is the limiting factor on some of them. An "M" by a figure means measurement limited.

All resistors
RNS5 1%
Metal film
Except 2.43K RNS0

.1uF XR7 monolithic

Polarized caps are Tantalum

X100

0.1Hz TO 400kHz

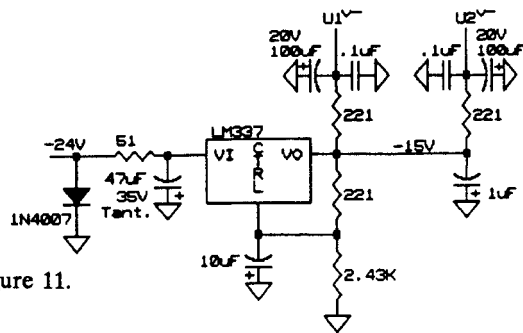
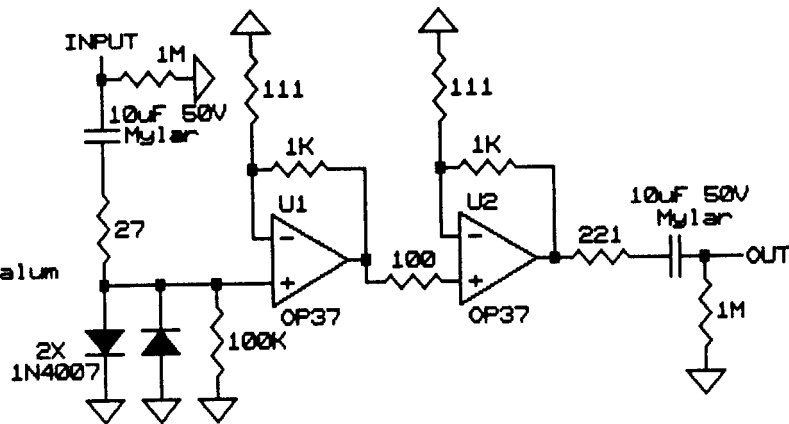
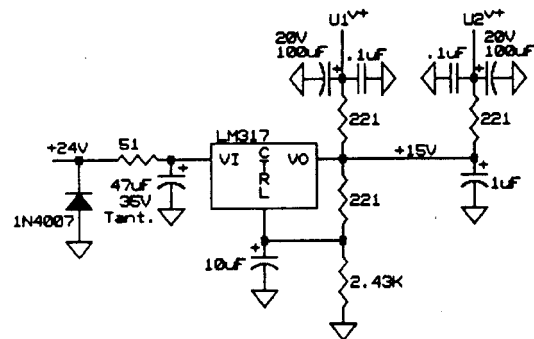

Figure 11.



CONCLUSION

When signal considerations extend 160dB or more below the carrier, calculated incremental design solutions can reach a point of diminishing returns. Attempting to optimize as many design parameters as possible right from the start will save a lot of time. Since amplitude noise is a major source of phase noise, a good beginning is to design the lowest amplitude noise circuit possible. Then make the reactive slopes of that circuit as flat as possible, and allow some form of emitter/source degeneration.

Use of phase-noise measurement equipment to obtain real-time empirical feedback, as regards the effects of design changes, is important in this area of design that is not yet fully understood. Using this paper and the reference publications, fabrication of a basic phase-noise measuring system capable of producing verifiable documentation can be accomplished in the average analog laboratory using existing equipment.

Initial design, component selection, layout, power supply requirements, and control of environment are each crucial in a high performance situation. Since phase noise is cumulative (multiplicative) for an entire system, system performance will be somewhat worse than the single worst gain block or device in a system. Achieving low phase-noise system performance requires careful attention to every individual function block in that system.

Acknowledgements

I thank Dr. Fred Walls for a great deal of productive discussion, and the other reviewers who guided this paper to its final form. The regulator of Figure 3 is the result of a conversation with Emmet Kyle, United States Navy.

References

- [1] "Amplifier Techniques," R331-351 and "Electrical Characteristics," 61-66, C. OP-AMP Cookbook 3rd ed., Walter G. Jung, (Howard W. Sams and Co. 1986).

- [2] "Emitter Coupled Differential Amplifier," pp. 111-120 and "Common Mode Rejection Defined," 115, GE Transister Manual, 7th ed. (General Electric Co. 1964).

- [3] "An Introduction to FETs," 7-11 and "FETs in Balanced Mixers (U431)," 55-64, Siliconix FET Data Book, (Siliconix Inc. 1986).

- [4] Jerry Sevick, "Transformer Analyses," and all of Transmission Line Transformers, (American Radio Relay League 1987).

- [5] Broadband Transformer Design Information, Iron-Powder and Ferrite Coil Forms, (Amidon Associates Inc. 1989).

- [6] F. L. Walls, C.M. Felton, A. J. D. Clements, "Accuracy Model for Phase Noise Measurements," Proc. of the 21st Annual Precision Time and Time Interval (PTTI) Meeting, Redondo Beach, CA, Nov. 28-30, 1989, pp. 295-310.

- [7] D. A. Howe, "Frequency Domain Stability Measurements: A Tutorial Introduction," NIST Tech Note 679, 1976.

- [8] Don Lancaster, "Multiple-Feedback Bandpass Circuit," Active Filter Cookbook, (Howard W. Sams and Co. 1988).

- [9] F. L. Walls and S. R. Stein, "Accurate Measurements of Spectral Density of Phase Noise in Devices," Proc. of the 31st Annual Frequency Control Symposium, 1977, pp. 335-343.

- [10] F. L. Walls, A. J. D. Clements, C. M. Felton, M. A. Lombardi, and M. D. Vanek, "Extending the Range and Accuracy of Phase Noise Measurements," Proc. of the 42nd Annual Frequency Control Symposium, Baltimore, MD, June 1-4, 1988, pp. 432-441.