

NBS Measurement Services:

Traceable Frequency Calibrations How to Use the NBS Frequency Measurement System in the Calibration Lab

NBS
Special
Publication
250-29

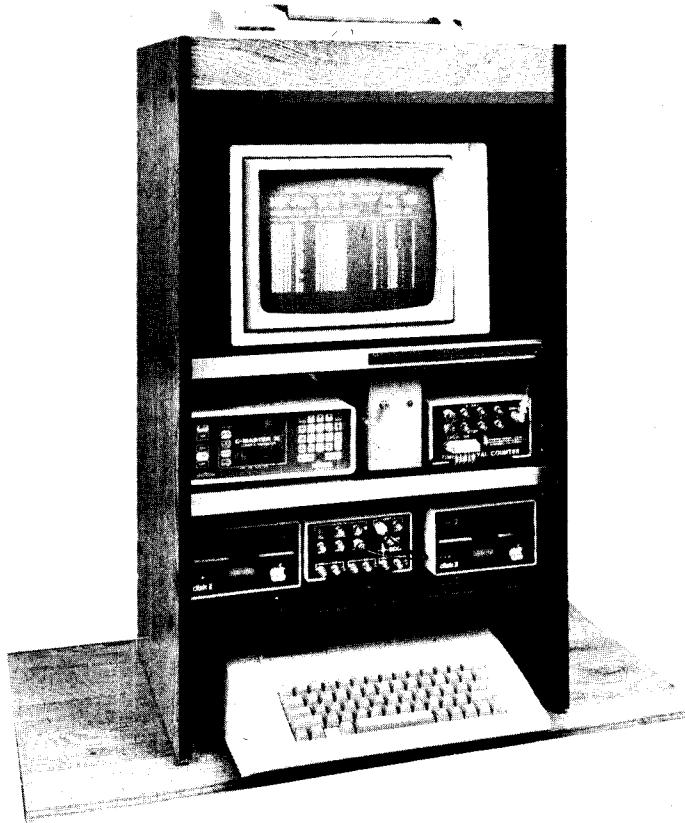

George Kamas and Michael A. Lombardi

U.S. Department of Commerce
National Bureau of Standards

Center for Basic Standards

The Center for Basic Standards develops and maintains the scientific competences and laboratory facilities necessary to preserve and continue to refine the base physical quantities upon which the Nation's measurement system is constructed. The Center is responsible for the standards of voltage, current, resistance and impedance, temperature, vacuum, leak rate, pressure, mass, length, time and frequency. The Center collaborates closely with the standardizing laboratories of other countries to ensure that measures used in international trade are fully compatible. The Center also performs research at the frontiers of physics in order to improve measurement capability and quantitative understanding of basic physical processes that underlie measurement science.

Electricity Division

Maintains and improves the national standards of electrical measurement; conducts experiments to realize the electrical units in terms of the mechanical units; develops stable electrical standards and improved methods for the dissemination of the units of electrical measurement; determines fundamental physical constants related to electrical units; develops instrumentation for precise electrical measurements directly referenced to the national standards; implements techniques for their use and puts them into practical applications; assists in applying scientific and technological development to measurement problems, especially in other areas of NBS research.

Temperature and Pressure Division

Maintains and improves the national standards of temperature and pressure; conducts research towards the development of new concepts for these standards; calibrates practical standards for the U.S. scientific and technical community in terms of the primary standards; develops methods and devices to assist user groups in the assessment and enhancement of the accuracy of their measurements of temperature and pressure; prepares and promulgates evaluations and descriptions of temperature and pressure measurement processes; coordinates these standards and measurement methods nationally and internationally; and determines the accuracy of the national standards of temperature and pressure with respect to fundamental thermodynamic relations.

Length and Mass Division

Develops and uses the competence necessary to implement a more accurate measurement system for length and mass; applies research, utilizing the most advanced technology available, to the improvement of our present standards and devises new standards and new methods for their transfer.

Time and Frequency Division

Maintains, develops and improves the national standards for the unit of time, the unit of frequency, and time scales based on these standards; carries out research in areas of importance to the further fundamental improvement of frequency standards and their applications focusing on microwave and laser devices, atomic and molecular resonances, and the measurement of fundamental physical phenomena and constants; adapts time and frequency standard devices and concepts to special scientific and technological demands; develops time and frequency measurement methods in the radiofrequency, microwave, infrared, and visible radiation regions; coordinates the NBS time scales with international time scales and the time scales maintained by the United States Naval Observatory; collaborates with national and international organizations in the development of improved methods for the measurement of time related quantities; operates time and frequency dissemination services, such as radio stations and broadcasts, for the purpose of traceability to the national standards of time and frequency.

Quantum Physics Division

Engages in research in atomic and molecular physics at the forefront of the field, and performs basic, highly accurate measurements and theoretical analyses that help establish a reliable foundation for scientific and technological measurement and data.

Quantum Metrology Division

Engages in forefront research in quantum metrology; contributes to new determinations of the fundamental physical constants, and the extension and refinement of the electromagnetic scale and devises, where possible, tests of basic symmetries and invariances.

NBS MEASUREMENT SERVICES: Traceable Frequency Calibrations How to Use the NBS Frequency Measurement System in the Calibration Lab

George Kamas and Michael A. Lombardi

Time and Frequency Division
Center for Basic Standards
National Measurement Laboratory
National Bureau of Standards
Boulder, CO 80303

January 1988



U.S. DEPARTMENT OF COMMERCE, C. William Verity, Secretary
NATIONAL BUREAU OF STANDARDS, Ernest Ambler, Director

Library of Congress Catalog Card Number: 87-619905

**National Bureau of Standards Special Publication 250-29
Natl. Bur. Stand. (U.S.), Spec. Publ. 250-29, 42 pages (Jan. 1988)
CODEN: XNBSAV**

**U.S. GOVERNMENT PRINTING OFFICE
WASHINGTON: 1988**

For sale by the Superintendent of Documents, U.S. Government Printing Office, Washington, DC 20402-9325

PREFACE

Calibrations and related measurement services of the National Bureau of Standards provide the means for makers and users of measuring tools to achieve levels of measurement accuracy that are necessary to attain quality, productivity and competitiveness. These requirements include the highest levels of accuracy that are possible on the basis of the most modern advances in science and technology as well as the levels of accuracy that are necessary in the routine production of goods and services. More than 300 different calibrations, measurement assurance services and special tests are available from NBS to support the activities of public and private organizations. These services enable users to link their measurements to the reference standards maintained by NBS and, thereby, to the measurement systems of other countries throughout the world. NBS Special Publication 250, NBS Calibration Services Users Guide, describes the calibrations and related services that are offered, provides essential information for placing orders for these services and identifies expert persons to be contacted for technical assistance.

NBS Special Publication 250 has recently been expanded by the addition of supplementary publications that provide detailed technical descriptions of specific NBS calibration services and, together with the NBS Calibration Services Users Guide, they constitute a topical series. Each technical supplement on a particular calibration service includes:

- o specifications for the service
- o design philosophy and theory
- o description of the NBS measurement system
- o NBS operational procedures
- o measurement uncertainty assessment
 - error budget
 - systematic error
 - random errors
- o NBS internal quality control procedures

The new publications will present more technical detail than the information that can be included in NBS Reports of Calibration. In general they will also provide more detail than past publications in the scientific and technical literature; such publications, when they exist, tend to focus upon a particular element of the topic and related elements may have been published in different places at different times. The new series will integrate the description of NBS calibration technologies in a form that is more readily accessible and more useful to the technical user.

The present publication, SP 250-29, NBS Measurement Services: Traceable Frequency Calibrations--How to Use the NBS Frequency Measurement System in the Calibration Lab, by Kamas and Lombardi, is one of approximately 20 documents in the new series published or in preparation by the Center for Basic Standards. It describes calibration technology and procedures utilized in connection with NBS Service Identification Numbers from 53110 to 53150 listed in the NBS Calibration Services Users Guide. Inquiries concerning the contents of these documents may be directed to the author or to one of the technical contact persons identified in the Users Guide (SP-250).

Suggestions for improving the effectiveness and usefulness of the new series would be very much appreciated at NBS. Likewise, suggestions concerning the need for new calibration services, special tests and measurement assurance programs are always welcome.

Joe Simmons, Acting Chief
Office of Physical Measurement Services

Helmut Hellwig, Acting Director
Center for Basic Standards

CONTENTS

	<u>Page</u>
Abstract.....	1
1. INTRODUCTION.....	2
1.1 What the New Service Does for the Calibration Laboratory.....	3
1.2 How the Frequency Measurement System Works.....	6
1.3 The Signals Connected to the Measurement System...	7
2. THE THEORY OF FREQUENCY MEASUREMENTS.....	9
2.1 Why Frequency Calibrations Are Unique.....	10
2.2 Traceability for Frequency Calibrations.....	11
2.3 Frequency Calibration Options Available to the Laboratory.....	13
2.4 Oscillator Specifications.....	13
2.5 What Does a Frequency Calibration Measure?.....	15
2.6 The Characteristics of Different Kinds of Oscillators.....	17
2.7 Setting Up the Frequency Lab.....	19
2.8 Record Keeping for Frequency Calibrations.....	21
3. THE NBS FREQUENCY MEASUREMENT SYSTEM.....	22
3.1 The Daily Operation of the NBS Frequency Measurement System.....	23
4. CONTROL OF THE NBS FREQUENCY MEASUREMENT SERVICE.....	27
4.1 Hardware Support.....	27
4.2 Training.....	27
4.3 Data Verification.....	28
4.4 Data Monitoring.....	29
4.5 Reporting Traceability.....	32
5. ASSESSMENT OF MEASUREMENT ERRORS USING THE NBS FREQUENCY MEASUREMENT SYSTEM.....	34
6. BIBLIOGRAPHY.....	36

TRACEABLE FREQUENCY CALIBRATIONS
HOW TO USE THE NBS FREQUENCY MEASUREMENT SYSTEM
IN THE CALIBRATION LAB

George Kamas and Michael A. Lombardi

Time and Frequency Division
National Bureau of Standards
Boulder, CO 80303

A practical approach to making traceable frequency calibrations in the calibration laboratory is discussed. This approach emphasizes obtaining traceable data, keeping appropriate records, and selecting an oscillator and a radio signal to use for calibrations. The NBS Frequency Measurement System is used to illustrate this approach, and to discuss the decisions to be made when setting up a calibration lab for frequency measurements. The theory of frequency measurement is also discussed, with emphasis on using time interval counters to obtain the relative frequency of an oscillator.

Key words: calibration; cesium oscillators; frequency measurement; Loran-C; quartz oscillators; relative frequency; rubidium oscillators; time interval counters; traceability; WWV; WWVB

OVERVIEW OF THIS PAPER:

In order that calibration laboratory personnel can get the gist of this paper quickly, the next few pages describe the NBS Frequency Measurement System rather briefly. Later in the paper, the system is discussed in more detail.

The reader is encouraged to scan these pages as an introduction to the later material. Or, if this is a second or third reading, these next few pages can serve as a quick review of the main features of the measurement system.

This paper uses scientific notation when discussing the accuracy of a frequency source. For example, if the relative frequency of a source is 1 part in 10 to the 11th, it will be written as $1.00E-11$.

1. INTRODUCTION

The National Bureau of Standards (NBS) began a new Frequency Measurement Service in 1984. The service made a state-of-the-art frequency measurement system available to the public. The system was developed by NBS using low cost, commercially available equipment.

The service provides NBS traceable frequency calibrations over a range from $1.00E-05$ to $1.00E-12$. The method used by the service involves common-view monitoring of low-frequency radio signals by the user and by NBS. NBS then provides information to correct the user's frequency data.

Subscribers to the NBS Frequency Measurement Service receive several benefits. NBS offers hands-on training and customer support. Measurements are made continuously (24 hours a day), and the equipment requires minimal operator attention. Another benefit to the frequency measurement community is the standardization of the process. Each user makes measurements using the same method, and NBS can share the benefits of many measurements (taken from every user site) with each subscriber.

1.1 What the New Service Does for the Calibration Laboratory

Every calibration laboratory needs a good oscillator to use as a frequency source. The oscillator must be accurate enough to meet the needs of the lab's customers and be periodically calibrated so that its accuracy is known.

Oscillators are sensitive to shipment, and to being turned on and off, so it is impractical to remove them from service and send them out for calibration. Instead, labs need to backup their oscillators with batteries, keep them running all the time, and continuously measure their performance. The more accuracy a lab requires, the more important this becomes. If the oscillator is a quartz or rubidium device, the lab needs to keep it adjusted so that it meets specifications. If the oscillator is a cesium device, it must be measured to ensure that its performance meets specifications.

To make frequency measurements in the laboratory, lab personnel need a measurement system. Subscribers to the new NBS service receive a complete frequency measurement system which they install using a detailed instruction manual. The subscriber needs to supply only two things: an oscillator and a telephone jack. The oscillator is the lab's primary frequency source. The phone jack lets the system be linked to NBS by modem. All other required items are supplied by NBS.

The assembled measurement system is about the size of a component stereo system and fits easily on a desktop or small table. It consists of a microcomputer with two disk drives and monitor, a frequency divider, a time interval counter, a Loran-C receiver, a printer, a telephone modem, and a time-of-day clock (see figure 1 on page 4).

The microcomputer controls the measurement system. Measurements are displayed on the monitor as they are being taken. The measurements are averaged, and the averaged data are stored on a floppy disk.

The frequency divider accepts input signals of 1, 5, or 10 MHz and produces lower frequency output signals. For example, it can divide a 10 MHz signal into a 1 Hz signal. In this way, signals of the same low frequency are obtained for use with the time interval counter.

The time interval counter has four channels (four start and four stop connectors). Therefore, it can measure the frequency performance of up to four separate oscillators. The counter makes measurements with 10 nanosecond resolution (see figure 2, page 5).



FIGURE 1 - PHOTOGRAPH OF THE NBS FREQUENCY MEASUREMENT SYSTEM

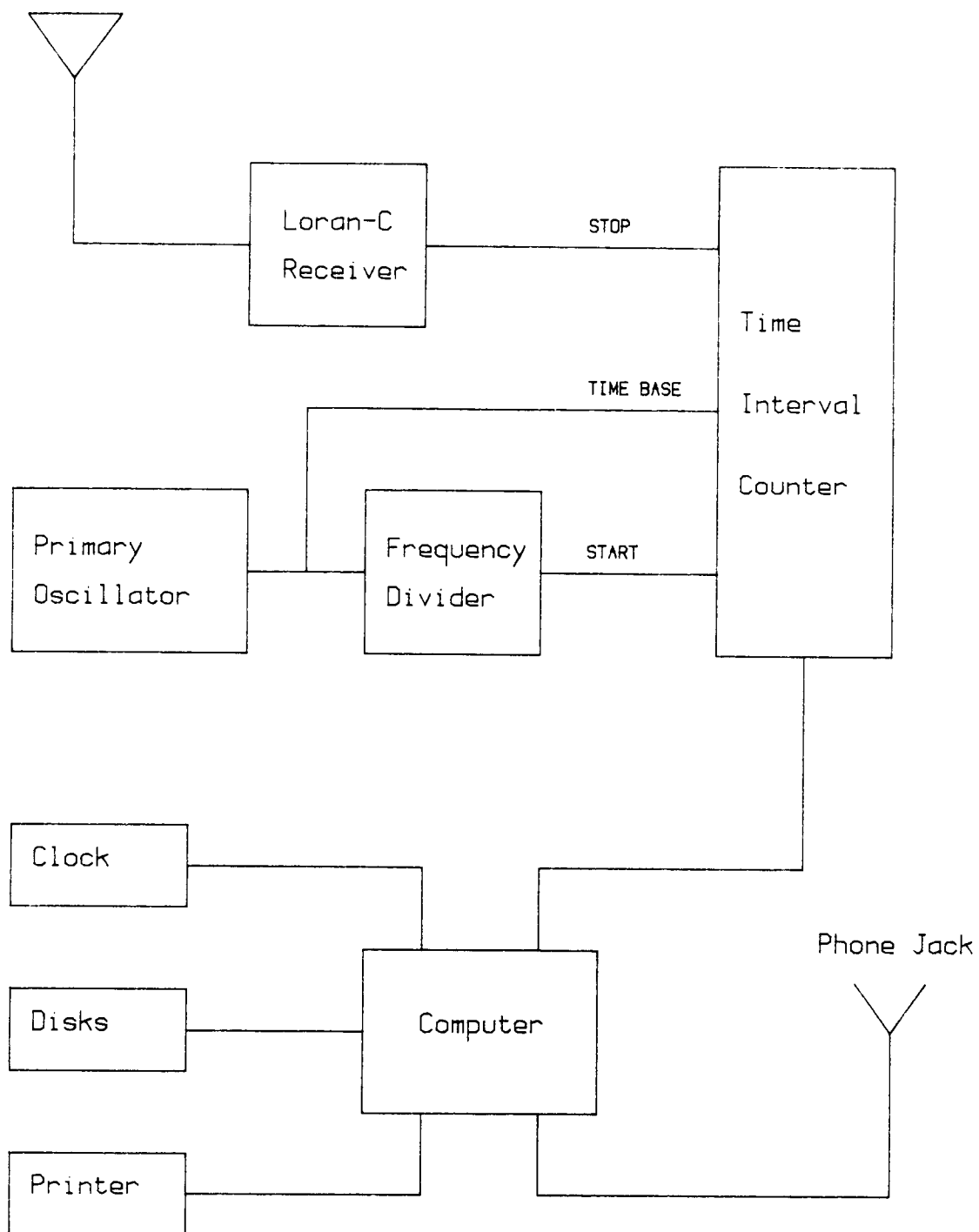

FIGURE 2 - DIAGRAM OF THE NBS FREQUENCY MEASUREMENT SYSTEM

The Loran-C receiver is fully automatic. When the user connects the antenna and power supply, the receiver begins tracking the signal from the nearest Loran-C transmitter. The antenna is an eight-foot whip, similar to a Citizen's Band (CB) radio antenna.

The printer produces daily calibration plots and is also used to send messages to users of the service.

The telephone modem is inside the microcomputer. It gives NBS access to the user's measurement system.

The time-of-day clock is also inside the microcomputer. It provides the timekeeping functions needed for the measurements.

1.2 How the Frequency Measurement System Works

The NBS Frequency Measurement System measures and records the performance of from one to four frequency sources. It runs 24 hours a day and restarts automatically after power outages.

The Frequency Measurement System is simple to start and runs itself once started. It is controlled entirely with software. The software automates the process of making frequency measurements and seldom requires operator attention. The software is "transparent," and users do not necessarily realize that they are using computer software, but instead feel that they are using a completely integrated system. From time to time, NBS refines the software to make it even more reliable, transparent, and integral to the system.

The system takes and averages time interval readings and stores (on floppy disk) the data and the time the data were taken. The time is obtained from the clock inside the microcomputer. Once each day, the system plots the data recorded in the previous 24 hours and prints a copy of the plot on the printer (figure 3, next page). These functions are performed automatically, without user interaction.

A calibration plot is made for each oscillator being measured. It shows the phase shift of the oscillator versus time of day and the estimated relative frequency of the oscillator. The relative frequency is printed above the plot. Relative frequency is calculated by fitting a linear least-squares curve to the data and taking the slope of the fitted line. The system can show relative frequency offsets as small as $1.00E-12$, or as large as $1.00E-05$. This allows the system to measure the full range of oscillators--from low-quality quartz oscillators to high-quality atomic oscillators.

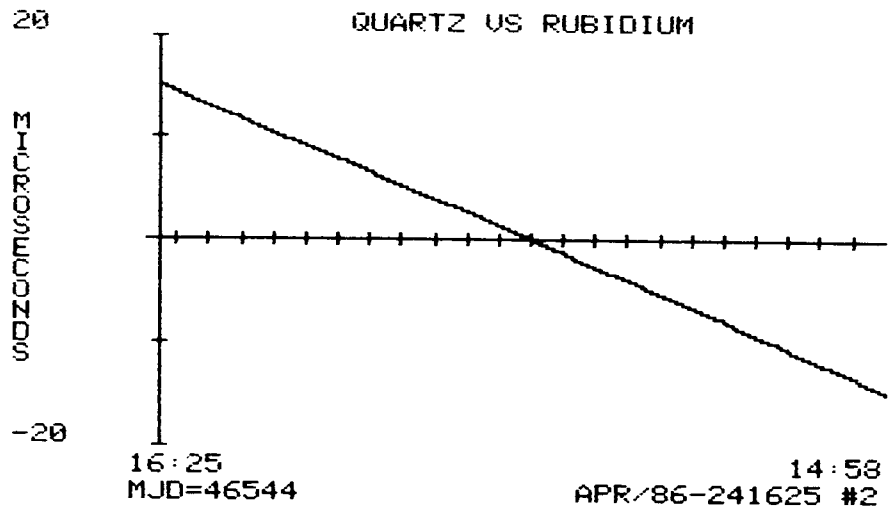

FIGURE 3 - A SAMPLE CALIBRATION PLOT

After the system plots, it starts taking readings for the next day. The process continues in this way: recording, plotting, recording, plotting, and so on. The only operator attention required is to occasionally change the data disk or to add paper to the printer.

1.3 The Signals Connected to the Measurement System

The frequency measurement service makes time interval measurements between two signals of the same frequency. One of these signals provides a reference frequency, and the other is the oscillator being measured. The time interval counter supplied with the frequency measurement service can measure the performance of four oscillators simultaneously. Channel 1 is dedicated to the calibration of the primary oscillator in the calibration laboratory. The performance of the primary oscillator is checked regularly by NBS for traceability.

Loran-C provides the reference frequency for the service. Each system comes with a radio that receives a signal from a Loran-C station. Loran-C is a radio navigation system maintained by the United States Coast Guard (Loran stands for LONG RANGE Navigation).

Loran-C signals make an excellent reference frequency for a number of reasons. They are extremely accurate--to about 1.00E-12 per day. This is good enough to check the performance of cesium oscillators and to calibrate rubidium or quartz oscillators. The continued accuracy of Loran-C is insured since the stations are controlled by cesium standards monitored by the U.S. Coast Guard and the U.S. Naval Observatory, in addition to NBS.

A second benefit is that Loran-C receivers are inexpensive and automatic. Finally, each Loran-C station has an effective range of over 1000 miles (1600 kilometers). Since numerous Loran-C transmitters are in operation, this means that the service can be used in all 50 states.

Loran-C is an NBS traceable frequency source, because its signals are received by both the user and NBS. NBS continuously monitors the Loran-C stations and compares the transmitted phase to the nation's frequency standard. Through this monitoring, NBS is able to report any phase shifts in the Loran-C signals and to measure the accuracy of the signals. Any abnormal phase shifts are reported to subscribers of the service. NBS also publishes the daily phase shifts of Loran-C, but these are generally too small to concern most users.

Channel 1 of the Measurement System is dedicated to the calibration of the primary oscillator in the laboratory. The primary oscillator is compared to the Loran-C reference frequency. Channels 2, 3, and 4 can be used to compare other oscillators to the primary oscillator (see figure 4, below).

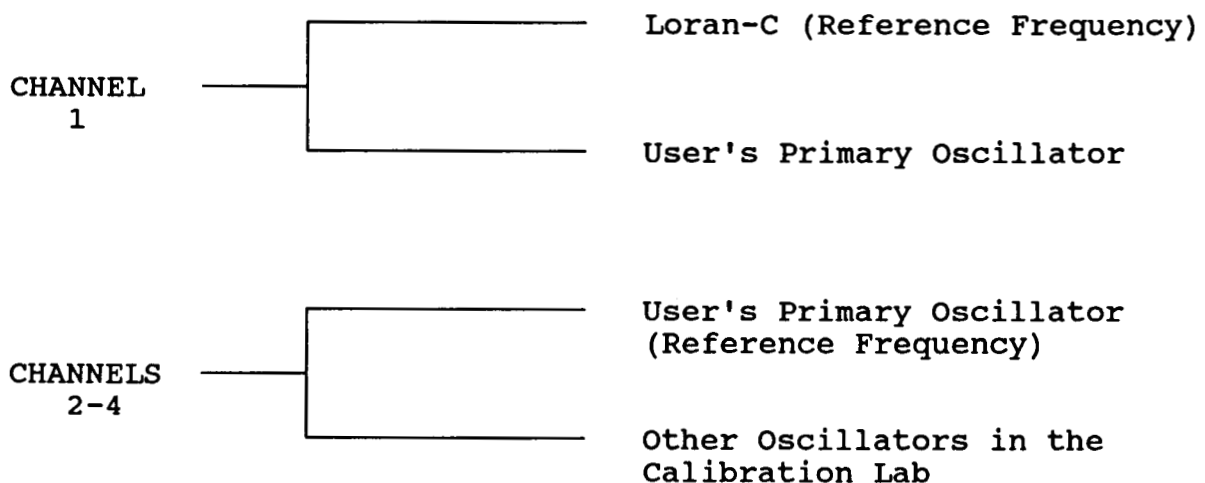

FIGURE 4 - CALIBRATION PROCEDURE USING THE NBS SYSTEM

2. THE THEORY OF FREQUENCY MEASUREMENTS

Frequency measurements are made by comparing signals from two frequency sources. This is true in music, for example, where the orchestra tunes its instruments from the oboe. In the same way, oscillators are measured, adjusted, and calibrated by comparing their output with the output from a higher quality frequency source. The higher quality frequency source can be a radio signal (WWV, WWVB, or Loran-C, for example) or another oscillator.

A simple and direct way to measure frequency is to use a frequency counter. The problem with this method is the time it takes to make measurements. The resolution of an ordinary counter is increased by increasing the gate time. For example, a 1 second count of a 1 MHz signal might give a resolution of 1 Hz. By counting for 10 seconds, the resolution improves to 0.1 Hz. This resolution was obtained by waiting longer. It would take many hours to reach the resolution of a precision oscillator ($1.00E-11$, for example). Even if the time were available, this method is not recommended because it allows only a few readings per day, and the chances for error become great. A system that must run continuously for hours to get one reading is very prone to errors due to power outages and other causes.

A better approach is to measure time interval instead of frequency. This method is faster. If two oscillators with 1 Hz outputs are compared using a time interval counter, a high resolution reading can be obtained every second. For example, the counter used by the NBS Frequency Measurement System has a 100 MHz time base. This means the measurement resolution obtained is $1 / 100,000,000$ of a second, or 10 nanoseconds. Therefore, changing from frequency to time interval measurements results in a dramatic increase in resolution.

Time interval measurements are in time units. The data taken measure the length of the period (in time units) between the signals being calibrated. For example, two signals are used to start and stop a time interval counter. The counter measures the period between the two signals. If their frequency is the same, the period will not change. If the frequencies differ, this period will change, although usually very slowly. It is exactly as if each signal source were a clock, and the data recorded tell whether one clock gained or lost time relative to the other clock.

The technique of measuring time interval to get frequency is common and is used by all high resolution systems. However, it requires taking two readings to get one data point. A single reading of the time interval between two clocks is not useful.

It is the second reading, subtracted from the first, that tells whether time is gained or lost. This gain or loss of time is a measure of the frequency difference between the two frequency sources.

2.1 Why Frequency Calibrations Are Unique

Laboratory frequency calibrations are unique for two reasons:

1. Oscillators cannot be shipped to NBS or another laboratory for calibration, because being turned on and off causes their frequency to change.
2. Since oscillators cannot be sent out for calibration, calibrations must be done on-site using radio signals. These radio signals permit even small laboratories to perform calibrations at an accuracy of $1.00E-12$.

Making calibrations on-site at high levels of accuracy requires following some carefully set guidelines. These guidelines are outlined in the following paragraphs.

Calibration labs must have a high-quality primary oscillator; either a quartz, rubidium, or cesium. The primary oscillator must meet the requirements for calibrating equipment that is now in the lab or expected soon. Quartz oscillators (based on prices at this writing) cost from \$500 to \$10,000. Rubidium oscillators cost from \$5000 to \$20,000, and cesium oscillators cost from \$30,000 to \$50,000.

The primary oscillator must have battery backup to prevent signal loss during power outages. It must run continuously and be calibrated daily using radio signals. Also, depending on location of the calibration laboratory, a distribution amplifier may be needed to prevent errors in the calibrations due to signal loss, line loading, or other causes.

Once the primary oscillator is selected, the calibrations must be made traceable. Most calibration labs provide equipment so that the primary oscillator can serve as the traceable laboratory source to calibrate other oscillators. The setup for making calibrations can be as simple as an oscilloscope, or as elaborate as a computer-controlled measurement system.

2.2 Traceability for Frequency Calibrations

Due to the conditions mentioned above (the need to use radio signals and the need to perform frequency calibrations on-site), traceability for frequency calibrations differs in some respects from other calibration activities.

The radio signal used must either be directly controlled by NBS, like WWV, WWVB, WWVH, GOES, and GPS, or monitored by NBS. Signals directly monitored by NBS include the Loran-C navigation signals. Signals indirectly monitored include the Navy VLF signals, the Omega navigation signals, and Canadian and European broadcast signals. All of these signals are useful because they are referenced to atomic oscillators. Since they are carefully controlled and monitored by other government agencies, and intercompared between national laboratories, traceability to NBS is assured. For example, users of the signals from radio station CHU in Canada can be assured that these signals can be traced to NBS, since the relationship between the Canadian and U.S. national standards is known. The accuracy level of the traceability is limited, however, by the number of steps in the traceability path. Users should investigate the limitations so that no confusion exists over what can or cannot be accomplished with a given signal.

Without trying to discuss all possible arrangements, traceability for frequency calibrations works like this: users of WWVB can obtain a monthly frequency bulletin from NBS that lists (after the fact) any known perturbations of the broadcast frequencies (figure 5, next page). Signal outages and special announcements are also listed. The U.S. Naval Observatory also mails or provides computer access to frequency data needed by defense contractors. Many other countries provide bulletins that announce corrections in their broadcasts. By using documents from NBS or elsewhere, the calibration lab can obtain enough data to establish a traceable path to NBS.

Obtaining traceability is not as difficult as it appears, since most users calibrate their oscillators at a level higher than needed. For example, if an oscillator maintains a relative frequency of $1.00E-08$ but calibrations are only required at a level of $1.00E-06$, small losses of accuracy in the traceability path will not affect the final results.

AUGUST 1987	MJD*	WWVB	LORAN-C (DANA)	LORAN-C (FALLON)
1	47008	5.68	62284.27	3942.22
2	47009	5.69	62284.33	3942.17
3	47010	5.69	62284.32	3942.20
4	47011	5.66	62284.31	3942.13
5	47012	5.67	(-)	(-)
6	47013	5.69	62284.27	3942.60
7	47014	5.69	62284.28	3942.48
8	47015	5.68	62284.25	3942.53
9	47016	5.67	62284.30	3942.43
10	47017	5.66	62284.31	3942.52
11	47018	5.68	62284.33	3942.46
12	47019	5.69	62284.36	3942.44
13	47020	5.68	62284.41	3942.52
14	47021	5.69	62284.40	3942.48
15	47022	5.69	62284.45	3942.39
16	47023	5.69	62284.43	3942.38
17	47024	5.69	62284.38	3942.45
18	47025	5.72	62284.45	3942.38
19	47026	5.68	62284.48	3942.41
20	47027	5.67	62284.45	3942.36
21	47028	5.66	62284.45	3942.37
22	47029	5.65	62284.30	3942.48
23	47030	5.65	62284.20	3942.58
24	47031	5.64	62284.30	3942.53
25	47032	5.66	62284.41	3942.39
26	47033	5.64	62284.36	3942.47
27	47034	5.67	62284.27	3942.47
28	47035	5.70	62284.39	3942.39
29	47036	5.72	62284.36	3942.38
30	47037	5.75	62284.39	3942.37
31	47038	5.77	62284.28	3942.44

* Modified Julian Date

FIGURE 5 - DATA FROM NBS TIME AND FREQUENCY BULLETIN

2.3 Frequency Calibration Options Available to the Laboratory

Users must decide which traceability path (including the radio signal and oscillator) meets their needs. Help is available from most manufacturers and also from the national laboratories that control the radio signals. NBS assists users in this area with publications, phone consultation, and training seminars.

The decision must be based on the level of calibration accuracy required by the laboratory. If the required accuracy is very high, or if it can be expected to increase in coming years, then consider only those radio signals which support that level of accuracy. For example, WWV can be used to calibrate an oscillator of modest performance, but a high-performance oscillator may require using signals from WWVB or Loran-C.

The choice of radio signal is also limited by the location of the laboratory, reception problems with certain radio signals, available equipment, and past experience. Another factor is whether the radio signal lends itself well to automation. It may be better to use a signal that is easy to automate, even if the initial cost of the equipment is high. If low-cost equipment is purchased, it may require a daily manual calibration procedure. In these instances, the labor costs will soon exceed the amount of money that was originally saved.

It is a good idea to talk with manufacturers and try the equipment before buying. There is also the option of talking with the NBS staff. They will often know from experience which services have worked best in a particular area.

2.4 Oscillator Specifications

It is important to know the specifications of the oscillator to be calibrated. It is especially important to know the specifications of the primary oscillator, since it is used to calibrate other oscillators that are brought into the laboratory.

The previous sections have discussed the technique to use when making frequency calibrations. To review, the lab should have a primary oscillator which is the best oscillator available to the laboratory. It should be battery-backed, kept running at all times, and be traceable to NBS. The primary oscillator can then be used to calibrate other oscillators. If carefully controlled and tended, the primary oscillator will provide excellent service and can be used even if the radio signal is temporarily lost.

With these criteria as a starting point, here is a review of some typical oscillator specifications:

ACCURACY: Accuracy is the result obtained from a calibration; it cannot be purchased. The manufacturer specifies the frequency of the oscillator after turn-on. The specification states what the accuracy of the oscillator will be after a specified warm-up period. This means that the factory has calibrated the oscillator, and the specification tells you what the unit will do after it has been turned off, shipped, and then turned back on.

STABILITY: At any given moment, an oscillator generates an output signal whose frequency depends on a number of factors: temperature, time since turn-on, line voltage, vibration and shock, and so on. Some time later its frequency will change, again due to a number of causes. The difference between its frequency at one moment in time and another moment is called stability. In other words, how stable is its frequency? This specification is usually given for a number of time periods: 1 second, 10 seconds, minutes, hours, or even days, months, or years. Stability is an important factor in oscillator cost. More stable oscillators cost more. Among the variety of quartz crystal oscillators available, the cost may range from a few hundred dollars for an oscillator with a stability of $1.00E-06$ per day to over \$5000 for a stability of $1.00E-11$ per day.

AGING: This specification is used for quartz oscillators. It tells the buyer what kind of change in frequency can be expected due to the passage of time and the resulting change of the quartz crystal inside the oscillator. Again, high-quality devices (with a slower aging rate) cost more. Rubidium oscillators also change their frequency over time, but for different reasons. Usually this change is small-- $1.00E-11$ per day is typical.

Another factor in the purchase of a primary oscillator is its adjustment range and resolution. Contact the vendor and ask for a demonstration. It does little good to pay a high price for an oscillator that cannot be adjusted with reasonable

effort. A simple screwdriver adjustment is much harder to set than a multi-turn dial. Keep in mind the need to make very small changes when adjusting an oscillator!

To summarize, each user wants as good an oscillator as the budget allows. The most important specification is stability, and it may be that only atomic oscillators can satisfy some applications. However, read the other sections of this paper before making a final decision. It is sometimes better to have two modest oscillators rather than one very expensive one, especially when dependability is important and repair costs are high.

2.5 What Does a Frequency Calibration Measure?

Frequency calibrations measure the relative frequency of the oscillator. The time interval over which measurements are performed is important. For the topic covered by this paper (laboratory calibrations of a primary oscillator), a time period of 1 day (24 hours) has been chosen. Shorter time intervals are a special case and are not addressed here.

From this starting point, two things need to be considered: the mathematics of calibrations, and the names and symbols to be used. In each case, this paper follows international practices of the time and frequency industry and the major calibration laboratories.

A measurement becomes a calibration if it compares the oscillator's long-term frequency to the national frequency standard, UTC(NBS). UTC(NBS) stands for Coordinated Universal Time at NBS. Traceability to NBS means that an oscillator was compared to UTC(NBS) over a traceable path (using WWVB, Loran-C, etc.).

The desired result of a calibration is to obtain the relative frequency of the oscillator. The international symbol for relative frequency is F . Relative frequency is defined by the following equation:

$$\text{Relative frequency} = F = \frac{[f(\text{actual}) - f(\text{nameplate})]}{f(\text{nameplate})}$$

The nameplate frequency (usually 1, 5 or 10 MHz) is what the frequency of the oscillator should be. If an oscillator operated at its nameplate value, it would be a perfect frequency source. In the real world, however, there is always some frequency error, or a difference between the actual frequency and the nameplate frequency. This frequency error is what a calibration tries to measure. In much of the literature, this is referred to as delta F (delta means a small difference).

The equation finds the size of the frequency error. Dividing delta F by the nameplate value normalizes the equation. This lets the operator ignore the actual oscillator frequency and concentrate on the frequency error.

For example, if a 1 000 000 Hz (1 MHz) oscillator has an actual output frequency of 1 000 001 Hz, it is in error by 1 Hz. The 1 Hz error represents one cycle out of a possible million, or 1.00E-06. In the equation, the numerator is 1 and the denominator is 1 000 000. This means that $F = 1.00E-06$. F is the relative frequency. In this example, then, the frequency error relative to the nameplate value is 1.00E-06. In other words, the oscillator frequency is in error by one part in a million.

The sign of F changes from + to - if the oscillator output is lower than the nameplate. This again follows international convention and is the practice followed by many manufacturers. F is a number and has no dimensions like hertz or percent. Being a numeric, it does not depend on the oscillator frequency. For example, if a 10 MHz oscillator had an actual frequency output of 10,000,010 Hz, it would also have an F of 1.00E-06. Now, if this 10 MHz oscillator was compared with the 1 MHz oscillator mentioned earlier, the relative frequency between them would be zero (as expected)! This notation is used so that oscillators can be compared, while ignoring their nameplate frequency.

Relative frequency, or F, is a way to talk about an oscillator's performance in a way that is easy to understand; the oscillator is either higher or lower in frequency than it is supposed to be. Measuring relative frequency requires dealing with very small quantities. This is because, when calibrating high-quality oscillators, the difference between the actual frequency and the nameplate frequency is very small.

To summarize, the result of a frequency calibration is to obtain the value of F for a primary oscillator for a time period of 1 day (24 hours). The primary oscillator then becomes a traceable frequency source.

2.6 The Characteristics of Different Kinds of Oscillators

Quartz, rubidium, and cesium oscillators are the three main types of oscillators used in calibration laboratories. They are discussed in this section.

Quartz Oscillators - Quartz oscillators vary in form, price, and stability. For example, every frequency counter has an internal quartz oscillator that it uses as a time base. The counter's measurements are made relative to its time base, so the time base should be periodically calibrated. More expensive time bases require calibration less often and usually give better measurements between calibrations.

The quartz oscillators used in frequency counters suffer from being turned off and on between use. Some counters provide a standby feature that allows the oscillator to stay on and warmed up even though the other circuits in the counter are off. Few counters, however, allow for battery backup of their time base oscillators, and battery backup is required if the time base is used as a primary oscillator. Therefore, if a quartz is chosen as the primary oscillator, it will probably be a free-standing unit. These units range in price from a few hundred to many thousands of dollars.

Both time-base and free-standing oscillators have adjustment knobs or screws that are turned to put the oscillator on the correct frequency. Quartz oscillators change their frequency due to the aging of the quartz crystal itself. Since aging is a continuous process, adjustments must be made on a regular schedule. Other factors (like room temperature and voltage) also affect the data. Needless to say, the laboratory manager needs to study the situation and try to prevent frequency changes due to outside causes.

After a quartz oscillator has been calibrated for a period of time, an adjustment schedule should be planned. Some operators like to make adjustments on Friday so the oscillator can settle down over the weekend. Since it is recommended that data be taken every day, by the following Monday several days of data can be studied to see how well the adjustment was made. In this way, the lab can keep a lower quality oscillator adjusted and not have to buy a more expensive unit. It is good practice to have two oscillators running all the time. The second oscillator serves as a backup, adds confidence to the calibration process, and makes it easier to troubleshoot the calibration system when errors occur.

Rubidium Oscillators - Rubidium oscillators overcome some disadvantages of quartz oscillators. A rubidium oscillator contains a quartz oscillator whose frequency is forced to follow certain characteristics of a rubidium gas cell. The result is a very stable frequency source that normally changes its frequency much more slowly than a quartz oscillator without rubidium control. Since rubidium oscillators are more stable, they give better results with fewer adjustments than quartz oscillators. The tradeoff is in the price. Rubidium oscillators cost more initially. However, the price of a rubidium oscillator should be compared to the price of the quartz oscillator, plus the labor costs involved in keeping the quartz oscillator adjusted.

Cesium Oscillators - By definition, cesium oscillators are a primary frequency source. This means that, when operated correctly and not broken, a cesium oscillator will be very close to its correct frequency without any calibration. However, it is extremely important to know that a cesium oscillator is operating correctly, especially at the limit of its performance capability. Since the expected level of performance is so high, checking the performance is a very important part of operating a cesium oscillator.

Review of oscillator characteristics:

QUARTZ	Performance is in the range of 1.00E-06 to 1.00E-11 per day. Requires more adjustment than rubidium or cesium, but its low cost allows the option of having more than one.
RUBIDIUM	Cost more than quartz oscillators, but need less adjustment and usually perform better. Frequency change should be around 1.00E-11 per day.
CESIUM	The primary frequency standard, a cesium can be operated without calibration if correct procedures are followed and if the device is not broken. However, a cesium must be calibrated if documented traceability is required. Cesiums are the most expensive type of oscillator to purchase and repair. The beam tube inside the oscillator must be replaced every 3 to 5 years, at a cost of \$10 000 or more.

Should oscillators be adjusted, or should they be allowed to run and their frequency error measured? In other words, if an oscillator's frequency error is known, should it be adjusted at all, or should an allowance for the error be made when it is used to calibrate other oscillators? The answer to this question depends on the needs of the laboratory. If the oscillator is used to feed an in-house distribution system, it might be better to adjust it. On the other hand, if its output is used only in the calibration lab and the error can be allowed for in future calibrations, adjustments can be made less often. Remember, each adjustment carries the risk of maladjustment. Also, some oscillators are difficult to adjust. Sometimes it becomes a trial and error process that may take several days to complete.

A good practice is to start calibrations without adjustment for a period of several weeks. Then, try an adjustment to see how well it goes. If the results are satisfactory, set up a tentative schedule; once a week, for example. Try that for a while and change the interval if necessary. If adjustments prove difficult, space them out further. In the worst case, if the adjustments fail to meet the needs of the laboratory, consider using a different oscillator.

2.7 Setting Up the Frequency Lab

Once the radio receiver and oscillator are selected, set up the laboratory for calibrations. Remember, the primary oscillator needs battery backup and should operate in a stable environment. The radio needs access to the roof for its antenna and may also need access to a ground connection. Several antenna types are currently offered. VLF and Loran-C receivers generally operate with short vertical whips, but HF services like WWV need long wires for good, noise-free reception. Mount the antenna in an area free from obstructions and interference.

Arrange the equipment in the lab so that signals are available for checking other oscillators. Distribution amplifiers can be used to isolate the primary oscillator from possible disturbing influences, like long cable runs and power transients. Remember, a system that makes measurements with high resolution needs to be carefully planned.

There are several types of frequency measurement systems which the calibration lab manager can use, instead of designing a new system. Manufacturers offer VLF, LF, and Loran-C receivers that make measurements and record the data on chart paper. This equipment usually uses the primary oscillator as a receiver input. The receiver then makes the comparison and draws the chart. Front panel indicators assist in operating the system.

Receiver options include different types of antennas, some distribution capability, and even a way to discipline the primary oscillator to make it agree in frequency with the radio signal.

The NBS Frequency Measurement System mentioned throughout this paper is another option. It has most of the components necessary to perform frequency calibrations in the lab. It includes a Loran-C receiver and a multiple input counter for doing four measurements at one time. Channel 1 is used for the primary oscillator (measured versus Loran-C), and three additional channels are provided to accommodate other oscillators under test. For example, a lab using quartz oscillators could use the first two channels for their primary quartz oscillator and the backup. Then two additional channels are available for other oscillators. The system includes a printer that makes a daily calibration plot of all four channels, and a computer and disk drives to store the data.

Frequency measurement systems should run 24 hours a day if possible. It is not a good idea to start and stop the oscillator due to its tendency to change frequency. This is mainly a problem with quartz oscillators; rubidium and cesium oscillators have a minimal restart effect. However, all oscillators benefit from running continuously. It may also take a considerable amount of time for an oscillator to stabilize (a quartz oscillator may take a full week).

Radio signals are affected by events along their path (like bad weather and electrical interference). Therefore, data from a radio signal must be averaged when compared to a primary oscillator (which may be accurate to better than $1.00E-11$ per day). This is why 24 hours has been chosen as the period for calibration labs to use. Comparisons between two oscillators can be made more quickly, because no radio path noise is involved. After using an oscilloscope to reset a counter time base for example, the time base can be used immediately. However, the time base is subject to the same recovery time as any quartz oscillator, and a change in frequency can be expected for the first few days.

It is one thing to reset the frequency dial on an oscillator and quite another to expect the frequency to remain at the set value. This is why HF radio signals (like WWV) limit the accuracy obtained. The initial setting can be very accurate (even with the noise present on HF), but an adjusted oscillator takes some time to settle. This is also a consideration with equipment that synchronizes or disciplines an oscillator to a radio signal (WWVB, for example). In some cases, the oscillator may follow a radio signal which has noise on it.

2.8 Record Keeping for Frequency Calibrations

Enough records should be kept to satisfy the needs of the laboratory. For example, users of the NBS Frequency Measurement System can keep the daily plots in a notebook for future reference and diagnostic purposes. They can also keep the data on computer disk, as well as the monthly traceability report sent by NBS.

Users of an integral radio-oscillator-recorder can keep the chart records provided to support claims of traceable calibrations. If the signal being received is listed in an NBS or USNO publication, those documents can also be made part of the calibration data file.

Users of WWV who employ an oscilloscope for comparison can simply keep a daily log of their results. Such a notebook provides adequate proof of calibration, especially at the expected level of accuracy ($1.00E-07$).

Laboratories that use a cesium standard without radio comparisons need to keep a notebook of front panel meter readings. They should also include a history of adjustments following the manufacturer's instructions.

Calibration labs that need strong evidence of traceability should draw up a system block diagram showing how signals are generated, distributed, and calibrated. When changes are made, they can be noted on copies of the diagram. This method also keeps the lab manager aware of changes and problem areas and provides the information needed for future purchases.

The rest of this paper explains, in detail, how the NBS Frequency Measurement System is used as part of the overall system in a calibration laboratory, and how users of the system obtain traceable frequency calibrations.

3. THE NBS FREQUENCY MEASUREMENT SYSTEM

This section reviews what has been previously explained by using the NBS Frequency Measurement System as an example.

The NBS Frequency Measurement System brings together the commercial hardware and software items needed to perform state-of-the-art frequency calibrations. By following the procedure, each user gains from having a standardized measurement approach. The NBS makes data comparisons using telephone modem links. That way, a user whose data is in question can benefit from another user's data via the NBS telephone data link. This is especially important where maximum performance is required. The system calibrates all kinds of oscillators and even permits calibrating four oscillators simultaneously.

The NBS Frequency Measurement System is controlled by a computer with two disk drives, a monitor, and a printer. A Loran-C radio receives a traceable signal from a Loran-C transmitter. That signal is compared with the primary oscillator in the calibration laboratory. Any oscillator can be used since the system can operate at either 1, 5, or 10 MHz. Oscillators can be calibrated at levels up to $1.00E-12$.

Since Loran-C radio signals are subjected to path noise (like all radio signals), the system averages its data. It records data for 24 hours (one day). At the end of the day, it automatically plots the data and restarts itself for the next days run.

The system restarts after a power outage and generally operates unattended. The equipment in the NBS Frequency Measurement System is always turned on. The frequency divider, the Loran receiver, and the clock card inside the computer are backed up by batteries. The operator only needs to check the available disk space and printer paper. Even those conditions are monitored, and alarms indicate if the disk is full or the printer is out of paper.

The system's battery-backed frequency divider makes it easy to compare oscillators since it divides input frequencies of 1, 5, or 10 MHz to a more convenient 1 Hz for comparison purposes. It also provides a number of additional output signals that are useful for oscilloscope comparisons or system diagnostics. The divider also synthesizes a low-frequency Loran signal (about 10 Hz) from the primary oscillator.

The system's time interval counter can measure up to four channels simultaneously. It has no knobs or controls, and therefore eliminates measurement errors due to knob settings. The counter's time base frequency is obtained from the primary

oscillator. The time base frequency can be either 1, 5, or 10 MHz, and a lamp indicates if a time base signal is present.

By design, at 1530 UTC the system stops taking data and makes a paper plot of each channel being used. The plot shows the number of microseconds that were gained or lost in the 24 hour interval of the measurement. The unit for the vertical axis is microseconds. The unit for the horizontal axis is time of day (hours).

By looking at the plot, the operator can quickly assess the oscillator's performance. The plot also shows the system's estimate of the oscillator's relative frequency. This estimate is nearly exact for quartz oscillators with uniform aging. It is less accurate for high-precision oscillators, since the system automatically enlarges the plot to show the radio path noise. Of course, when comparing two oscillators on channels 2, 3, or 4, the estimated relative frequency will again be nearly exact. The automatic plotting and relative frequency features make the lab technician's job easier, make the calibrations less confusing, and reduce the amount of operator attention needed.

3.1 The Daily Operation of the NBS Frequency Measurement System

Like any measurement program, frequency measurement requires the lab technician to monitor the operation of the equipment and to make sure that the daily plots or charts are in order. The manuals included with monitoring equipment usually explain which front panel lamps and meters are important for daily system checks. Once a lab technician becomes familiar with the items that need to be checked daily, the daily check should take only a few minutes.

The NBS Frequency Measurement System was designed to make daily operation easy. Operators can perform a daily check by looking at the video screen (figure 6, next page).

NBS FREQUENCY MEASUREMENT SYSTEM			
START DATE:	11/19/86	START TIME:	1538
DISK SPACE:	63.5%	TIME:	1604
RUBIDIUM VS LORAN 9940		34183.32	
QUARTZ VS RUBIDIUM		19125.61	
<hr/>			
READING	435 OUT OF 1000	DATA POINT	1
<hr/>			
34183.37	19125.61		
34183.47	19125.61		
34183.46	19125.62		
34183.38	19125.62		
34183.38	19125.63		
34183.48	19125.63		
34183.39	19125.63		
34183.39	19125.64		
34183.49	19125.64		
34183.49	19125.65		

FIGURE 6 - SCREEN DISPLAY FOR THE NBS SYSTEM

The readings from each channel are displayed in a separate column. There is one column for one channel, two columns for two channels, and so on.

The screen shows the time when the measurement run began. This is usually just a few minutes after the 1530 UTC plot time. If the system was stopped and restarted, or if the power was lost, the restart time is shown on the screen. In addition, the present time of day is also shown on the screen. If that time is wrong for any reason, the operator can quickly reset the time from the keyboard without stopping the system. The screen also shows the title given to each measurement channel. A typical title might be:

Rubidium vs Loran 9940

This title tells anyone reading the plot what the record means, and identifies the oscillator being measured. All four channels are shown, and the separate daily plots can be easily filed for reference.

The screen also shows the very first reading taken on a particular measurement run. A glance at the screen shows how many microseconds the oscillator has moved relative to its comparison source. Channel 1 compares the primary oscillator to Loran-C. The other channels compare other oscillators to the primary oscillator.

The most important part of the daily check is to look at the phase plots printed by the system (figure 7, next page). The plots show the operator if the oscillator is high or low in frequency and estimate the oscillator's relative frequency. The operator can also tell if there were any losses of the signals being measured; for example, if the Loran-C receiver tracked properly for the last 24 hours. The operator will soon get a feel for how well each oscillator is expected to perform and will quickly be able to notice if an oscillator is broken.

All time of day noted on the NBS Frequency Measurement System is Coordinated Universal Time (UTC). Using UTC eliminates confusion caused by time changes and time zones. The date is shown both as calendar date (10/01/87, for example) and as a Modified Julian Date (MJD). This also helps sort out data and avoids confusion.

The operator must keep in mind that the quantity being measured is a very small number obtained by averaging. This means that even a small error at any time during the daily measurement run will affect the data. For this reason the equipment should be left on, sudden temperature changes should be avoided, and electrical interference (from cleaning equipment, power devices, generators, etc.) should be minimized.

NATIONAL BUREAU OF STANDARDS FREQUENCY CALIBRATION PLOT
RELATIVE FREQUENCY = $-2.66E-09$ 2000/26

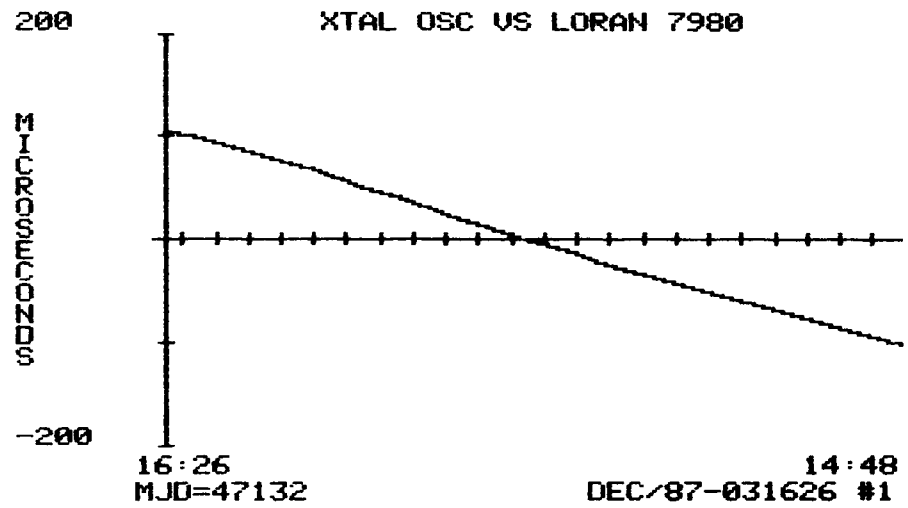

NATIONAL BUREAU OF STANDARDS FREQUENCY CALIBRATION PLOT
RELATIVE FREQUENCY = $-3.39E-09$ 2000/26

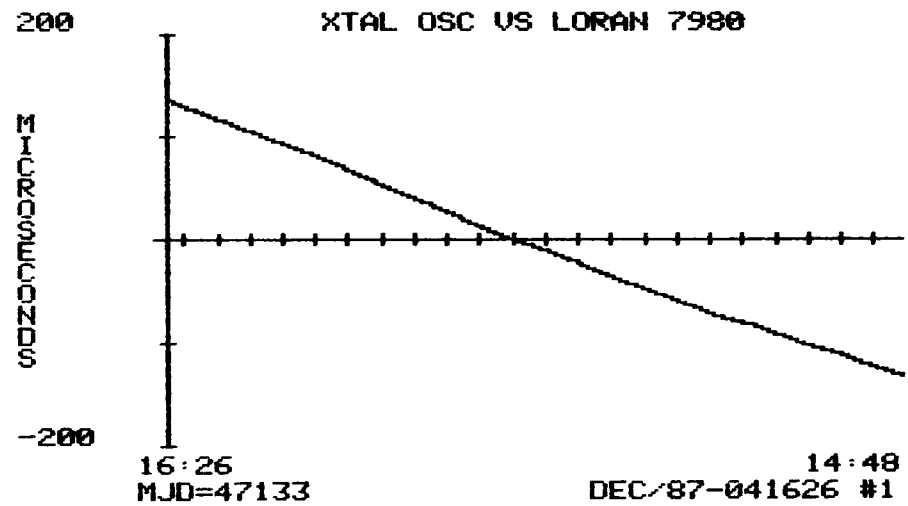

FIGURE 7 - DAILY CALIBRATION PLOTS

4. CONTROL OF THE NBS FREQUENCY MEASUREMENT SERVICE

An important part of the NBS Frequency Measurement Service is NBS support. This support is broken down into five categories: hardware support, training, data verification, data monitoring, and reporting traceability. Each category is discussed below.

4.1 Hardware Support

The Frequency Measurement System was designed using low-cost, reliable hardware. Low-cost hardware made the service economically feasible. Reliable hardware made the service possible. Each measurement system is intended to run 24 hours a day.

Most hardware failures occur soon after the hardware is installed. To eliminate this problem, each measurement system is burned-in and tested by NBS for a period of several weeks prior to shipment.

When parts fail in the field, every effort is made to minimize system downtime. NBS can usually determine which part failed by using the telephone modem. A replacement part (that was burned-in and tested) is then shipped to the user within 24 hours.

4.2 Training

As part of the initial service fee, NBS offers a training seminar to each measurement service subscriber. These seminars are held at NBS laboratories in Boulder, Colorado. They are limited to small groups and provide actual hands-on training with the measurement system. They also provide the user with a general background in frequency calibrations.

The training does not end when the user leaves Boulder. NBS provides telephone support for the service, and users may call any time during normal working hours. NBS is always happy to help users apply the service to specific applications they have in their own organizations.

4.3 Data Verification

As part of the service agreement, NBS looks at each user's data with the telephone modem. The system records phase and frequency data. The two types are explained below:

Phase Data - The phase data show the change in phase of the frequency being measured in comparison to the reference frequency. These data are plotted every morning, and a copy of the plot is printed. The Y-axis shows the change in phase (measured in microseconds), and the X-axis shows the time of day. The X and Y values are stored on disk before they are plotted and remain on disk after they are plotted.

Phase data are recorded on from one to four channels, and from one to four phase plots are printed each day. NBS can transfer any or all of the recorded phase data to the Boulder laboratories and reproduce the user's phase plots. However, phase data are generally transferred only if something unusual is spotted in the frequency data.

Frequency Data - Frequency data are recorded for channel 1 only. The data show the frequency offset of the user's primary oscillator relative to the Loran-C reference frequency. The relative frequency is printed on the phase plots for all channels but is recorded on disk for channel 1 only.

The file containing the frequency values is transferred to NBS by modem. NBS knows at a glance if the values are valid, because it has the frequency history of each user's primary oscillator. For example, NBS may know that a particular oscillator typically stays within $1.00E-10$ relative to Loran-C. The frequency file lists the following values:

Day 1	1.03E-10
Day 2	1.05E-10
Day 3	1.08E-10
Day 4	1.11E-10
Day 5	1.16E-10
Day 6	8.73E-08
Day 7	1.24E-10

The values for days 1-5 appear to be typical (about $1.00E-10$), based on the known past performance. The slight variations are normal and due to the aging rate of the quartz crystal. However, the value for day 6 is markedly different from the other values. It is obvious that a phase shift occurred on day 6. This shift

could have been caused by either one of the signals being compared (the primary oscillator or Loran-C), or perhaps by a system malfunction. To find the cause of the phase shift, NBS transfers the phase data for day 6 and reproduces the phase plot.

Once the cause of the phase shift is found, NBS does one of the following things:

- a. If a system part has failed, NBS replaces it.
- b. If the user's oscillator failed, NBS notifies the user.
- c. If a Loran-C phase shift occurred, NBS reports the phase shift to the user.

In the above example, items a and b above are unlikely causes of the phase shift occurring on day 6. The reason they are unlikely is that the system "recovered" and produced valid data for day 7. This does not usually happen when parts fail. Therefore, the most likely cause of the phase shift is Loran-C. NBS continuously monitors Loran-C and is aware of Loran-C phase shifts the day they occur. This is the topic of the next section.

4.4 Data Monitoring

NBS monitors the Loran-C stations received by subscribers of the service. This monitoring is done with the same equipment used by the subscribers. The stations monitored are listed below:

GRR*	Location
7980	Malone, Florida
8970	Dana, Indiana
9940	Fallon, Nevada
9960	Seneca, New York

* Group Repetition Rate

Since NBS monitors all of these stations, each user has a reference frequency in common-view to themselves and to NBS.

As mentioned earlier, users of the service make phase comparisons between their primary oscillator and Loran-C. Loran-C is the reference frequency, and the user's primary oscillator is the frequency being measured. NBS does the opposite; it measures the frequency of Loran-C by comparing it to the national frequency standard (figure 8, below). The national frequency standard is the reference frequency, and Loran-C is the frequency being measured. These comparisons let NBS know the relative frequency of Loran-C. Therefore, NBS knows if a phase shift in the user's data was caused by Loran-C.

The real strength of NBS monitoring lies in the amount of data that NBS looks at. NBS keeps at least two receivers (one backup) locked to each Loran-C station at all times. In addition, NBS looks at data from users in the field. Most users are closer to the station that they are monitoring than NBS is, and their data are often smoother than NBS data. Many of them use atomic oscillators and monitor Loran-C 24 hours a day, 365 days a year. This makes the NBS Frequency Measurement System the largest network of Loran-C monitoring in the United States.

The National Bureau of Standards Frequency Measurement Service

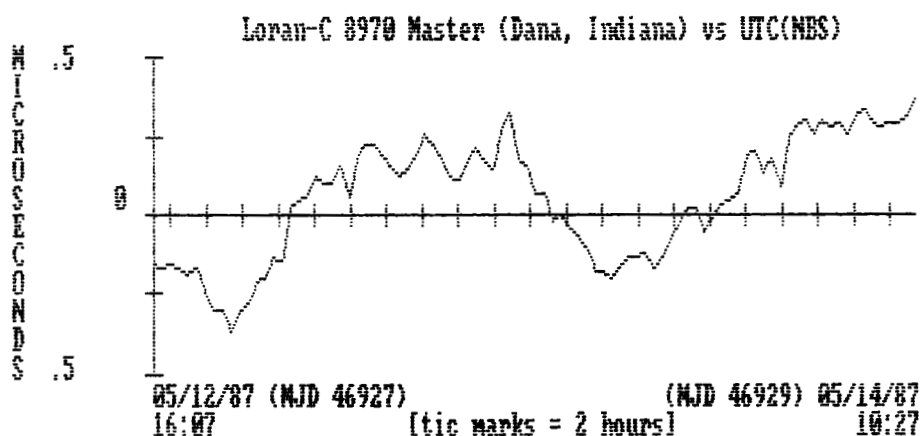
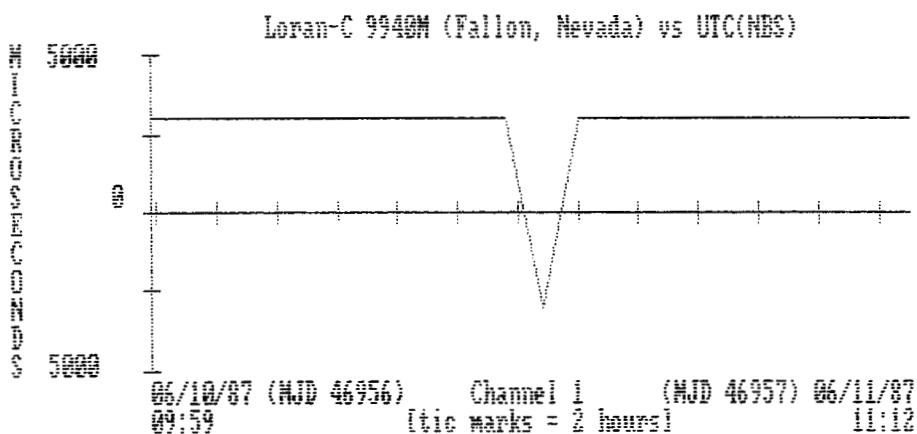

FIGURE 8 - LORAN-C DATA COMPARED TO UTC(NBS)

For example, if NBS data reveal a phase shift in a Loran-C signal (figure 9, below), it can be proved or disproved if this phase shift was "real" by looking at data from other users of the service.

The National Bureau of Standards Frequency Measurement Service



The frequency offset of the oscillator is: $-2.57E-10$ Data Points 21

FIGURE 9 - A LORAN-C PHASE SHIFT

If the phase shift occurred on the signals from Fallon, Nevada, NBS could look at the data from seven users (at this writing) who compare the Fallon, Nevada, signals to cesium oscillators. The location of these users and their distance and direction from the Loran-C transmitter are listed below:

Location	Distance (miles)	Direction
Albuquerque, NM	736	East
Los Alamos, NM	728	East
San Diego, CA	478	South
Pomona, CA	383	South
Seal Beach, CA	402	South
Alameda, CA	222	West
Keyport, WA	590	North

As the table illustrates, NBS is effectively tracking the frequency performance of Fallon from all directions at distances well within the range of Loran-C broadcasts. NBS monitors other Loran-C stations equally as well.

4.5 Reporting Traceability

Each user of the service receives a monthly frequency measurement report showing the frequency performance of their primary oscillator for the previous month (figure 10, next page). This report certifies that the user's measurements are traceable.

The report also lists any Loran-C phase shifts that occurred during the month, and any periods when the user's system was not running.

The National Bureau of Standards Frequency Measurement Report

The data below are shown as received at:

ABC CALIBRATIONS
ANYTOWN, USA
USER: JOHN Q. PUBLIC

The plot shows the frequency performance of your primary oscillator relative to Loran-C.
The data were taken from 09/01/1987 to 09/30/1987.

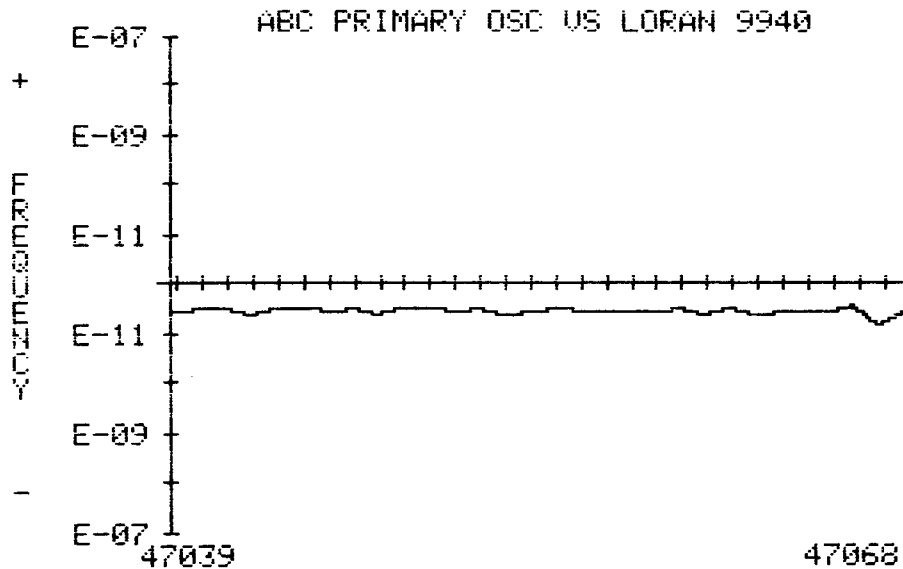

LORAN-C PHASE SHIFTS:

DAYS WHEN DATA WERE NOT PLOTTED:

COMMENTS:

FIGURE 10 - TRACEABILITY REPORT SENT TO USERS OF THE SERVICE

5. ASSESSMENT OF MEASUREMENT ERRORS USING THE NBS FREQUENCY MEASUREMENT SYSTEM

Based on empirical data from the NBS Time and Frequency Division and by others over a period exceeding two decades, the accuracy of Loran-C (as controlled by the Coast Guard and monitored by NBS and the United States Naval Observatory), is $1.00E-12$ per day. Therefore, the NBS Frequency Measurement Service should meet calibration requirements to this level. Possible sources of measurement errors are discussed below.

Measurement Errors of the Counter - All counter measurements are made in the time interval mode. The user's primary oscillator (often a Cesium or Rubidium) serves as a reference. Since readings are taken at intervals of about 1 second maximum and successive readings are differenced, errors caused by an inaccurate time base oscillator are minor. All equipment is tested prior to shipment. After shipment, further routine tests are made by having the user perform a self-check of the counter by using the same source for both the START and STOP inputs to the counter. Typical results for these tests are $1.00E-14$ per day. These errors are not significant.

Errors Due to Loran-C Variations - NBS can verify when propagation errors occur by checking its own data, data from user's systems, and data from other major laboratories (principally the U.S. Naval Observatory). Data obtained by NBS for several decades and by other major standard laboratories gives the error due to propagation as $1.00E-12$ for averaging times of several hours. All NBS Frequency Measurement Calibrations are operated for 24 hours to minimize the contribution of propagation errors. All of the United States Loran-C chains are monitored at Boulder by NBS.

Errors Due to Coast Guard Mandated Shifts of Loran-C Phase - From time to time (a few times a year), the U.S. Coast Guard shifts the phase of the Loran-C transmissions. This is usually done to cause the frequency (as broadcast) to track the average frequency of the U.S. Naval Observatory's oscillators. This frequency, in turn, is reported to the international control agencies.

NBS receives notice of changes in the broadcast phase of Loran-C and passes them on to users. In rare cases where the phase is inadvertently changed, NBS monitoring will detect and verify the change, and report it to the users.

To summarize, counter errors are not significant, and propagation errors are minimized by averaging. The phase control exercised by the Coast Guard is carefully monitored by NBS and other major laboratories. Therefore, there should be no significant measurement errors when using the NBS Frequency Measurement System.

6. BIBLIOGRAPHY

Booker, S. R.; Jones, M. C. The NBS Frequency Measurement System From a User's Viewpoint. NCSL 1984 Workshop and Symposium; 1984 October; Gaithersburg, MD. 1-11.

Howe, S. L., ed. NBS Time and Frequency Dissemination Services. Nat. Bur. Stand. (U.S.) Spec. Publ. 432; 1979 September. 20 p.

Jespersen, J.; Fitz-Randolph, J. From Sundials to Atomic Clocks: Understanding Time and Frequency. Nat. Bur. Stand. (U.S.) Monogr. 155; 1977 December. 177 p.

Kamas, G.; Howe, S. L., eds. Time and Frequency User's Manual. Nat. Bur. Stand. (U.S.) Spec. Publ. 559; 1979 November. 256 p.

Kamas, G.; Lombardi, M. A. A New System For Measuring Frequency. NCSL 1985 Workshop and Symposium; 1985 July; Boulder, CO. 224-231.

United States Coast Guard. Loran-C User Handbook. Dep. of Tran. (U.S.) COMDTINST M16562.3; 1980 May. 82 p.

U.S. DEPT. OF COMM. BIBLIOGRAPHIC DATA SHEET <i>(See instructions)</i>	1. PUBLICATION OR REPORT NO. NBS/SP-250/29	2. Performing Organ. Report No.	3. Publication Date January 1988
4. TITLE AND SUBTITLE NBS Measurement Services: TRACEABLE FREQUENCY CALIBRATIONS HOW TO USE THE NBS FREQUENCY MEASUREMENT SYSTEM IN THE CALIBRATION LAB			
5. AUTHOR(S) George Kamas and Michael A. Lombardi			
6. PERFORMING ORGANIZATION <i>(If joint or other than NBS, see instructions)</i> NATIONAL BUREAU OF STANDARDS DEPARTMENT OF COMMERCE WASHINGTON, D.C. 20234		7. Contract/Grant No.	8. Type of Report & Period Covered Final
9. SPONSORING ORGANIZATION NAME AND COMPLETE ADDRESS <i>(Street, City, State, ZIP)</i> Same as item 6.			
10. SUPPLEMENTARY NOTES Library of Congress Catalog Card Number 87-619905 <input type="checkbox"/> Document describes a computer program; SF-185, FIPS Software Summary, is attached.			
11. ABSTRACT <i>(A 200-word or less factual summary of most significant information. If document includes a significant bibliography or literature survey, mention it here)</i> A practical approach to making traceable frequency calibrations in the calibration laboratory is discussed. This approach emphasizes obtaining traceable data, keeping appropriate records, and selecting an oscillator and a radio signal to use for calibrations. The NBS Frequency Measurement System is used to illustrate this approach, and to discuss the decisions to be made when setting up a calibration lab for frequency measurements. The theory of frequency measurement is also discussed, with emphasis on using time interval counters to obtain the relative frequency of an oscillator.			
12. KEY WORDS <i>(Six to twelve entries; alphabetical order; capitalize only proper names; and separate key words by semicolons)</i> calibration; cesium oscillators; frequency measurement; Loran-C; quartz oscillators; relative frequency; rubidium oscillators; time interval counters; traceability; WWV; WWVB			
13. AVAILABILITY <input checked="" type="checkbox"/> Unlimited <input type="checkbox"/> For Official Distribution. Do Not Release to NTIS <input checked="" type="checkbox"/> Order From Superintendent of Documents, U.S. Government Printing Office, Washington, D.C. 20402. <input type="checkbox"/> Order From National Technical Information Service (NTIS), Springfield, VA. 22161		14. NO. OF PRINTED PAGES 42 15. Price	

THE SP 250 SERIES ON NBS MEASUREMENT SERVICES*

<p>SP 250-1 Spectral Radiance Calibrations 003-003-02792 \$3.50</p> <p>SP 250-2 Far Ultraviolet Detector Standards 003-003-02810-0 \$4.25</p> <p>SP 250-3 Radiometric Standards in the Vacuum Ultraviolet 003-003-02806-1 \$6.50</p> <p>SP 250-4 Fricke Dosimetry in High-Energy Electron Beams 003-003-02816-9 \$2.75</p> <p>SP 250-5 Alpha-Particle Calibrations</p> <p>SP 250-6 Regular Spectral Transmittance 003-003-02805-3 \$3.25</p> <p>SP 250-7 Radiance Temperature Calibrations 003-003-02827-4 \$2.25</p> <p>SP 250-8 Spectral Reflectance 003-003-02812-6 \$7.00</p> <p>SP 250-9 Calibration of Beta-Particle-Emitting Ophthalmic Applicators 003-003-02817-7 \$2.00</p> <p>SP 250-10 Radioactivity Calibrations with the "4π" Gamma Ionization Chamber, and Other Radioactivity Calibration Capabilities 003-003-02824-0 \$2.25</p> <p>SP 250-11 Dosimetry for High-Dose Applications</p> <p>SP 250-12 Neutron Personnel Dosimetry 003-003-02811-8 \$2.50</p> <p>SP 250-13 Activation Foil Irradiation with Californium Fission Sources</p> <p>SP 250-14 Activation Foil Irradiation by Reactor Cavity Fission Sources</p>	<p>SP 250-15 Photometric Calibrations</p> <p>SP 250-16 Calibration of X-Ray and Gamma-Ray Measuring Instruments</p> <p>SP 250-17 The NBS Photodetector Spectral Response Calibration Transfer Program</p> <p>SP 250-18 Neutron Source Strength Calibrations</p> <p>SP 250-19 Calibration of Gamma-Ray-Emitting Brachytherapy Sources</p> <p>SP 250-20 Spectral Irradiance Calibrations 003-003-02829-1 \$5.50</p> <p>SP 250-21 Calibration of Beta-Particle Radiation Instrumentation</p> <p>SP 250-22 Platinum Resistance Thermometer Calibrations 003-003-02831-2 \$17.00</p> <p>SP 250-23 Liquid-in-Glass Thermometer Calibration Service</p> <p>SP 250-24 Standard Cell Calibrations 003-003-02825-8 \$2.75</p> <p>SP 250-25 Calibration Service for Inductive Voltage Dividers</p> <p>SP 250-26 Phase Angle Calibrations</p> <p>SP 250-27 AC-DC Difference Calibrations</p> <p>SP 250-28 Solid-State DC Voltage Standard Calibrations</p> <p>SP 250-29 Traceable Frequency Calibrations</p> <p>SP 250-30 GOES Satellite Time Code Dissemination: Description and Operation</p>
---	---

* Those entries containing a stock number (003-003---) and price can be purchased from the Superintendent of Documents, U.S. Government Printing Office, Washington, DC 20402. GPO will accept checks, money orders, VISA, and Mastercharge. For more information, or to place an order, call (202) 783-3238. Be sure to use the stock number in all orders. Titles without stock numbers are in preparation.

U.S. Department of Commerce
National Bureau of Standards
Gaithersburg, MD 20899

Official Business
Penalty for Private Use \$300