

EPR Sample Orientation Servo

D. J. SUKLE

University of Colorado, Boulder, Colorado 80302

AND

J. S. WELLS

National Bureau of Standards, Boulder, Colorado 80302

(Received 16 November 1967)

IN many electron paramagnetic resonance (EPR) experiments, it is frequently desirable to change the orientation of the sample with respect to the cavity without removing the cavity from the spectrometer. This is the case when one is empirically searching for the orientation of the principal axis of the crystalline field

interaction with respect to the crystal morphology. Another example occurs when one uses a combination of the symmetry properties of the crystal and its EPR spectrum as tools for aligning the sample.¹ This note describes a simple device which we have found convenient for this purpose.

A sketch of this device is shown in Fig. 1. The epoxy and silver cavity which houses the device has been previously described.² The sample orienter is essentially a mechanical servo comprised of two ball and socket joints which are constrained by four lengths of mercerized cotton thread to move together, as shown. Obviously, three lengths of thread could also be used. The pedestal and crystal mounting platform within the cavity are made of Teflon to avoid excessive dielectric loading of the cavity. The brass stud outside the cavity is screwthreaded to permit adjustment of the tension in the cotton thread. A simple knot holds the thread to the Teflon platform, and a fiber washer and brass nut clamp the thread to the lower end. The threads are attached in planes which pass through the center of each ball joint. The thread lengths are adjusted such that these two planes are parallel. This is accomplished by loosening the brass nut sufficiently that the threads will slip through the clamp when pulled, but otherwise remain stationary. After the lengths are equalized, the clamp is tightened, and the tension is adjusted by the brass stud. If one attaches the threads to points on circles of equal radii for both upper and lower platforms, a normal to the Teflon platform will be parallel to the brass manipulator outside the cavity.

The particular device described has several desirable attributes. The principal ones are its simplicity of construction and ease of operation. It loads the sample cavity very little, and not only shifts the resonant frequency of the cavity much less than an earlier version¹ utilizing a single ball and socket, but also permits rotation through a much larger polar angle. By proper design the sample platform normal can be oriented to any angle within a cone of 60°. A small amount of tacky grease on both ball joints prevents the manipulator from falling back to a vertical orientation after an adjustment. The most difficult part of the construction (for the uninitiated) is making the Teflon ball and socket. This requires a sharp tool with a large amount of rake in order to shear the Teflon.

We would like to thank J. Wichman for machine work and A. McDonald for consultation on thread selection.

¹L. M. Matarrese, J. S. Wells, and R. L. Peterson, *J. Chem. Phys.* (to be published).

²A. R. Cook, L. M. Matarrese, and J. S. Wells, *Rev. Sci. Instr.* **35**, 114 (1964).

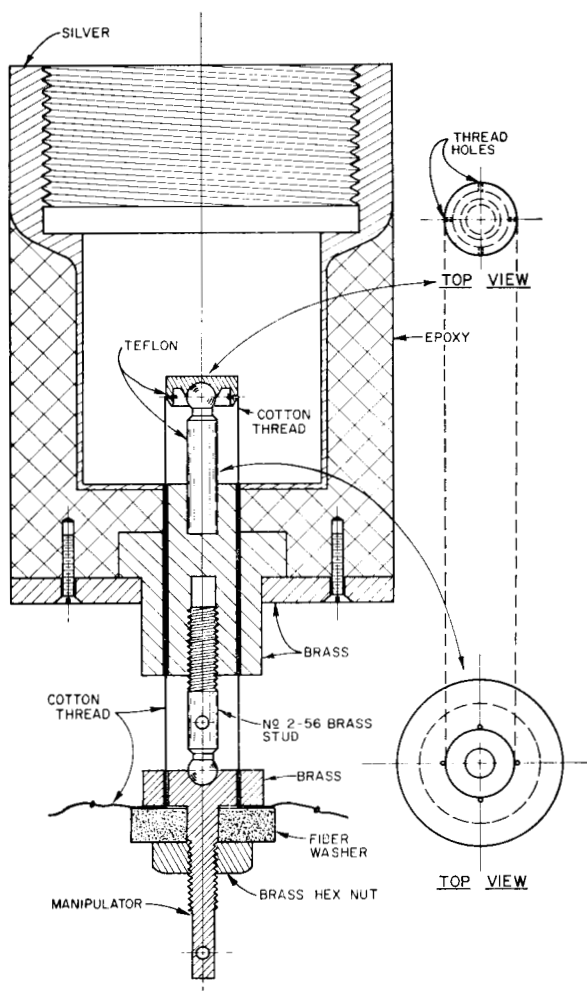

FIG. 1. Sketch of a cross section through the center of sample orienter in a 16.8 mm diam K band microwave cavity which indicates relative sizes. The orienter is held in place by a brass (or other non-magnetic material) washer which is screwed to the epoxy cavity.