

Power Splitter Thermal Noise Correlations in Cross-spectrum Noise Measurements

Archita Hati, Craig W. Nelson and David. A. Howe
 Time and Frequency Division
 National Institute of Standards and Technology
 Boulder, CO/USA
 Email: archita.hati@nist.gov

C. F. Magnus Danielson
 Net Insight AB
 Stockholm, Sweden
 Email: magnus@rubidium.se

Abstract—We discuss collapse of the cross-spectrum phase noise measurement of thermally-limited oscillator due to anti-correlated thermal noise of the Wilkinson power splitter. We also examine effect of thermal noise of various resistive power splitters on such noise measurements. In addition, we introduce a novel technique to solve the cross-spectrum collapse.

Keywords—anti-correlation; cross-spectrum; oscillator; phase inversion; phase noise; power spectral density; thermal noise

I. INTRODUCTION¹

The cross-spectrum technique is widely used for the measurement of phase and amplitude fluctuation noise of oscillators [1]–[4]. This technique is susceptible to experimental errors [5], [6]. One among many of these errors is caused either by positive or negative correlations resulting in over-estimation or under-estimation of the oscillator noise [7], [8]. One cause of the noise under-estimation as explained in [8] can occur due to the anti-correlation (phase-inversion) collapse mainly from AM noise leakage.

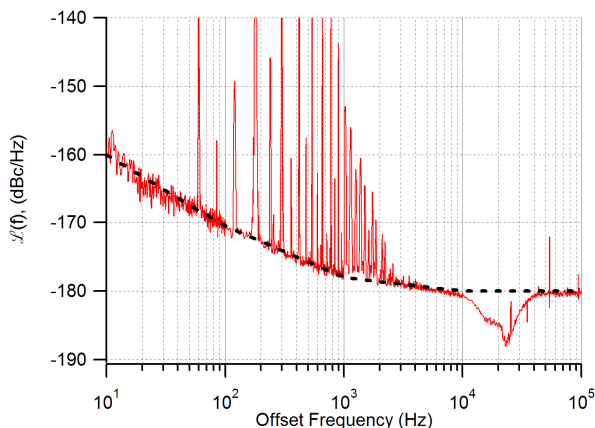

Fig. 1. Single sideband phase noise, $\mathcal{L}(f)$ of a 5 MHz oscillator, showing the effect of anti-correlation around a 20 kHz offset. The dotted line represents the theoretical curve.

The spectrum-collapse may occur only at localized offset frequencies or over a wide range of frequency. An example of localized collapse of the phase noise for a 5 MHz quartz-crystal oscillator is illustrated in Fig. 1; it displays noise collapse around a 20 kHz offset frequency.

More recently, a different source of anti-correlation in a cross-spectrum measurement has been identified; originating from the common-mode power splitter [9]–[11]. Correlated thermal noise of the power splitter appears equally but in opposite phase in two channels of the cross-spectrum system. We will discuss the effect of thermal noise of various reactive and resistive power splitters on the noise measurement of thermally-limited oscillators. Here, we will also demonstrate that the spectrum collapse due to power splitter thermal noise is not localized but occurs over a wider frequency range.

II. CROSS-SPECTRAL COLLAPSE DUE TO POWER SPLITTERS

In recent years, several commercial ultra-low phase noise (ULPN) oscillators have been introduced that operate near the thermal limit. In this new class of oscillators, the bias (either positive or negative) from the power splitter thermal noise plays a dominant role.

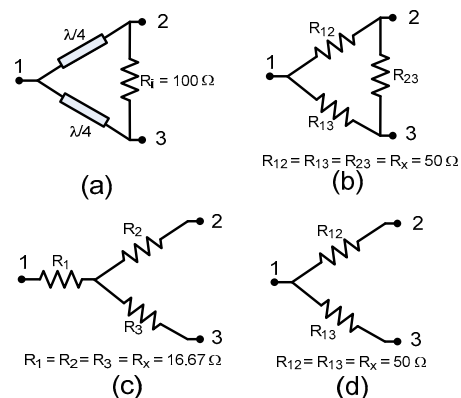

Fig. 2. Schematic of (a) Wilkinson power splitter, (b) Resistive 3-R (Delta configuration), (c) Resistive 3-R (Wye configuration), and (d) Resistive 2-R.

In order to study the effect of thermal noise of the common mode power splitter on absolute phase noise measurements, a selection of reactive and resistive power splitters as shown in Fig. 2 were tested with an ultra-low-phase noise oscillator at

¹Contribution of the U.S. government, not subject to copyright.

100 MHz [Golden Citrine from Wenzel Associates, Inc.²]. The measurement set-up as shown Fig. 3 was used for the phase noise measurement of this oscillator marked as ‘DUT’ (Device Under Test). The phase noise measurements were initially performed without the optional isolators at the output of the power splitter. A variable dc offset voltage was added at the input of the phase locked loop (PLL) integrator to optimize the rejection of the DUT amplitude modulation (AM) noise. The AM noise of the DUT was rejected by 20 dB or more to minimize the effect of anti-correlation collapse due to the AM noise leakage. At first a Wilkinson power splitter (WPS) was chosen and the phase noise of the oscillator was measured with a 3 dB attenuation at the output of the oscillator. Assuming a 50 Ω system, and taking into account the DUT power loss in the impedance matching and harmonic filtering (IMHF) circuit in the common path, the theoretical noise of a thermally-limited oscillator should be -188.3 dBc/Hz i.e., $-177 - P_{PS}$. As shown in Fig. 4, a complete collapse (limited by the number of FFT averages) of the thermal noise spectrum was observed due to the anti-correlated noise of the WPS.

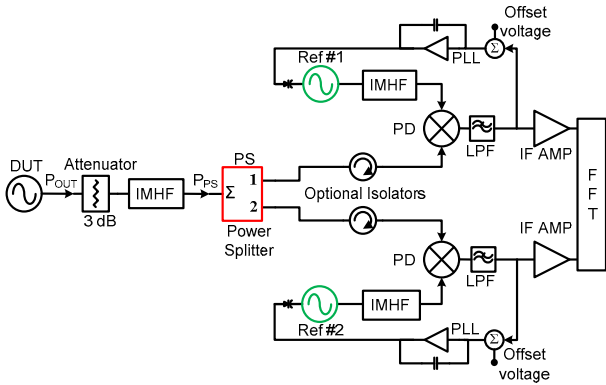

Fig. 3. Block diagram of a cross-spectrum phase noise measurement system. DUT– Device Under Test, IMHF – Impedance Matching and Harmonic Filtering, LPF – Low Pass Filter, PD – Phase Detector, FFT- Fast Fourier Transform, PLL – Phase Locked Loop.

The PM noise of the same oscillator was also measured with 3-R and 2-R resistive power splitters and the results are shown in Fig. 5. The measured thermal noise is almost 3 dB lower than the simulated noise levels (Table 1) in each case. This discrepancy is due to the fact that the simulations were performed with an ideal 50 Ω load impedance; however, in actual experiment the power splitter was connected to the reactive load of the double balanced mixer used as a phase detector. In spite of the discrepancy between measurement and the simulation, the relative difference in the measured thermal noise levels between 3-R and 2-R power splitters is nearly the same as the simulation. In [11], we demonstrated that if the power splitter is connected to real 50 Ω load impedance, the simulation and experimental results agree well, we verified this for the AM noise measurements.

² Commercial products are indicated in this document, no endorsement is implied.

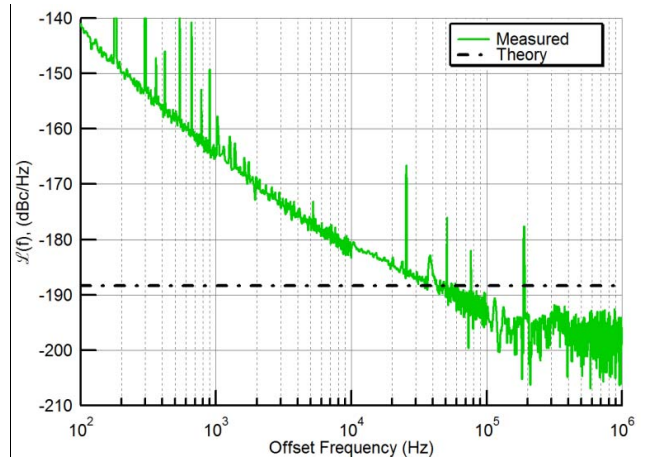

Fig. 4. Phase noise of a 100 MHz oscillator measured with a Wilkinson power splitter (WPS). Theoretical noise of this oscillator referenced to the input power of common-mode power splitter, P_{PS} is -188.3 dBc/Hz calculated from $(-177 - P_{PS})$ assuming a 50 Ω system. The far-from-the-carrier noise is limited by the maximum FFT number, $N = 100,000$ available on the analyzer but there is clear indication of a spectrum collapse.

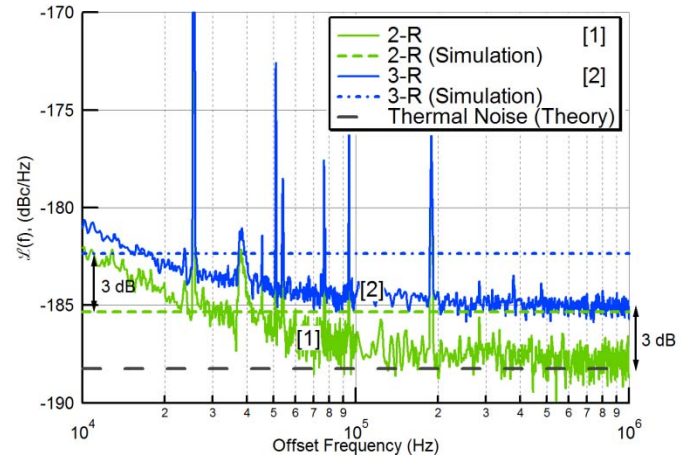

Fig. 5. Phase noise of a 100 MHz oscillator measured with resistive 2-R and 3-R power splitters. The simulated noise for different power splitters is obtained from Table 1, column 10.

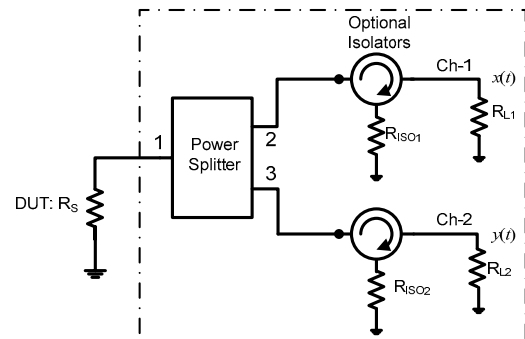

Fig. 6. The main sources of thermal noise used for ADS simulation. R_s represents the thermal noise of the source or the device under test (DUT). Total number of resistors in the power splitter varies from one to three depending on the configuration. Optional isolators, with thermal resistances are indicated by R_{ISO1} and R_{ISO2} . The load resistors R_{L1} and R_{L2} represent the thermal noise of the measurement system.

The simulation results given in Table 1 for different types of power splitters were performed in the Advanced Design System (ADS) software. The block diagram for the simulation is shown in Fig. 6. For this simulation, the thermal noise contribution of the source, the power splitter, isolators and the load resistors are considered. A detailed description of the simulation can be found in [11]. Table 1 lists the thermal noise contributions of the individual components to the output cross-spectrum as a fraction of the noise from R_s . The simulation is performed for load and source impedances equal to 50Ω and at 300 K temperature. The values reported in the table are from the expected value of the cross-spectrum. All uncorrelated cross-terms, which reside in the imaginary component of the cross-spectrum, are zero and the result is an entirely real number. For an exact measurement of the thermal noise of an oscillator, columns three and ten should be equal.

Table 1: 2-way Power Splitter (PS): Source impedance (Z_s) = Load Impedance (Z_L) = 50Ω , $T = 300 \text{ K}$, Isolator: Insertion Loss = 0 dB , Isolation = ∞

Case #	Type of Power splitter (PS)	Relative cross-spectrum of individual component $S_{Ch2-Ch1}(f)/S_{R_s}(f)$								Total Noise	
		R_s	Power Splitter			R_{ISO1}	R_{ISO2}	R_{L1}	R_{L2}	w/o R_s	All Components
			R_1	R_2	R_3						
1	Wilkinson $R_x = 100 \Omega$	1	-1			-	-	0	0	-1	0
2	3-R Wye $R_x = \sim 17 \Omega$	1	1/3	-2/3	-2/3	-	-	2	2	3	4
3	3-R Wye $R_x = \sim 17 \Omega$ Isolators	1	1/3	-2/3	-2/3	0	0	0	0	-1	0
4	3-R Delta $R_x = 50 \Omega$	1	0	-1	0	-	-	2	2	3	4
5	3-R Delta, $R_x = 50 \Omega$ Isolators	1	0	-1	0	0	0	0	0	-1	0
6	2-R $R_x = 50 \Omega$	1	0	-3/4	-3/4	-	-	5/4	5/4	1	2
7	2-R $R_x = 50 \Omega$ Isolator	1	0	-3/4	-3/4	1/4	1/4	0	0	-1	0

Here, R_1 and R_x respectively, correspond to the isolation resistor and the resistors for 2-R and 3-R power splitters.

The simulation results in Table 1 indicate that the 3-R (Delta or Wye) and 2-R splitters produce anti-correlated thermal noise between the outputs. Also, the resistive power splitters do not have sufficient isolation to allow a cross-spectrum measurement to overcome the loss of signal-to-noise ratio in each individual channel. They cannot be used to accurately measure a thermally limited source because the dominating noise of the load to the power splitter appears correlated in both channels and cannot be rejected.

Next, the optional isolators were introduced at the output of 2-R and 3-R power splitters and we observed spectrum collapse in each case as shown in Fig. 7. These isolators prevent the reflected noise of the load resistors from appearing on the other channel. Thus, the correlated thermal noise of the source perfectly cancels with the anti-correlated thermal noise of the power splitter. The measured noise matches with the simulation results given in Table 1.

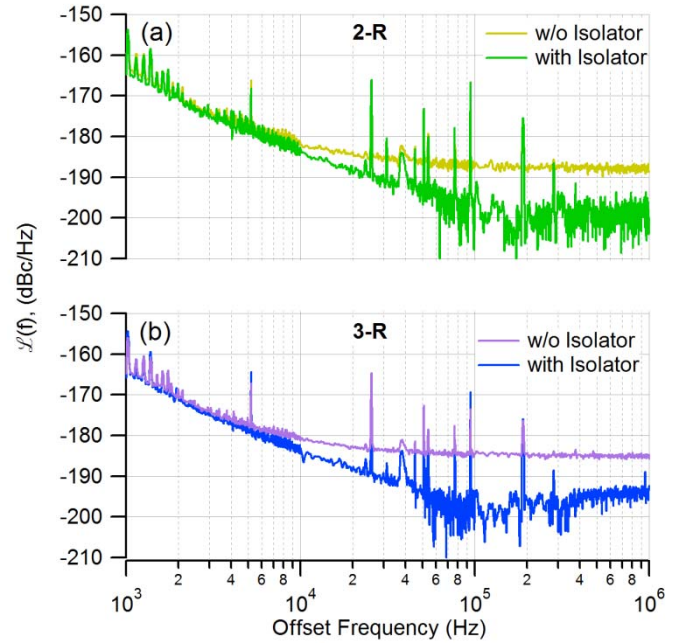

Fig. 7. Phase noise of a 100 MHz oscillator measured with resistive 2-R 3-R power splitter with and without the isolators.

III. TECHNIQUE TO PREVENT CROSS- SPECTRUM COLLAPSE

A new technique to mitigate the cross-spectral collapse due to anti-correlated thermal noise of power is presented. It uses a cross-correlation interferometer based on the Wilkinson power-splitter modified by removing the isolating resistor, R_i as shown in Fig. 8a.

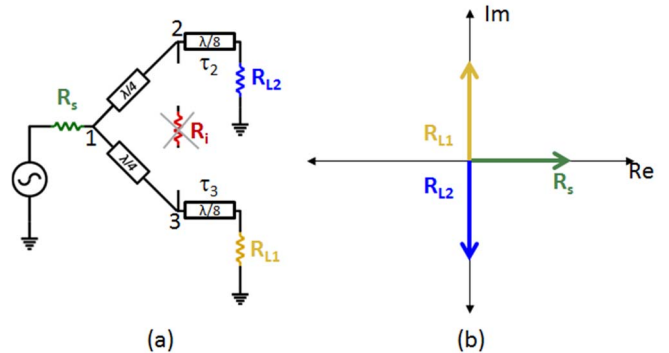

Fig. 8 (a) Cross-correlation interferometer setup for rotating the noise of load resistors R_{L1} and R_{L2} onto the imaginary axis while the source noise R_s remains on the real. (b) Vector diagram of the noise components in the modified power-splitter

Removal of this resistor eliminates the anti-correlated noise source, but degrades the isolation between two output ports. This causes the load resistors noise to leak from port 2 to port 3 and vice versa. The leakage noise of the load resistors R_{L1} and R_{L2} is mitigated by adding a controlled amount of delay ($\tau_1 = \tau_2 = \lambda/8$) at the output ports as illustrated in Fig. 8a. This delay rotates the undesired noise to the imaginary axis while

the desired DUT noise remains on the real axis; the vector diagram of this effect is shown in Fig. 8b. An additional benefit of this technique is that leakage noise of the load resistors R_{L1} and R_{L2} appear on the imaginary axis with opposite sign and thus cancel. This concept has proven to be useful as illustrated by the phase noise plot in [12].

IV. CONCLUSION

We presented simulation and experimental results of cross-spectral collapse due to anti-correlated thermal noise of the common-mode power splitter in a cross-spectrum noise measurement system. We also proposed a technique that prevents such collapse.

REFERENCES

- [1] W. F. Walls, "Cross-correlation phase noise measurements," in *Frequency Control Symposium, 1992. 46th., Proceedings of the 1992 IEEE*, 1992, pp. 257–261.
- [2] D. Fest, J. Gros Lambert, and J.-J. Gagnepain, "Individual Characterization of an Oscillator by Means of Cross-Correlation or Cross-Variance Method," *IEEE Trans. Instrum. Meas.*, vol. 32, no. 3, pp. 447–450, 1983.
- [3] E. Rubiola and V. Giordano, "Correlation-based phase noise measurements," *Rev. Sci. Instrum.*, vol. 71, no. 8, pp. 3085–3091, 2000.
- [4] F. L. Walls and E. Ferre-Pikal, "Measurement of Frequency, Phase noise and Amplitude noise," in *Wiley Encyclopedia of Electrical and Electronics Engineering*, 1st ed., vol. 12, 24 vols., Wiley-Interscience, 1999, pp. 459–473.
- [5] A. K. Poddar, U. L. Rohde, and A. M. Apte, "How Low Can They Go?: Oscillator Phase Noise Model, Theoretical, Experimental Validation, and Phase Noise Measurements," *IEEE Microw. Mag.*, vol. 14, no. 6, pp. 50–72, Sep. 2013.
- [6] U. L. Rohde and A. K. Poddar, "Phase noise measurement techniques, associated uncertainty, and limitations," in *European Frequency and Time Forum International Frequency Control Symposium (EFTF/IFC), 2013 Joint*, 2013, pp. 438–441.
- [7] C. W. Nelson, A. Hati, and D. A. Howe, "Phase inversion and collapse of cross-spectral function," *Electron. Lett.*, vol. 49, no. 25, pp. 1640–1641, Dec. 2013.
- [8] C. W. Nelson, A. Hati, and D. A. Howe, "A collapse of the cross-spectral function in phase noise metrology," *Rev. Sci. Instrum.*, vol. 85, no. 2, p. 024705, Feb. 2014.
- [9] J. Gorin, "Power splitter anti correlation, Cross-spectrum L(f) workshop," 2015 *Joint Conference of the IEEE International Frequency Control Symposium and European Frequency and Time Forum*, Denver, CO, USA, 12-Apr-2015.
- [10] A. Hati, C. W. Nelson, and D. A. Howe, "Effect of anti-correlation on cross-spectrum measurements of thermally limited oscillators," presented at the 8th Symposium on Frequency Standards and Metrology 2015, Potsdam, Germany, 12-Oct-2015.
- [11] A. Hati, C. W. Nelson, and D. A. Howe, "Cross-spectrum Measurement of Thermal-noise Limited Oscillators," *Rev. Sci. Instrum.*, vol. 87, no. 3, p. 034708, 2016.
- [12] C. F. M. Danielson, C. W. Nelson, A. Hati, and D. A. Howe, "Cross-correlation interferometry for phase-noise measurements," *in Press*.