

Phase-Noise Measurement of a 670 GHz Source

J. A. DeSalvo, A. Hati, C. Nelson, and D. A. Howe

Time and Frequency Division
National Institute of Standards and Technology
Boulder, CO 80305 USA
E-mail: desalvo@nist.gov

Abstract—We present phase-noise measurements in support of terahertz electronics. Using digital phase-noise measurement techniques and an even-harmonic mixer, we achieve a phase-noise measurement system in waveguide (WR1.5). At 670 GHz an upper bound of this system’s noise floor is found to be -20, -40, and -60 dBc/Hz at 1, 100, and 10000 Hz offsets, respectively. In addition, a commercial, low-phase-noise, 670 GHz source is measured at offset frequencies from 0.1 Hz to 1 MHz.

I. INTRODUCTION

Low-phase-noise continuous-wave (CW) signals at terahertz frequencies are important in molecular spectroscopy [1,2], imaging [3,4], high-bandwidth communications [5], and space-based radar [6]. Preserving phase stability is essential for these technologies to progress. Up to now, phase-noise estimates at terahertz (THz) frequencies beyond 125 GHz [1,7,8] have been extrapolated from geometric scaling of lower-frequency measurements due to a lack of available instrumentation [9]. The metrology community is motivated to develop terahertz phase-noise measurement capabilities in order to assure characterization of noise for applications that would integrate terahertz components into usable products. NIST is developing phase-noise measurement systems that support 670 GHz, 850 GHz, and 1.05 THz. In this document we present a phase-noise measurement system with a carrier frequency range of 550 GHz to 725 GHz. We report an upper bound on the measurement system noise floor in addition to a phase-noise measurement of a commercial, low-noise, 670 GHz, CW source at offset frequencies from 0.1 Hz to 1 MHz. In addition, we describe our plans to characterize the phase-noise of a WR1.5 harmonic mixer and a 670 GHz amplifier.

II. MEASUREMENT SYSTEM DESCRIPTION

A single-channel measurement system diagram is shown in Fig. 1. The terahertz signal to be measured enters an even-harmonic mixer via WR1.5 waveguide, or optionally via a feedhorn. Aside from the terahertz-band mixer that down-converts to a convenient intermediate frequency (IF), the local oscillator’s (LO) phase-noise sets the measurement noise floor. To serve as our LO reference, we have designed a 2.5 GHz frequency comb with discrete “teeth” selectable via an yttrium iron garnet (YIG) tunable filter up to 50 GHz. This reference strategy provides adequate frequency agility, few spurs, and high power-per-harmonic number. The IF signal is

then amplified, filtered, frequency-divided, and sampled with a digital phase-noise measurement system [13].

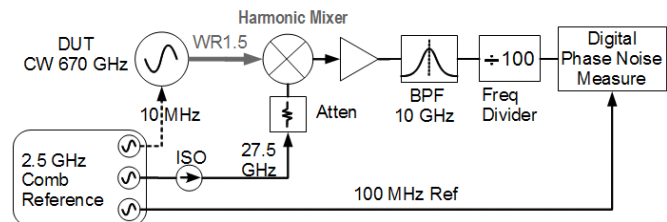

Figure 1. Measurement setup for a 670 GHz source. ISO: isolator, Atten: attenuator, BPF: band-pass filter, DUT: device under test

The comb reference uses a 2.5 GHz step-recovery diode (SRD) to generate the frequency comb from a low-phase-noise 2.5 GHz dielectric resonator oscillator (DRO). The DRO is phase-locked to a 100 MHz quartz oscillator, which in turn is phase-locked to a 5 MHz quartz oscillator. Beyond the bandwidth of each phase-lock, the controlled oscillator maintains a lower phase-time power spectral density, $S_x(f)$, than the local reference, and vice-versa, within the bandwidth of each phase-lock [10]. Recall that $S_x(f)$ is a frequency-normalized version of the one-sided power spectral density of the phase fluctuations, $S_\phi(f)$ [11]:

$$S_x(f) = \frac{1}{(2\pi\nu_o)^2} S_\phi(f)$$

Here ν_o represents the carrier frequency. We achieve the benefits of the lowest phase-time power spectral density of each oscillator in the chain by phase-locking at strategic bandwidths.

III. PHASE-NOISE MEASUREMENTS

Our single-channel measurement, designated PNM14, yields the combined phase-noise from a 670 GHz source and a WR1.5 harmonic mixer at offset frequencies from 0.1 Hz to 1 MHz. Later in this section, we demonstrate that the harmonic mixer is not contributing to this result. We choose 27.5 GHz as the LO frequency producing a 10 GHz IF beat from the 24th mixer harmonic and the 670 GHz signal. After

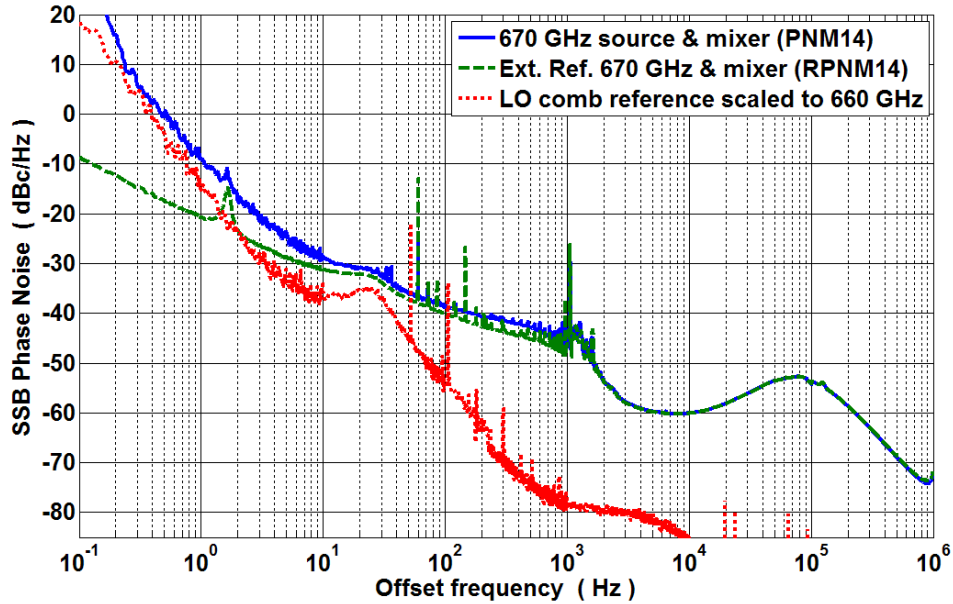

Figure 2. Phase-noise measurements at 670 GHz.

amplification and filtering, we divide the IF frequency by 100. The resulting 100 MHz signal is digitally sampled and phase compared to the 100 MHz reference, which is phase-coherent to the comb synthesis chain below 10 kHz. By use of digital cross-spectrum techniques [12, 13] the noise from sampling and digitizing is reduced, resulting in a direct computation of the phase-noise. The result from PNM14 differentiates between the reference noise floor and the combined noise of the source and harmonic mixer. Plotted as a dotted line in Fig. 2 is the phase-noise of the 27.5 GHz LO reference scaled up to 660 GHz, which constitutes the reference noise floor of the measurement system. The combined noise of the 670 GHz source and harmonic mixer is shown as the solid line.

We are able to tighten the upper bound on the phase-noise of the mixer by externally locking the source to the common 10 MHz signal within our LO comb reference. This residual phase-noise measurement (RPNM14), shown as a dashed line in Fig. 2, represents the phase-noise of the harmonic mixer in addition to synthesis processes in the source that occur after the external phase-lock or beyond the phase-lock bandwidth, such as the multiplier chain. Between 0.1 Hz and 10 Hz, RPNM14 is below PNM14 and exhibits a flicker-phase-noise process, $1/f$ slope. It follows that PNM14 has no contribution from the harmonic mixer at offset frequencies below 10 Hz. While the source was externally locked, the digital phase-noise measurement was verified at baseband above 10 Hz offsets by use of double-balanced, quadrature mixing at 100 MHz and a single-sideband phase-gain calibration [14].

Week-to-week variations of PNM14 were at most ± 2.0 dBc/Hz. These variations were noted at offset frequencies below 10 Hz and were likely dominated by environmental variations affecting the source. RPNM14 produced more

consistent week-to-week results, varying at most by ± 0.5 dBc/Hz. The noise floor of the digital phase-noise measurement system is more than 60 dB below either measurement and has not been plotted in Fig. 2. Self-calibration of the digital phase-noise measurement system shows that its 1σ error is at most ± 0.2 dBc/Hz [13].

In order to demonstrate that PNM14 had no contribution from the harmonic mixer at offsets above 10 Hz, we perform the baseband cross-spectrum PM noise measurement shown in Fig. 3. Uncorrelated noise from the two-channels will average out of the cross-spectral fast Fourier transform (FFT). One limitation of this strategy is that it requires long averaging periods and thermal drift will eventually shift the inputs to the phase detector away from the calibrated quadrature setting. Because of this limitation, the resulting measurement, accurate to ± 2 dBc/Hz, was valid only from 10 Hz to 1 MHz offsets. The results demonstrated two perfectly correlated channels practically identical to the single-channel measurement (RPNM14) from 10 Hz to 1 MHz offsets, indicating that our harmonic mixer is not contributing to PNM14 over this offset frequency range. In combination with RPNM14, we conclude that the harmonic mixer does not contribute to PNM14, so we have successfully measured the phase-noise of this 670 GHz source from 0.1 Hz to 1 MHz.

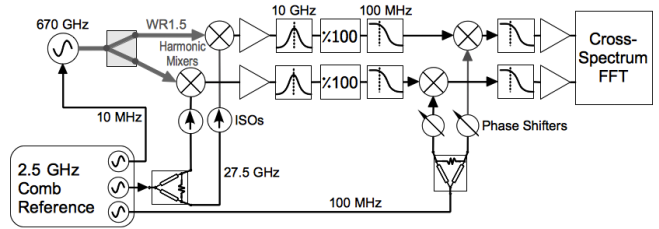

Figure 3. Baseband cross-spectrum PM measurement for a 670 GHz source. ISOs: isolators

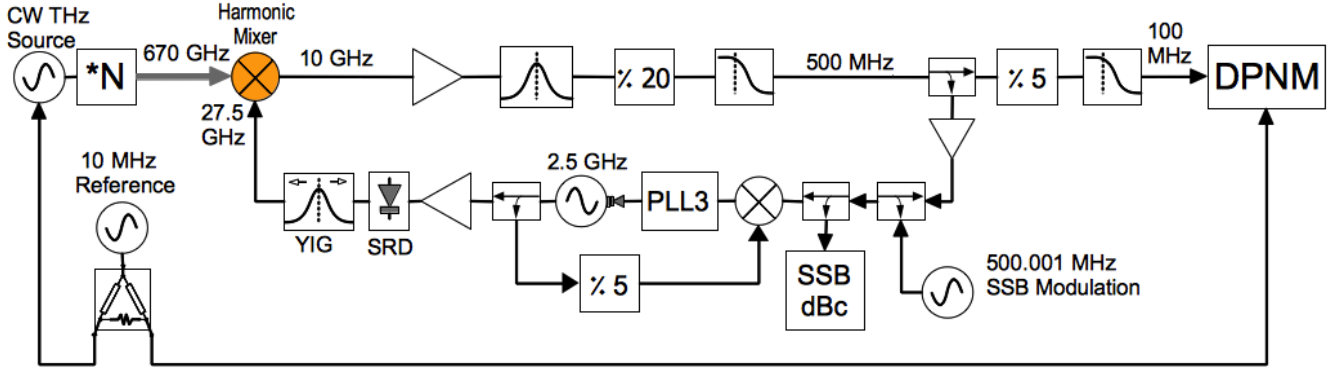

Figure 4. Phase-noise measurement of WR1.5 harmonic mixer. YIG: yttrium iron garnet voltage controlled filter, SRD: step-recovery diode, SSB dBc: relative power measurement of the single side-band modulation, DPNM: digital phase-noise measurement

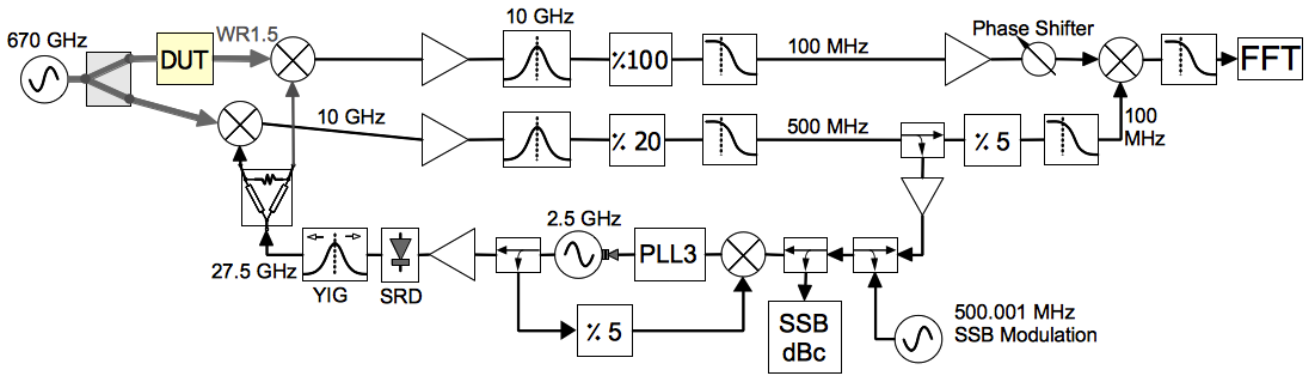

Figure 5. Residual phase-noise measurement of 670 GHz amplifier. YIG: yttrium iron garnet voltage controlled filter, SRD: step-recovery diode, SSB dBc: relative power measurement of the single side-band modulation, DPNM: digital phase-noise measurement, DUT: device under test

IV. DISCUSSION

We note that the LO comb reference is only a few decibels below PNM14 for offsets below 1 Hz, as well as between 20 to 30 Hz, where the comb reference transitions to the 100 MHz cleanup oscillator. This is to be expected, because the 670 GHz source uses technology similar to that inherent in the reference. Nevertheless, the reference appears to be superior enough to conclude that, within a few decibels, PNM14 successfully measured this quality 670 GHz source combined with the harmonic mixer for offsets from 0.1 Hz to 1.0 MHz. Furthermore, our cross-spectral measurement and RPNM14 together demonstrate that the harmonic mixer makes no contribution to PNM14.

Between 0.1 Hz and 10 Hz offsets, RPNM14 demonstrates a flicker-phase-noise process, $1/f$ slope, whereas the source shows a white-frequency process with slope of $1/f^3$. We can conjecture that the dip behavior at offsets above 1.0 kHz is due to a cleanup phase-lock loop (PLL) process within the 670 GHz source, indicating that our measurement system has better performance than can be verified with this source.

The next natural step is to measure the residual phase-noise of the harmonic mixer in order to establish the noise floor for future measurements. We plan to implement the measurement shown in Fig. 4. The most important distinction of this scheme is that we are phase-locking our 2.5 GHz comb directly to the 670 GHz signal. We refer to this as locking at the top of the source synthesis chain. The previous measurement allowed for a 10 MHz external reference locking at the bottom of the synthesis chain. Processes beyond the lock point, such as the frequency multiplier explicitly shown in Fig. 4, are free to inject their own noise and drift independent of the phase-lock. These processes proved to inject substantially more phase-noise than the harmonic mixer.

We can achieve the frequency conversion needed to phase-lock directly to the 670 GHz source by appropriating components from our 2.5 GHz comb reference, including the 2.5 GHz DRO, the 2.5 GHz SRD comb generator, and the YIG voltage controlled filter. The phase comparison occurs at 500 MHz and is processed with a second-order, type 2 PLL. We include equipment to inject a single side-band (SSB) modulation and measure the relative SSB power at 500 MHz in order to calibrate the PLL gain. As we increase the

bandwidth we reduce the phase error between the 670 GHz source and the comb. Eventually we will be left with the noisiest component in the loop, which we anticipate to be the harmonic mixer.

Finally, we hope to accomplish residual phase-noise measurements in WR1.5 waveguide. If another terahertz source were to come available with significantly less synthesis noise, we might be able to implement a residual measurement with the schematic similar to Fig. 3 by adding the device-under-test (DUT) to one of the WR1.5 channels. This would establish a cross-correlated residual phase-noise measurement system in WR1.5 waveguide. Lacking the patience for this eventuality, we propose the arrangement shown in Fig. 5. Here we have the same phase-locking configuration as presented in Fig. 4 but with the addition of a synchronous down-converting arm that includes the DUT in either WR1.5 waveguide or freespace. Because the arms are synchronous, we may obtain a quadrature condition and evaluate the phase-noise. It is anticipated that the harmonic mixers will limit the noise floor of this residual phase-noise measurement system.

V. CONCLUSIONS

We conclude that at 670 GHz our phase-noise measurement system achieves a noise floor of at most -10, -20, -40, and -60 dBc/Hz at 0.1, 1, 100, and 10000 Hz offsets, respectively. In addition, we have successfully measured a 670 GHz source in WR1.5 waveguide at offset frequencies from 0.1 Hz to 1 MHz. Our immediate plans include a phase-noise measurement of a 670 GHz even-harmonic mixer as well as a 670 GHz amplifier. Future work will extend the measurement range to higher carrier frequencies.

ACKNOWLEDGMENT

We thank Dylan Williams and Denis LeGolvan of the NIST Electromagnetics Division for the use of their lab space and equipment.

REFERENCES

- [1] S. Ho-Jin, N. Shimizu, T. Furuta, K. Suizu, H. Ito, and T. Nagatsuma, "Broadband-Frequency-Tunable Sub-Terahertz Wave Generation Using an Optical Comb, AWGs, Optical Switches, and a Uni-Travelling Carrier Photodiode for Spectroscopic Applications," *Lightwave Technology*, Journal of, vol. 26, no. 15, pp. 2521-2530, Aug. 1, 2008.
- [2] M. Theuer and J. Melinger, "High Resolution Waveguide Terahertz Time-Domain Spectroscopy," *J. Infrared Milli. Terahz. Waves*, vol. 32, no. 11, pp. 1267-1284, Aug. 21, 2011.
- [3] J. F. Federici, D. Gary, B. Schulkin, F. Huang, H. Altan, R. Barat, and D. Zimdars, "Terahertz imaging using an interferometric array," *Applied Physics Letters*, vol. 83, no. 12, pp. 2477-2479, Sep. 2003.
- [4] J. D. Chisum, E. N. Grossman, and Z. Popovic, "A general approach to low noise readout of terahertz imaging arrays," *Review of Scientific Instruments*, vol. 82, no. 6, pp. 065106-065106-8, June 2011.
- [5] T. Kleine-Ostmann and T. Nagatsuma, "A Review on Terahertz Communications Research," *J. Infrared Milli. Terahz. Waves*, vol. 32, no. 2, pp. 143-171, Jan. 11, 2011.
- [6] M. Shur, "Terahertz technology: devices and applications," *Solid-State Device Research Conference, ESSDERC 2005. Proceedings of 35th European*, pp. 13- 21, 12-16 Sept. 2005.
- [7] A. Hati, C. W. Nelson, J. F. Garcia Nava, D. A. Howe, F. L. Walls, H. Ascarrunz, J. Lanfranchi, and B. Riddle, "W-band dual channel AM/PM noise measurement system -an update," *Proc. 2005 Joint Mtg. IEEE Intl. Freq. Cont. Symp. and PTTI*, pp.503-508.
- [8] D. A. Howe and J. R. Ostrick, "100-GHz Cooled Amplifier Residual AM and PM Noise Measurements, Noise Figure and Jitter Calculations," *IEEE T. Microw. Theory*, vol. 51, no. 11, pp. 2235-2242, Nov. 2003.
- [9] D. Huang, T. R. LaRocca, M. Chang, L. Samoska, A. Fung, R. L. Campbell, and M. Andrews, "Terahertz CMOS Frequency Generator Using Linear Superposition Technique," *Solid-State Circuits, IEEE Journal of*, vol. 43, no. 12, pp. 2730-2738, Dec. 2008.
- [10] F. Gardner, *Phaselock Techniques*, 3rd ed., New Jersey: John Wiley & Sons, 2005.
- [11] E. Rubiola, *Phase Noise and Frequency Stability in Oscillators*, New York: Cambridge University Press, 2009.
- [12] W. F. Walls, "Cross-Correlation Phase Noise Measurements," *Proc. of IEEE Frequency Control Symposium*, 1992, pp. 257-261.
- [13] J. Grove, J. Hein, J. Retta, P. Schweiger, W. Solbrig, and S. R. Stein, "Direct-digital phase noise measurement," *Proc. 2004 IEEE Int. Freq. Cont. Symp. Exhibit*, Aug. 2004.
- [14] F. L. Walls, "Correlation Between Upper and Lower Noise Sidebands," *IEEE T. Ultrason. Ferr.*, vol. 47, pp. 407-410, Mar. 2000.