

A SIMPLIFIED LASER AND OPTICS SYSTEM FOR LASER-COOLED RB FOUNTAIN FREQUENCY STANDARDS*

P. D. Kunz, T. P. Heavner, and S. R. Jefferts
Time and Frequency Division
National Institute of Standards and Technology
325 Broadway, Boulder, CO 80305, USA
E-mail: kunzp@boulder.nist.gov

Abstract

We are developing a simple and robust laser and optics system suitable for a transportable laser-cooled rubidium (Rb) atomic fountain frequency standard. This system uses DFB (Distributed Feedback) diode lasers and a frequency offset-locking scheme to generate the optical frequencies needed for laser-cooling, launching, post-cooling, and detection of Rb atoms. Here, we describe the early results from this project and the anticipated performance of a compact, transportable Rb fountain frequency standard using this laser system. This system will also be useful for nontransportable laser-cooled atomic frequency standards.

INTRODUCTION

We have begun to develop a transportable laser-cooled Rb fountain microwave frequency standard. We consider “transportable” to mean a physics package of $\sim 1\text{m}^3$ accompanied by a similarly sized electronics rack. Cesium fountain primary frequency standards such as NIST-F1 now achieve fractional accuracies $\sim 4 \times 10^{-16}$, and optical standards promise to perform even better in the near future. However, the time-transfer techniques used to compare spatially separated atomic standards cannot in practice support these accuracies, due to the lengthy averaging time required. Presently, comparing two frequency standards at the 1×10^{-15} level requires 15 days of continuous comparison using common-view GPS. To achieve 1×10^{-16} would require an impractical 150 days of continuous comparison. The transportable frequency standard proposed here would be useful in such comparisons.

A compact and reliable laser-cooled standard would also be useful as a replacement for hydrogen masers in clock ensembles used to generate timescales. Although hydrogen masers are extremely reliable, with lifetimes of 10-20 years of continuous operation, they suffer from frequency drift and unexplained aging mechanisms.

Finally, we expect industry to eventually develop laser-cooled frequency standards as a replacement for the widely used commercial Cs-beam atomic clocks. We view this research as a jumpstart for this effort.

□

* Work of the US government; not subject to US copyright.

Here, we describe the early stages of this program, which has focused on developing a novel laser-optics system that is simple, robust, and capable operating for long periods without user intervention. The foundation of the system rests in our use of distributed feedback (DFB) diode lasers. A master DFB is locked to an atomic transition using the DAVLL (dichroic atomic vapor laser lock) method [1-3]. All slave DFBs are locked to the master by use of an electronic frequency offset-locking scheme to generate the optical frequencies needed for a laser-cooled fountain. The optical delivery system relies heavily on commercial fiber-optic splitters, which further reduces the number of components. For comparison, an optical system competitive with ours would be NASA's PARCS project [4], meant to send a laser-cooled atomic frequency reference into space. Compared with their design, our design eliminates roughly 70% of the components, including 10 fiber collimators, 3 lasers, 14 polarizing beam splitters, 4 isolators, 7 atomic cells, 7 filters, 19 detectors, 13 half-wave plates, 7 quarter-wave plates, 6 double-pass acousto-optic modulators (AOMs), and 6 single-pass AOMs. Eliminating all these components not only reduces the cost and power consumption, but eases assembly and increases stability of the optics package. Finally, we discuss the anticipated performance of a transportable Rb fountain.

DFB LASER AND OPTICS SYSTEM

DFB diode lasers have relatively high output power (~ 100 mW), are stable, and are small (TO-3 Package) compared to an ECDL (extended cavity diode laser) system. While there are many non-DFB diode lasers with high power (>100 mW) at 780 nm that can be built into an ECDL (extended cavity diode laser) with linewidths of <100 kHz, the external cavity has severe thermal and mechanical stability issues. These lead to a continuous tuning range that typically extends only a few gigahertz without encountering a mode-hop. On the other hand, DFB lasers have the advantage that a tuning grating is built into the laser diode itself. The entire DFB fits into a standard TO-3 package, and the continuous mode-hop-free tuning range is many times greater than that of typical ECDLs. Although the linewidths (a few megahertz) are generally not as narrow as the ECDL, this has little impact on the laser-cooling. To mount the DFB diodes, we used a slightly modified commercially available collimating lens package (Thorlabs LDH3-P1⁵) mounted in an aluminum case with protection circuitry and electrical connectors. The modification consists of drilling and tapping three holes for nylon-tipped set screws, that aid in the alignment of the diode to the desired optical axis.

For our laser-cooled atomic fountain operating in the (1,1,1) geometry, we will use four slave lasers plus the master. Two of those slave lasers will be used to create the six cooling (magneto-optical trap or optical molasses) and launching beams such that one is for the three "up" beams and the other for the three "down." The third slave laser will be the repump, and the last one will be dedicated to detection. To cool and then launch atoms, the six molasses beams are initially at the same frequency, about 1.5Γ to the red (i.e., lower frequency) of the cycling transition. (As usual, Γ here represents the natural linewidth of the atomic transition, which in our case is 6 MHz.) In order to launch the atoms, the three "down" beams are then detuned further to the red, and the "up" beams to the blue (i.e. higher frequency), by 5 MHz for 1 ms. The ball of atoms is finally given a post-cool, whereby the frequencies of the beams are swept to the red by ~ 50 MHz in about 1 ms. This requires fast and precise frequency control of the laser beams.

In many fountain systems, this control of the laser frequency has been achieved by taking a high-powered main beam and using AOMs in the double-pass configuration [6] to control the frequency and intensity. While this technique works well in the lab, each double pass set up requires several expensive polarizing optical components (that are sensitive to temperature changes), roughly 1000 cm^2 of table space, precise alignment, and bulky RF power amplifiers (which consume ~ 15 W). Our offset-locking scheme circumvents all of these issues. With a moderate servo loop bandwidth (less than 1 MHz), we can use

digital microcontrollers to individually control each slave laser. Everything from frequency sweeping, to automatic relock, to jumping far off resonance as a possible shutter effect [7] (or in conjunction with a mechanical shutter) can be relegated to simple software programming.

The master reference DFB laser is locked to a Rb optical transition by means of the DAVLL (dichroic atomic vapor laser lock) method. As seen in Figure 1, the DAVLL layout is much simpler than the usual saturation absorption spectrometer. There are fewer optical and electrical components and alignment is trivial. A small amount of linearly polarized light (less than 1 mW) is picked off and directed through a Rb vapor cell. The cell is in a magnetic field that is collinear with the laser beam. The magnetic field Zeeman shifts some of the hyperfine magnetic sublevels up in frequency, and others down. This results in two separate Doppler-broadened peaks that preferentially absorb either right or left circularly polarized light. These two circular polarizations can be extracted from the linearly polarized light by a quarter-wave plate and polarizing beam splitter. One beam is then subtracted from the other, yielding a dispersion curve that can be directly fed back to the diode current source for locking, eliminating the need for any modulation and demodulation stages. The fact that the error signal is Doppler broadened means there is a large lock region that allows the system to compensate for large perturbations. Furthermore, having only a single lock point makes auto-locking easy. The possibility of inferior lock performance due to a Doppler-broadened transition, as opposed to a narrow hyperfine feature, is mediated by the stronger signal strength. In fact, the signal strength compensates for the broader linewidth, such that the product of the signal-to-noise ratio times the linewidth is roughly equivalent to that of a saturated absorption lock.

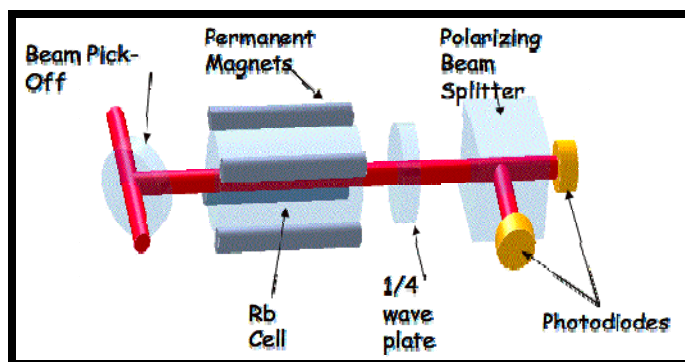

Figure 1. Diagram of a DAVLL system.

A block diagram of the laser and optics system under development is shown in Figure 2, where the slave laser represents one of the four slave DFBs. The four slave lasers are locked to the master laser by means of an offset-locking scheme. Each slave laser is beat against the master laser, and the beat note is detected with a high bandwidth photodiode amplifier. This beat note signal is sent to a frequency/phase detector and compared to a reference. The error signal is fed back onto the slave laser, locking it to the master with frequency offset defined by the reference. All the necessary optical frequencies needed for cooling, launch, and post-cool are produced by changing the frequency of the reference, which can be done rapidly and accurately with a digital microcontroller. As previously mentioned, this scheme eliminates the use of AOMs and high-powered RF sources.

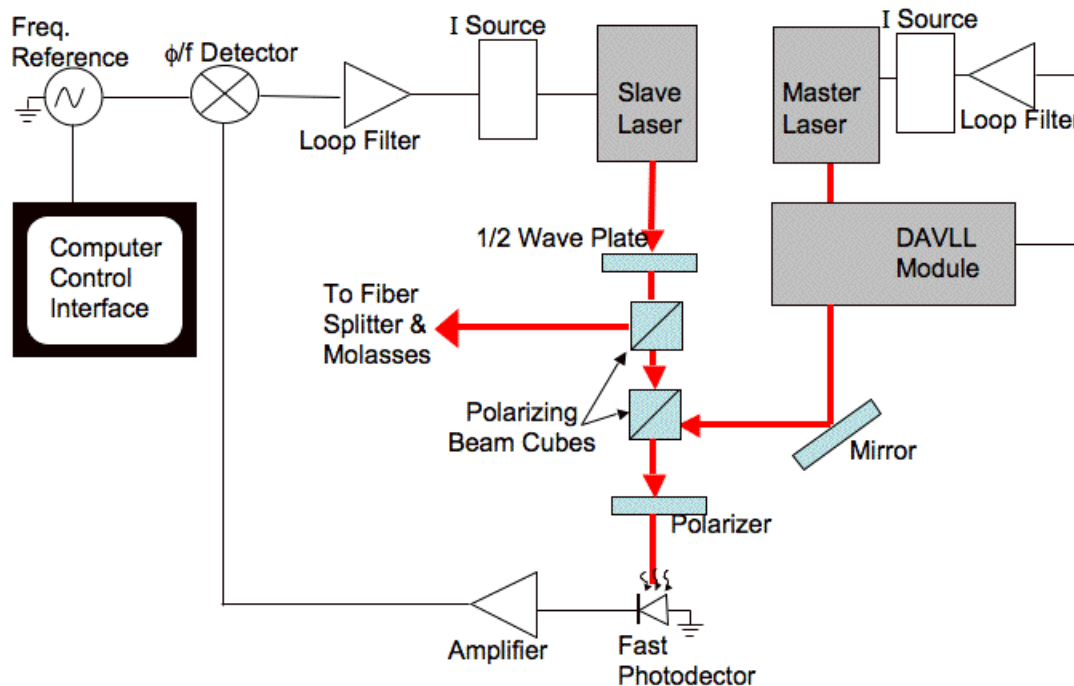

Figure 2. Block diagram of laser and optical system. For clarity, additional duplicate slave lasers are not shown.

Polarization-maintaining fiber optic splitters will be used to divide the power between the three up, as well as the three down, beams. This system uses two fixed splitters (a 50%/50% and a 67%/33%) and two variable-ratio splitters. The fixed splitters provide a coarse adjustment on the power levels, and the fine adjustment is provided by the variable-ratio splitters. This enables the control necessary for power balancing the optical molasses.

PERFORMANCE GOALS

In the fountain geometry, the atoms spend most of the flight time around the trajectory's apogee. This means that relatively long Ramsey times are attainable in small fountain structures. If we assume a 1 m tall physics package with a molasses region built from a ~30 cm diameter vacuum can, and microwave cavities (state selection and Ramsey) with dimensions of 2.54 cm high with a radius of 5.4 cm (this gives a 6.8 GHz resonant frequency), we conclude that this geometry easily allows Ramsey times of ~0.4 s. Given beam radii of 1 cm and 10 mW per beam of power, we expect to load $\sim 10^8$ atoms in ~200 ms. After state selection, we expect to get one fifth of the original atoms in the $F=1, m_F=0$ state. Assuming atom temperatures of ~1.5 cm/s (i.e., a few recoils = 0.58 cm/s) and large apertures of $r \sim 2$ cm in the microwave cavities, essentially all of the atoms will return to the detection region. Given these assumptions, the potential short-term stability is $\sigma_y(\tau \approx 1\text{ s}) \sim 5 \times 10^{-14}$, with a long-term stability of $\sim 10^{-16}$.

REFERENCES

- [1] K. L. Corwin, Z.-T. Lu, C. F. Hand, R. J. Epstein, and C. E. Wieman, 1998, “*Frequency-stabilized diode laser with Zeeman shift in atomic vapor,*” **Applied Optics**, **37**, 3295-3298.
- [2] J. M. Reeves, O. Garcia, and C. A. Sackett, 2006, “*Temperature stability of a dichroic atomic vapor laser lock,*” **Applied Optics**, **45**, 372-376.
- [3] A. Millett-Sikking, I. G. Hughes, P. Tierney, and S. L. Cornish, 2007, “*DAVLL lineshapes in atomic rubidium,*” **Journal of Physics B: Atomic, Molecular, and Optical Physics**, **40**, 187-198.
- [4] D. B. Sullivan, N. Ashby, E. A. Donley, T. P. Heavner, L. W. Hollberg, S. R. Jefferts, W. M. Klipstein, W. D. Phillips, D. J. Seidel, 2005, “*PARCS: NASA’s laser-cooled atomic clock in space,*” **Advances in Space Research**, **36**, 107-113.
- [5] The commercial equipment used has been identified for technical completeness. Such identification does not imply recommendation or endorsement by the National Institute of Standards and Technology.
- [6] E. A. Donley, T. P. Heavner, F. Levi, M. O. Tataw, and S. R. Jefferts, 2005, “*Double-pass acousto-optic modulator system,*” **Review of Scientific Instruments**, **76**, 063112.
- [7] W. M. Klipstein and D. G. Enzer, 2002, “*Mitigation of the light shift in laser cooled clocks without mechanical shutters,*” in Proceedings of the 2002 IEEE International Frequency Control Symposium and PDA Exhibition, 29-31 May 2002, New Orleans, Louisiana, USA (IEEE Publication 02CH37234), pp. 484-487.

