

# Design Concept for the Microwave Interrogation Structure in PARCS

G. J. Dick, W. M. Klipstein

Jet Propulsion Laboratory, California Institute of Technology,  
MS 251-100, 4800 Oak Grove Drive, Pasadena, CA 91109 USA

T. P. Heavner, S. R. Jefferts

Time and Frequency Division, National Institute of Standards and Technology  
325 Broadway, Boulder, CO 80305 USA

**Abstract** – In this paper we describe key aspects of the conceptual design of the microwave interrogation structure in the laser-cooled cesium frequency standard that is part of the Primary Atomic Reference Clock in Space (PARCS) experiment. The PARCS standard uses balls of cold atoms launched in a pulsed beam configuration. The microwave interrogation will take place in two independent high- $Q$  (~20,000) cavities operated in the  $TE_{011}$  mode. The cavities will be operated off resonance by several linewidths, with a resonant coupling structure delivering the microwave to the two cavities. One persistent problem related to the end-to-end phase shift has been the extreme temperature sensitivity of the phase of inside the cavities to that just outside the cavities. The end-to-end phase shift must ultimately be known to around 3 microradians, and stable long enough to allow measurement of the shift as well as to allow normal clock operation. Operating the cavities off resonance reduces this sensitivity more strongly than reducing the cavity  $Q$ .

## I. \* INTRODUCTION

This paper addresses the conceptual implementation of the microwave interrogation structure in the Primary Atomic Reference Clock in Space (PARCS) experiment [1], focusing on the end-to-end phase shift, which has been a dominant systematic frequency offset in atomic beam frequency standards [2]. The advent of laser-cooled atomic fountains eliminated the end-to-end shift as the atoms were interrogated by the same microwave cavity, once on the way up and once on the way back down. PARCS contains a laser-cooled cesium frequency standard designed to operate in the microgravity environment aboard the International Space Station (ISS). This standard shares many of the benefits of a laser cooled standard

\* Part of the research described in this paper was carried out at the Jet Propulsion Laboratory, California Institute of Technology, under a contract with the National Aeronautics and Space Administration. Part of the research described in this paper is work of the United States government, not subject to US copyright.

on Earth, but in the absence of gravity must be operated in a modified beam geometry rather than as a fountain, thus reintroducing the end-to-end phase shift. A schematic drawing of the PARCS cesium physics package is shown in Fig. 1. PARCS has a design goal of measuring the end-to-end shift with an uncertainty of  $2 \times 10^{-17}$ , requiring the phase offset between the cavities to be known with an uncertainty of 3 microradians. The main difficulty comes from small changes in temperature as discussed below. We will show that by operating the cavities off resonance we expect we can meet our operational requirements.

## II. MICROWAVE INTERROGATION STRUCTURE

Microwave interrogation of the balls of cold atoms will take place in two  $TE_{011}$  cylindrical cavities similar to those favored in fountain applications. These cavities allow large holes through the center allowing significant numbers of atoms to get through the cavities, while having desirable phase and intensity flatness and symmetry across the aperture. The cavities are expected to have a quality factor,  $Q$ , of approximately 20,000. The cavities will be detuned from the cesium resonance by approximately  $5\Gamma$ , where  $\Gamma$  is the full-width at half maximum (FWHM) of the cavities. The cavities will be connected by a resonant coupling structure as shown in Fig. 2. The

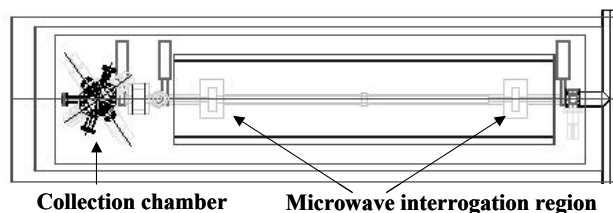

Figure 1 Schematic of the PARCS cesium physics package. Balls of laser-cooled atoms are collected on the left and are launched through the microwave interrogation region, in a pulsed beam tube geometry.

coupling structure itself will have a  $Q$  of around 5000 and be driven by a single microwave source located outside the physics package. The two cavities will be in phase with each other, and phase modulation interrogation will be implemented by switching the phase of the entire structure in between balls of atoms.

In a previous paper [3] we discussed using independent cavity phase control, with phase modulation implemented by reversing the phase in the second cavity between balls. Various implementations of this strategy all had difficulty with the temperature coefficient of the phase inside each cavity. The implementation of off-resonant cavities appears to solve this problem, and we have chosen the current design as our baseline as the most straightforward implementation meeting our requirements on end-to-end phase shift.

### III. MEASUREMENT OF THE END-TO-END PHASE SHIFT

As discussed in [3], in a laser-cooled standard in microgravity it is possible to measure the end-to-end phase shift by varying the atomic velocity and extrapolating to zero velocity. In short, the laser-cooled source has a very narrow velocity distribution with a selectable mean velocity. The end-to-end phase offset is measured by comparing the observed center

frequency at two “fast” launch velocities, such as 5 and 15 m/s. The frequency difference can be attributed to the end-to-end phase offset as for these two velocities all other frequency offsets (other than the calculable second order Doppler shift) are common. With the measured phase offset between the cavities, a correction can be made to the frequency measured with the standard launch velocity of 0.30 m/s. This is shown graphically in Fig. 3.

### IV. TEMPERATURE COEFFICIENT OF THE END-TO-END PHASE

If the end-to-end phase were stable then the offset could be measured only once. With the use of the resonant, relatively high- $Q$  TE<sub>011</sub> cavities, however, there is a strong dependence on the phase inside the cavity,  $\phi_{1,2}$ , with the phase delivered to the cavity,  $\phi'_{1,2}$ , for cavities 1,2 respectively. This phase difference depends on the detuning of the cavity, and hence its temperature, as shown in Fig. 4. With the cavities operated nominally on resonance the slope of the phase difference,  $\Delta\phi = \phi - \phi'$  is a maximum, with a value for our cavities of approximately 1 radian/K. Such sensitivity would require a temperature stability of 3 microKelvin to maintain a stable phase difference at the required level. Such temperature stability is

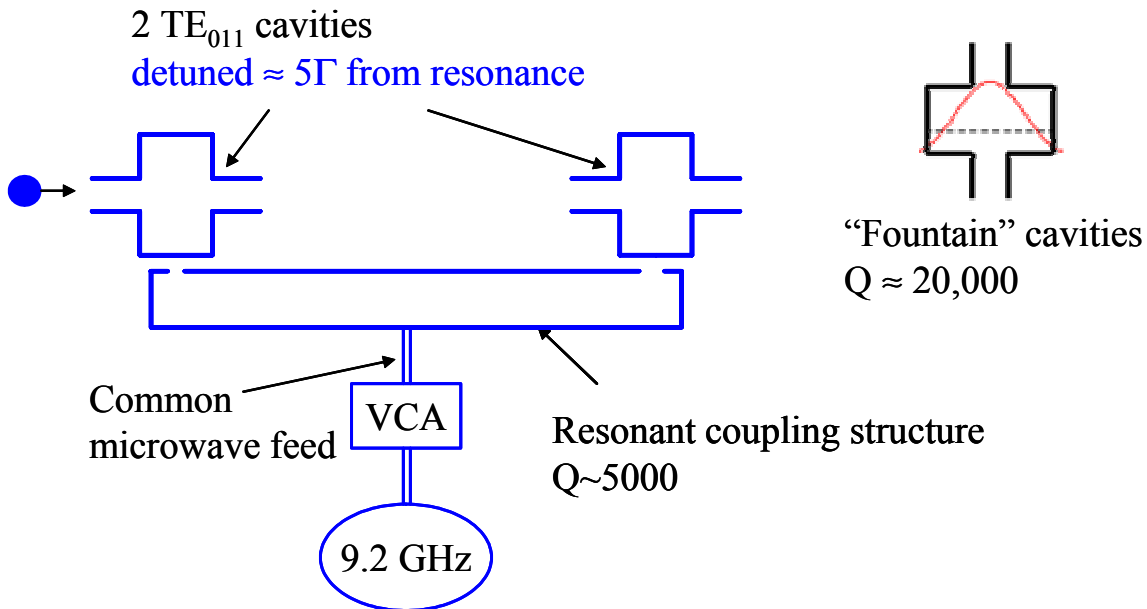

Figure 2 Cartoon of the microwave interrogation structure in PARCS. Atoms are interrogated in two TE<sub>011</sub> cavities fed by a common resonant coupling structure and common microwave feed. Operation of the cavities off-resonant is critical to reducing the temperature coefficient of the end-to-end phase shift. The two cavities will be operated in phase with each other, and the atoms will be interrogated using phase modulation. The curved line inside the fountain cavity represents the field in the cavity.

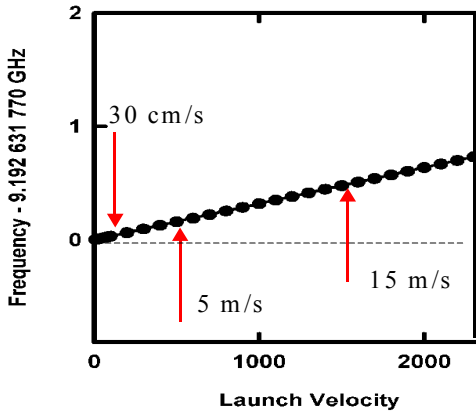

Figure 3 The end-to-end phase difference between the two cavities can be measured by comparing the center frequency at different launch velocities. A correction can then be applied to the measured frequency at the normal launch velocity of 0.3 m/s.

well beyond our capabilities, requiring a nearly continuous monitoring of the end-to-end shift. This would have significant impact on our ability to run in our nominal configuration, especially in light of the need for significant changes in microwave power to match the fast launch velocities and the time-varying phase delays coming from such changes in power.

As can be seen from Fig. 4, the phase slope with detuning (and hence temperature) is dramatically reduced off resonance, reduced essentially as the square of the detuning measured in half line widths. Operating the cavities detuned by  $5\Gamma$ , therefore, reduces the temperature coefficient by 100, at the same time requiring 100 times more microwave power.

## V. COMPARISON OF DETUNING CAVITIES TO REDUCING CAVITY Q

Rather than detuning the cavities, reduction of the phase slope to temperature could also be accomplished by reducing their  $Q$ . Such a scenario is depicted in Fig. 5, which shows a comparison between the reduced- $Q$  case operated on resonance and the use of detuned cavities. In fact, the  $Q$  would have to be reduced by 100 times in order to achieve the reduction in phase slope of our present design. While the RF drive amplitude at the cavity input ports would be similar to the detuned case, this would be real, not reactive power. This power would result in an unacceptable 100 times increase in intra-cavity phase variation, while a corresponding increase in traveling

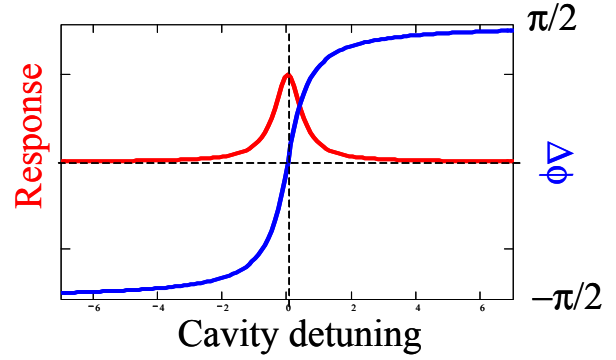

Figure 4 Plot of the cavity response and phase difference,  $\Delta\phi = \phi - \phi'$ , between the inside and outside of the cavity as a function of detuning from the operating frequency.

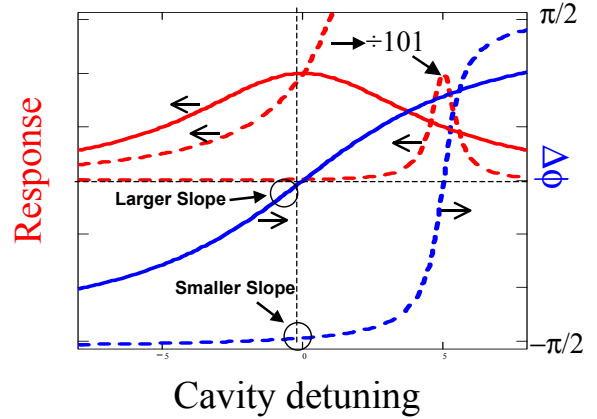

Figure 5 Plot of cavity response and inside-outside cavity phase difference for the case of reduced  $Q$  (solid lines) and for detuned cavities (dashed lines). The cavity response, divided by 101, is also shown since the detuned cavity response is off scale. Arrows point to the relevant axis for each curve. This plot illustrates the benefits of operating with the cavities detuned. The reduction in phase slope for detuned cavities is as the square of the detuning in half line widths, while scaling only linearly in the broadening of the cavity  $Q$ .

wave power in the coupling structure would increase phase variation there as well.

## VI. RESONATING THE COUPLING STRUCTURE

Resonating the coupling structure reduces sensitivity to changes in the lengths of the two arms of the cavity, essentially by the  $Q$ . It also greatly relaxes the requirements on the location of the holes in the structure used to feed the cavities, as the phase becomes relatively flat as a function of location as shown in Fig. 6 below. This reduces the difficulty caused by varying temperature gradients across the structure, which is expected to be approximately 0.75

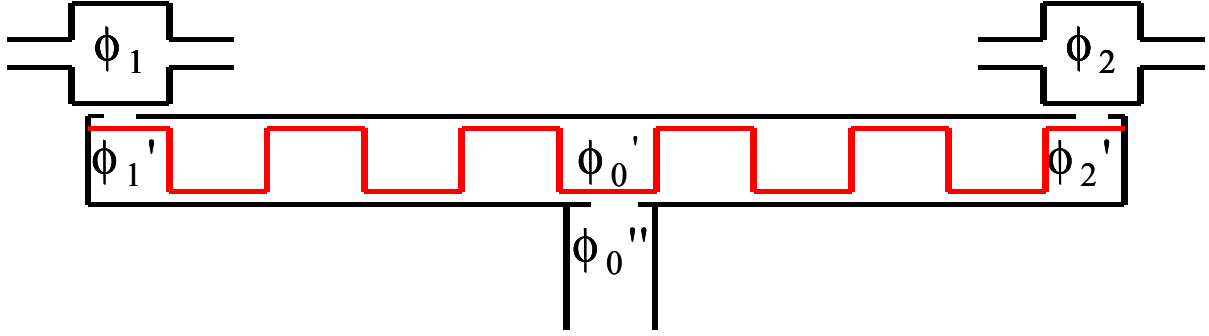

Figure 6 Phase variation in the resonant microwave coupling structure. Resonating this structure creates a phase difference between the inside and outside of the structure that is common to the two cavities. Individual atoms will experience a phase offset if this phase varies during the time of flight between the two cavities.

meters long and has a design requirement allowing the temperature to vary by 50 mK from end to end.

Resonating the coupling structure creates a phase variation,  $\phi'' - \phi'$ , between the inside of the coupling structure and the common feed as shown in Fig. 6. This change in phase will be common mode to the two cavities, so to first order such variations do not cause an error. While the phase change is common mode to the two cavities, it is not common mode to a single atom to the extent that the phase changes in the time it takes for it to travel from the first cavity to the second. For a linear slope of temperature this corresponds to a fixed (but bounded) frequency error. Such a shift would also be present in a fountain, for which a temperature slope of 30 microK/s would correspond to a shift of  $1 \times 10^{-15}$ . Since the temperature is bounded, the average shift would be expected to be zero, but can be finite and potentially large over shorter times.

## VII. DISTRIBUTED CAVITY PHASE SHIFT CONSIDERATIONS

The use of high- $Q$  TE<sub>011</sub> cavities is motivated by several factors, but one is the distributed cavity phase shift, and it behooves us to consider the impact of operating the cavities off resonance, particularly with the 100 times additional power required to drive the atomic resonance. We have considered several different factors, including the geometric phase gradient, port-to-port matching requirements, and the impact of the TM<sub>111</sub> modes. The “geometric” component, depending on the number of cavity feeds and the unloaded cavity  $Q$ , is unchanged, as this is strictly geometric in nature and is perhaps the greatest benefit of high  $Q$  in a cavity. The sensitivity to imbalances of the four cavity ports is increased by the suppression factor of approximately 100, but even

with this enhancement this matching requirement does not seem difficult to meet.

As in fountains, the cavities will be built with mode filters to split out the two TM<sub>111</sub> modes which would otherwise be degenerate with the TE<sub>011</sub> mode. Based on experience with fountain cavities, we intend to shift these modes 100-200 MHz or more while maintaining their  $Q$ 's at  $\sim 10,000$ . The additional drive power into the cavities required by off-resonant operation of the TE mode will certainly drive these modes harder, but the phase difference between TE and TM modes is correspondingly reduced, so the impact is quite small. Thus, when cavities are driven on resonance, the phase between the TE and TM modes is nearly  $\pi/2$  since the TM modes are far off resonance. With the TE mode driven off resonance, this phase angle difference becomes  $\sim 0.05$  radians, so the contribution of the TM modes to the distributed cavity phase shift is only three times worse than for on resonance cavities. Once again, this is not viewed as a problem.

## VIII. MODELED THERMAL STABILITY OF PARCS

Operating the cavities off resonance reduces the temperature coefficient of the end-to-end phase shift, but tight temperature regulation is still required to meet our requirements. Preliminary thermal models of the PARCS microwave interrogation region show a thermal time constant of approximately 30,000 seconds, which is to be compared to the 5000 second ISS orbital period. In the model, sudden changes in the thermal base-plate temperature of 5 K resulted in changes in temperature of approximately 20 mK using a thermostatic temperature controller. The use of a proportional temperature controller and estimates of the time rate of change of the base plate suggest that temperature variations over one day will be only a few mK. Such stability is aided by the absence of

convection and the weak coupling of the physics package to the external environment. Taking 3 mK to be the variation of temperature between cavity 1 and cavity 2, and assuming the cavities are detuned 10 half line widths, variations in the end-to-end phase over a single day would be expected to be 30 microradians, corresponding to a shift of  $2 \times 10^{-16}$ . This is comparable to our one-day stability, from which we conclude that measuring the end-to-end phase shift once per day will be sufficient under the assumptions outlined here.

## IX. CONCLUSION

We have described a conceptual design of the microwave interrogation structure for the PARCS cesium frequency standard and shown that it meets our requirements on end-to-end phase shift subject to daily evaluation of this offset. Critical to the design is the operation of the TE<sub>011</sub> cavities off of resonance.

## ACKNOWLEDGMENT

Thermal modeling of the PARCS cesium physics package was done by James Stultz of the Jet Propulsion Laboratory, California Institute of Technology.

A detailed design of the cavities and coupling structure has recently been completed by John Dick, Dan Hoppe, and Behrouz Khayatian of the Jet Propulsion Laboratory, California Institute of Technology.

## REFERENCES

- [1] S. R. Jefferts, *et al.*, "PARCS: a Primary Atomic Reference Clock in Space," Proc. 1999 Joint Meet. Eur. Freq. Time Forum and the IEEE Int. Freq. Contr. Symp., Besancon, France, pp. 141-144, Apr. 1999.
- [2] *e.g.* A. Bauch, *et al.*, "Recent Results of Physikalisch-Technische Bundesanstalt's Primary Clock CS1," *IEEE Trans. on Ultra., Ferr., and Freq. Con.*, 47, p. 443 (2000); W. D. Lee *et al.*, "The Accuracy Evaluation of NIST-7," *IEEE Trans on Inst. and Meas.* 44, p. 120 (1994).
- [3] W. M. Klipstein, *et al.*, "Phase Modulation with Independent Cavity-Phase Control in Laser Cooled Clocks in Space," Proc. 2001 IEEE Int. Freq. Contr. Symp., pp. 25-32 (2001).