



---

H A N D B O O K   O F

# Measuring System

D E S I G N

---

EDITORS   PETER H. SYDENHAM   RICHARD THORN

ARTICLE  
OFFPRINT

# 199: Characteristics of Time and Frequency Measurement

**Michael A. Lombardi**

National Institute of Standards and Technology, Boulder, CO, USA

---

1 Definition of Time, Time Interval, and Frequency	1341
2 Coordinated Universal Time (UTC)	1342
3 Measurement Terminology	1342
4 Measurement Techniques	1342
5 Oscillators and Clocks	1344
Acknowledgment	1345
Related Articles	1345
References	1345
Further Reading	1345

---

## 1 DEFINITION OF TIME, TIME INTERVAL, AND FREQUENCY

Time and frequency metrologists measure three basic quantities: time of day, time interval, and frequency. Time of day is usually provided in units of years, months, days, hours, minutes, and seconds. Devices that display or record time of day are called *clocks*. Synchronization is the process of setting multiple clocks to the same time.

Time interval is the duration or elapsed time between two events. The standard unit of time interval is the *second* (s). However, many applications require measuring shorter time intervals, such as *milliseconds* ( $1 \text{ ms} = 10^{-3} \text{ s}$ ), *microseconds* ( $1 \mu\text{s} = 10^{-6} \text{ s}$ ), *nanoseconds* ( $1 \text{ ns} = 10^{-9} \text{ s}$ ), and *picoseconds* ( $1 \text{ ps} = 10^{-12} \text{ s}$ ). The second is one of seven base units in the International System of Units (SI). The second was once defined on the basis of the earth's rotational

rate or as a fraction of the tropical year. That changed in 1967 when the era of atomic time keeping formally began. The second is now defined as follows:

The duration of 9 192 631 770 periods of the radiation corresponding to the transition between two hyperfine levels of the ground state of the cesium-133 atom.

Frequency is the rate of occurrence of a repetitive event. If  $T$  is the period of a repetitive event, then the frequency  $f$  is the period's reciprocal,  $1/T$ . Conversely, the period is the reciprocal of the frequency,  $T = 1/f$ . Since the period is a time interval expressed in seconds (s), the close relationship between time interval and frequency is easy to see. The standard unit for frequency is the *hertz* (Hz), defined as events or cycles per second. The frequency of electrical signals is often expressed in multiples of hertz, including *kilohertz* ( $1 \text{ kHz} = 10^3 \text{ Hz}$ ), *megahertz* ( $1 \text{ MHz} = 10^6 \text{ Hz}$ ), or *gigahertz* ( $1 \text{ GHz} = 10^9 \text{ Hz}$ ). A device that produces frequency is called an *oscillator*. *Syntony* is the process of setting multiple oscillators to the same frequency.

The three time and frequency quantities are closely related. As mentioned, the standard unit of time interval is the second. Seconds are counted to establish date and time of day. Events or cycles per second are counted to measure frequency and time interval. Time interval and frequency are measured with far less uncertainty and more resolution than any other physical quantities. Today (2002), the best time and frequency standards realize the SI second with uncertainties near  $1 \times 10^{-15}$ .

## 2 COORDINATED UNIVERSAL TIME (UTC)

The world's major metrology laboratories routinely send their measurement data to the Bureau International des Poids et Mesures (BIPM) in Sevres, France. The BIPM averages data collected from more than 200 atomic time and frequency standards located at more than 40 laboratories. The BIPM uses the data to generate Coordinated Universal Time (UTC), a timescale that realizes the SI second as closely as possible. The BIPM maintains UTC as a 'paper' timescale. National metrology laboratories use data published by the BIPM to steer their clocks and oscillators, and to generate and distribute real-time versions of UTC.

When necessary, leap seconds are added to UTC on either June 30 or December 31. Leap seconds keep atomic time (UTC) within  $\pm 0.9$  s of an older timescale called UT1, which is based on the Earth's rotation frequency. Leap seconds have been added to UTC at a rate of less than once per year since 1972.

UTC is the ultimate standard for time of day, time interval, and frequency. Clocks synchronized to UTC display the same hour, minute, and second all over the world (and remain within one second of UT1). Oscillators synchronized to UTC generate signals that serve as time interval and frequency standards.

## 3 MEASUREMENT TERMINOLOGY

The oscillator or clock being measured is called the *device under test* (DUT). A measurement compares the DUT to a standard or reference. The test signal for time measurements is usually a pulse that occurs once per second. Pulse width and polarity varies, but amplitude is often at TTL levels. The test signal for frequency measurements is usually a sine or a square wave that produces one cycle ( $360^\circ$  or  $2\pi$  radians of phase) in one period. The signal amplitude is expressed in volts (Figure 1).

Measurement results are stated in terms of accuracy and stability. Accuracy relates to the offset from an ideal

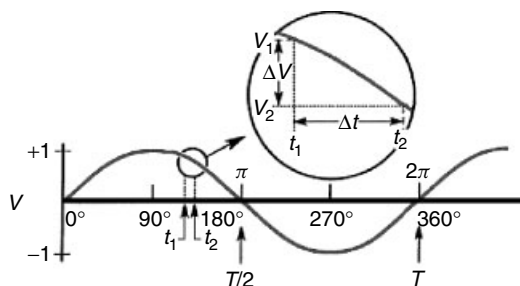

Figure 1. Oscillating sine wave.

value – see Article 54, Explanation of Key Error and Uncertainty Concepts and Terms, Volume 1. For example, time offset is the time interval between a measured on-time pulse and an ideal on-time pulse that coincides with the UTC second. Frequency offset is the difference between a measured frequency and an ideal frequency with zero uncertainty. This ideal frequency is called the *nominal frequency*.

Stability indicates how well a device produces the same time or frequency offset over a given time interval. It does not indicate whether the time or frequency is 'right' or 'wrong', but only whether it *stays the same*. Accuracy depends upon how well a device has been synchronized or syntonized, whereas stability is an inherent device characteristic.

Stability estimates are calculated from a set of either frequency offset or time offset measurements, and show time or frequency fluctuations with respect to a mean offset. The offset values are obtained by sampling or averaging over a stated interval, called tau ( $\tau$ ). Short-term stability refers to fluctuations over short intervals (often where  $\tau = 1$  s, or at least where  $\tau$  is less than 100 s). Long-term stability can refer to any  $\tau$  value greater than 100 s, but usually refers to values longer than 1 day. An oscillator specification sheet usually lists stability estimates at  $\tau$  values increasing in length until the point, called the *noise floor*, where the stability stops improving. The most common statistics used to estimate stability are the Allan deviation ( $\sigma_y(\tau)$ ) for frequency stability, and the Time deviation ( $\sigma_x(\tau)$ ) for time stability. Further information on the uncertainty of measurements is found in Article 55, Uncertainty Determination, Volume 1.

## 4 MEASUREMENT TECHNIQUES

If a single time interval or frequency measurement is made, the uncertainty is often limited by measurement system noise, or a lack of resolution. Averaging measurements usually leads to more resolution and lowers the measurement system's noise floor. To obtain a correct result, the measurement interval must be long enough to ensure that both the measurement system and reference have lower noise floors than the DUT.

Time interval is usually measured with a time interval counter (TIC). A TIC requires two signal inputs. One signal starts the counter and the other stops it, and the TIC measures the interval between the signals. The best TICs have a single shot resolution near 20 ps, which sometimes averages down to near 1 ps.

Simple frequency measurements are made with a frequency counter (Figure 2). The measurement reference

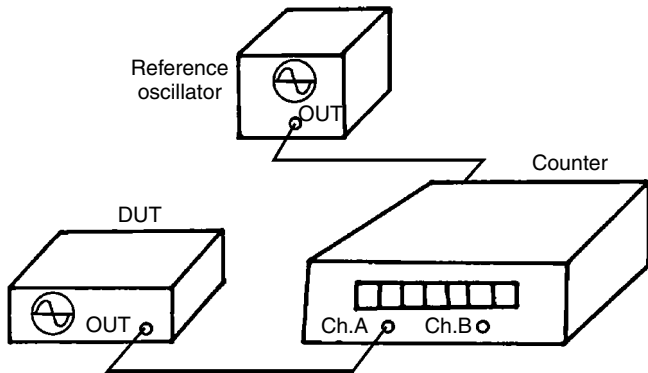

Figure 2. Frequency measurement with frequency counter.

is the counter's time base oscillator. Frequency offset (dimensionless) is determined as

$$f(\text{offset}) = \frac{f_{\text{measured}} - f_{\text{nominal}}}{f_{\text{nominal}}} \quad (1)$$

where  $f_{\text{measured}}$  is the reading displayed by the frequency counter, and  $f_{\text{nominal}}$  is the frequency labeled on the oscillator (the nominal frequency it is supposed to produce).

More advanced frequency measurements are phase comparisons between the DUT and reference signals. The concept of a phase comparison is best illustrated on an oscilloscope where the waveforms are visible (Figure 3), but higher resolution comparisons are made with a TIC, using the DUT to start the counter, and the reference to stop the counter. The time interval change is used to estimate the frequency offset:

$$f(\text{offset}) = \frac{-\Delta t}{T} \quad (2)$$

where  $\Delta t$  is the change in time interval, and  $T$  is the measurement period. This requires only two time interval readings, and  $\Delta t$  is simply the difference between the two readings. Typically, multiple readings are taken, least squares linear regression is applied to the data set, and  $\Delta t$  is obtained from the slope of the least squares line. If desired, the dimensionless frequency offset can be multiplied by the nominal frequency and converted to hertz.

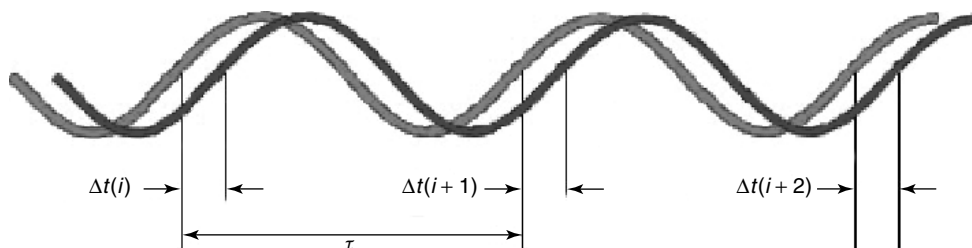

Figure 3. Phase comparison between two sine waves.

Since standard test frequencies have short periods (100 ns in the case of 10 MHz), keeping track of cycles during a phase comparison is difficult. Therefore, phase comparisons normally test low frequencies with long periods, such as 1 or 10 Hz. The low frequency is obtained by dividing the test frequency, or by mixing it with another frequency to generate a beat frequency.

Divider systems (Figure 4) are more versatile, and can be built or programmed to work with nearly any test frequency. They can convert any test frequency to 1 Hz, for example, by simply removing  $n - 1$  cycles of the test frequency. In this fashion, a 5-MHz signal can be divided and compared to a 1-Hz signal. Divider systems normally cannot detect frequency changes smaller than parts in  $10^{11}$  in 1 s, since the single shot resolution and short-term stability of a TIC/Divider system is limited to tens of picoseconds.

Mixer systems (Figure 5) are less versatile and more complex. They are often designed for a single test frequency, they cannot measure 1-Hz timing signals or similar low frequencies, and they usually require the DUT and reference to have the same nominal frequency. The dual mixer time difference measurement system shown in the figure mixes the DUT and reference signals with a signal from a transfer oscillator offset from the nominal frequency. If the nominal frequency is 10 MHz, and the offset frequency is 10.000010 MHz, the result is 2 beat frequencies near 10 Hz that are compared using a TIC. The ratio of the nominal frequency to the beat frequency is the heterodyne factor ( $10^7/10 = 10^6$  in this example). The system's resolution is the period of the TIC's time base oscillator divided by the heterodyne factor. For example, if the TIC

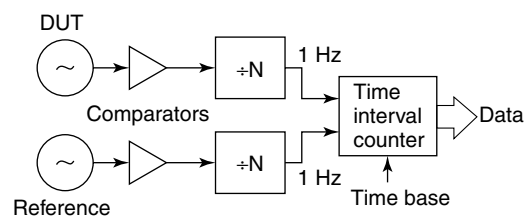

Figure 4. Time interval counter measurement system with frequency dividers.

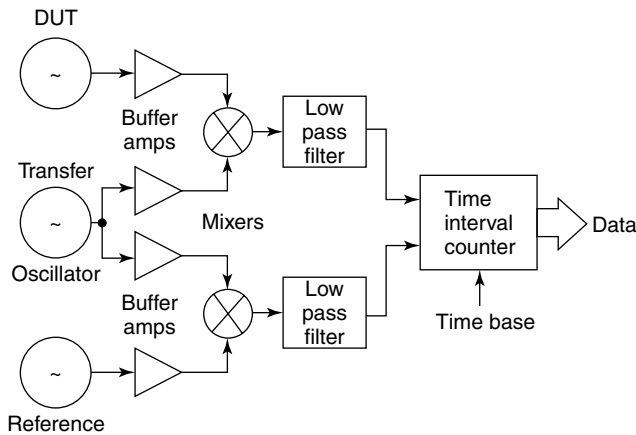

Figure 5. Dual mixer time difference measurement system.

has a 10-MHz time base, the resolution equals  $100 \text{ ns}/10^6$  or 0.1 ps. This high resolution makes it possible to detect frequency changes of parts in  $10^{13}$  in 1 s, and makes a dual mixer system well suited for measuring short-term stability. However, divider and mixer systems should produce the same answer when measuring long-term stability, since the noise floor of both systems eventually drops below the DUT noise floor.

## 5 OSCILLATORS AND CLOCKS

Oscillators consist of a resonator that produces a periodic event, and an energy source that sustains oscillation. The natural frequency of an oscillator is called the *resonance frequency*. A clock is a device that counts oscillator cycles and displays or records time. For example, a quartz wrist-watch contains an oscillator that runs at 32 768 Hz. After

counting 32 768 cycles, the watch circuitry records that one second has elapsed. Seconds are counted to establish longer time intervals such as minutes, hours, and days.

The Q of an oscillator is its resonance frequency divided by its resonance width, or the range of possible frequencies at which the oscillator can oscillate. High-Q resonators generally lead to more stable oscillators, since they will not resonate at all unless they are operated near their resonance frequency.

Quartz oscillators achieve the highest Q of any mechanical-type oscillators, but atomic oscillators have much higher Q factors. In theory, the atom is a perfect resonator. Atomic oscillators use the quantized energy levels in atoms and molecules as their resonance source. An electromagnetic field at a particular frequency boosts an atom from one energy level to a higher one. Conversely, an atom at a high energy level can drop to a lower level by emitting energy. The resonance frequency ( $f$ ) of an atomic oscillator is the difference between the two energy levels divided by Planck’s constant ( $h$ ):

$$f = \frac{E_2 - E_1}{h} \tag{3}$$

Table 1 provides a summary of oscillators used as time and frequency standards.

### 5.1 Quartz oscillators

Quartz oscillators use a quartz crystal as a resonator. The crystal strains (expands or contracts) when a voltage is applied. When the voltage reverses, the strain reverses. This is known as the *piezoelectric effect*. The rate of expansion and contraction is the resonance frequency, and

Table 1. Summary of oscillator types.

Oscillator type	Quartz (TCXO)	Quartz (OCXO)	Rubidium	Commercial cesium beam	Hydrogen maser
Q	$10^4 - 10^6$	$3.2 \times 10^6$ (5 MHz)	$10^7$	$10^8$	$10^9$
Resonance Frequency	Various	Various	6.834682608 GHz	9.192631770 GHz	1.420405752 GHz
Leading cause of failure	None	None	Rubidium lamp (life expectancy > 15 years)	Cesium beam tube (life expectancy of 3 to 25 years)	Hydrogen depletion (life expectancy > 7 years)
Stability, $\sigma_y(\tau), \tau = 1 \text{ s}$	$1 \times 10^{-8}$ to $1 \times 10^{-9}$	$1 \times 10^{-12}$	$5 \times 10^{-11}$ to $5 \times 10^{-12}$	$5 \times 10^{-11}$ to $5 \times 10^{-12}$	$1 \times 10^{-12}$
Noise floor, $\sigma_y(\tau)$	$1 \times 10^{-9}$ ( $\tau = 1$ to $10^2 \text{ s}$ )	$1 \times 10^{-12}$ ( $\tau = 1$ to $10^2 \text{ s}$ )	$1 \times 10^{-12}$ ( $\tau = 10^3 - 10^5 \text{ s}$ )	$1 \times 10^{-14}$ ( $\tau = 10^5 - 10^7 \text{ s}$ )	$1 \times 10^{-15}$ ( $\tau = 10^3 - 10^5 \text{ s}$ )
Aging/year	$5 \times 10^{-7}$	$5 \times 10^{-9}$	$1 \times 10^{-10}$	None	$\sim 1 \times 10^{-13}$
Frequency Offset after warm up	$1 \times 10^{-6}$	$1 \times 10^{-8}$ to $1 \times 10^{-10}$	$5 \times 10^{-10}$ to $5 \times 10^{-12}$	$5 \times 10^{-12}$ to $1 \times 10^{-14}$	$1 \times 10^{-12}$ to $1 \times 10^{-13}$
Warm-up period	<10 s to $1 \times 10^{-6}$	<5 min to $1 \times 10^{-8}$	<5 min to $5 \times 10^{-10}$	30 min to $5 \times 10^{-12}$	24 h to $1 \times 10^{-12}$

is determined by the crystal's size and shape. Q factors for quartz oscillators range from  $10^4$  to  $10^6$ .

Quartz oscillators are sensitive to changes in temperature, humidity, pressure, and vibration, but several designs reduce these environmental effects. The oven-controlled crystal oscillator (OCXO) encloses the crystal within a temperature-controlled chamber. The temperature-compensated crystal oscillator (TCXO) generates frequency changes equal and opposite to frequency changes produced by temperature. TCXOs are less expensive, but less stable than OCXOs.

Quartz oscillators have excellent short-term stability but poor long-term stability. An OCXO might be stable ( $\sigma_y(\tau)$ , at  $\tau = 1$  s) to  $1 \times 10^{-12}$ . Long-term stability is limited by aging, or a frequency change with time caused by internal oscillator changes. The aging rate of a high quality OCXO might be parts in  $10^9$  per year, while a TCXO might age 100 times faster. Since quartz oscillators change frequency substantially over time, atomic oscillators are needed for applications requiring long-term stability.

## 5.2 Atomic oscillators

Rubidium oscillators are the lowest priced atomic oscillators. They operate at 6 834 682 608 Hz, the resonance frequency of the rubidium atom ( $^{87}\text{Rb}$ ), and use the rubidium frequency to control the frequency of a quartz oscillator. The Q of a rubidium oscillator is about  $10^7$ . Stability ( $\sigma_y(\tau)$ , at  $\tau = 1$  s) is typically  $1 \times 10^{-11}$ , and about  $1 \times 10^{-12}$  at one day. Frequency offset ranges from  $5 \times 10^{-10}$  to  $5 \times 10^{-12}$  after a warm-up period of a few minutes or hours, so they meet the accuracy and stability requirements of most applications without adjustment.

Cesium oscillators physically realize the SI second, since the second is defined on the basis of the resonance frequency of the cesium atom ( $^{133}\text{Cs}$ ), which is 9 192 631 770 Hz. A cesium oscillator should stay close to its nominal frequency without adjustment, and there should be no frequency change due to aging. The Q of a commercial cesium standard is a few parts in  $10^8$ . Stability ( $\sigma_y(\tau)$ , at  $\tau = 1$  s) is typically  $5 \times 10^{-12}$ , and reaches a

noise floor near  $1 \times 10^{-14}$  in about one day, extending to weeks or months. The frequency offset is typically less than  $1 \times 10^{-12}$  after a 30-min warm up.

## ACKNOWLEDGMENT

Contribution of United States Government, not subject to copyright.

## RELATED ARTICLES

**Article 54, Explanation of Key Error and Uncertainty Concepts and Terms, Volume 1; Article 55, Uncertainty Determination, Volume 1; Article 200, Calibrations and Standards in Time Measurement, Volume 3.**

## REFERENCES

- Agilent Technologies (2003a) *Fundamentals of Time Interval Measurement*, Agilent Application Note 200-3 (p. 68), URL: <http://cp.literature.agilent.com/litweb/pdf/5965-7663E.pdf>.
- Agilent Technologies (2003b) *Fundamentals of the Electronic Counters*, Agilent Application Note 200 (p. 44), URL: <http://cp.literature.agilent.com/litweb/pdf/5965-7660E.pdf>.
- Carr, J.J. (1996) *Elements of Electronic Instrumentation and Measurement*, Prentice Hall, NJ.
- Kamas, G. and Lombardi, M.A. (1990) *Time and Frequency User's Manual*, National Institute of Standards, Special Publ. 559 (p. 160), URL: <http://tf.nist.gov/general/pdf/461.pdf>.
- Sullivan, D.B., Allan, D.W., Howe, D.A. and Walls, F.L. (eds) (1990) *Characterization of Clocks and Oscillators*, National Institute of Standards, Technol. Tech Note 1337 (p. 352), URL: <http://tf.nist.gov/general/pdf/868.pdf>.
- Webster, J.G. (1999) *The Measurement, Instrumentation, and Sensors Handbook*, CRC Press, Boca Raton, FL.

## FURTHER READING