



H A N D B O O K O F

Measuring System

D E S I G N

EDITORS PETER H. SYDENHAM RICHARD THORN

ARTICLE
OFFPRINT

200: Calibrations and Standards in Time Measurement

Michael A. Lombardi

National Institute of Standards and Technology, Boulder, CO, USA

1 Time Standards	1346
2 Calibration of Short Time Interval Sensors	1346
3 Calibration of Medium and Long Time Interval Sensors	1348
4 Time Synchronization	1349
Acknowledgments	1349
Related Articles	1349
References	1349
Further Reading	1350

1 TIME STANDARDS

Time measurements include time interval measurements, which determine the elapsed time between two events; and time synchronization measurements, which determine the time offset between the test signal and the Coordinated Universal Time (UTC) second. Time standards typically produce 1 pulse per second (pps) signals. The period of these signals is a standard second that serves as a time interval reference. If the 1-pps signal is 'on time', or synchronized to UTC, it can also serve as a time synchronization reference. If the 1-pps signal is labeled, or time tagged, it can be used to synchronize time-of-day clocks. Some devices produce time tags at frequencies higher than 1 pps, with resolutions measured in milliseconds (ms), in microseconds (μ s), or in nanoseconds (ns).

The second is defined as 'The duration of 9 192 631 770 periods of the radiation corresponding to the transition between two hyperfine levels of the ground state of the

cesium-133 atom.' This definition was added to the International System (SI) of units in 1967, and therefore the 1-pps output from a cesium oscillator serves as an internationally recognized time interval standard. Commercially available cesium standards (Figure 1 provides a block diagram) routinely replicate the SI second with uncertainties near 1×10^{-13} . Even so, it is interesting to note that the 1-pps output from a cesium oscillator is not on time unless it has been synchronized. Prior to synchronization, the cesium timing pulse could be fast or slow by as much as 0.5 s with respect to UTC.

Cesium oscillators are expensive, and can cost \$50 000 (USD) or more. They are usually owned only by facilities with stringent measurement uncertainty requirements. A more commonly owned time standard is a disciplined oscillator that receives radio broadcasts containing UTC information. The received information is often used to discipline a local quartz or rubidium oscillator, display the time-of-day, and to synchronize a 1-pps signal to agree with UTC. By applying continuous time and frequency corrections to the local oscillator signal, often through the use of a phase-locked loop, these radio-controlled devices can sometimes meet or exceed cesium oscillator performance over averaging periods of more than 1 day.

2 CALIBRATION OF SHORT TIME INTERVAL SENSORS

Measurements of time intervals less than 1 s are often made with oscilloscopes. Since oscilloscopes allow us to view the pulse waveforms, it is possible to select the

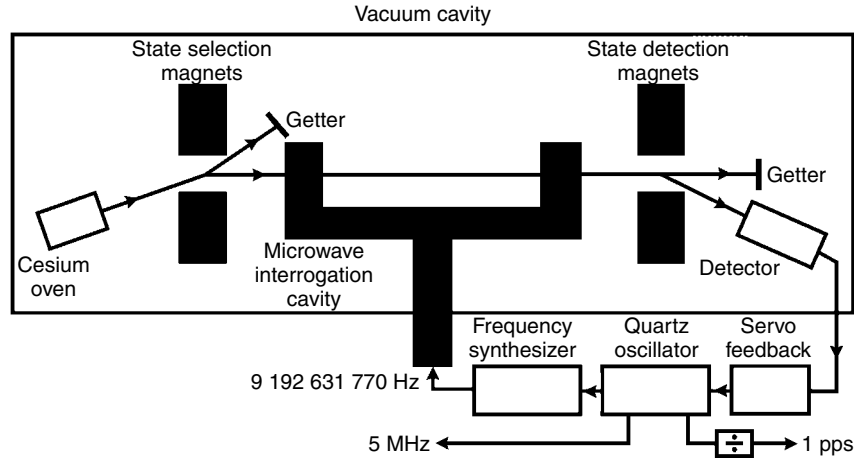

Figure 1. Block diagram of cesium oscillator.

precise start and end points that define a time interval, a major advantage when dealing with odd-shaped or noisy waveforms. Sometimes one pulse is displayed, while a different pulse is used to trigger the oscilloscope. Another method is to display both time pulses on a dual-trace oscilloscope. Triggering can be achieved from either of the two displayed pulses or from a third external pulse. The oscilloscope displayed in Figure 2 is triggering from channel A, and shows a 4- μ s time interval between the A and B pulses.

The disadvantage of oscilloscopes for time interval measurements is lack of resolution and range. Oscilloscope range varies, and some models might be able to scale from 50 ps to 10 s per time division. However, the resolution

of the time interval measurement is proportional to the length of the interval. If the time pulses are 10 ms apart, for instance, the best oscilloscopes can only resolve the interval to about $\pm 1 \mu$ s. However, if the pulses are only 100 μ s apart, the resolution is ± 10 ns. In both cases, the relative uncertainty is 1×10^{-4} .

Time interval counters (TIC) are better suited for measuring all but the shortest time intervals. A start pulse gates the TIC (starts it counting) and a stop pulse stops the counting. While the gate is open (Figure 3), the counter counts zero crossings from time base oscillator cycle, and the resolution of the simplest TICs is equivalent to the period of a time base cycle (for example, 100 ns for a 10 MHz time base). However, many TICs use interpolation schemes to slice the cycle period into smaller parts. For example, slicing the 100-ns period into 5000 parts allows 20-ps resolution, a feat achieved by the best units. This translates to measurement uncertainties of a few parts in 10^{11} over a 1-s interval, often averaging down to parts in 10^{15} or 10^{16} after a few hours. Since these uncertainties are so low, TICs are routinely used for long-term comparisons between cesium oscillators.

The uncertainty of TIC measurements is, however, potentially limited by count ambiguity, trigger errors, or time base errors. A TIC generally has a +1 count or -1 count ambiguity in the least significant digit of its display. However, this ± 1 count error usually averages out when multiple readings are taken, and is usually a problem only with single-shot measurements. Trigger errors are a more significant problem. They occur when the counter does not trigger at the expected voltage level on the input signal. Trigger errors can be caused by incorrectly set trigger levels or by input signals that are noisy (Figure 4), too large, or too small. Figure 4 illustrates that while triggering is desired on point a, noisy signals can cause triggering on points b or

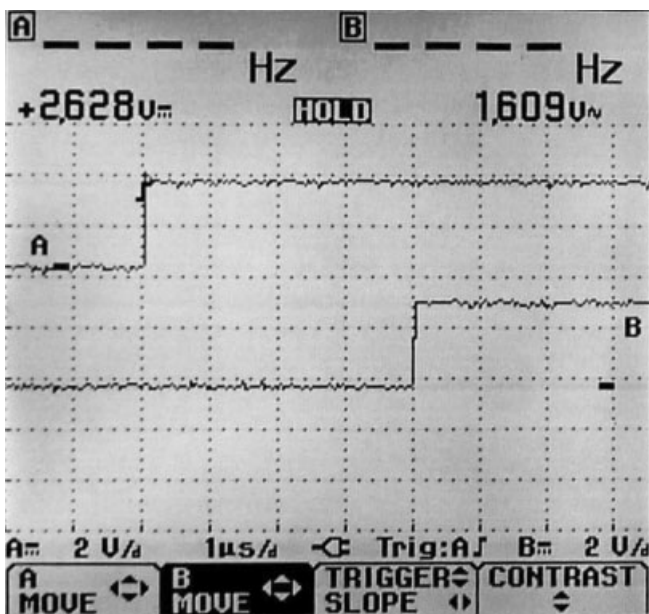

Figure 2. Measuring time interval with an oscilloscope.

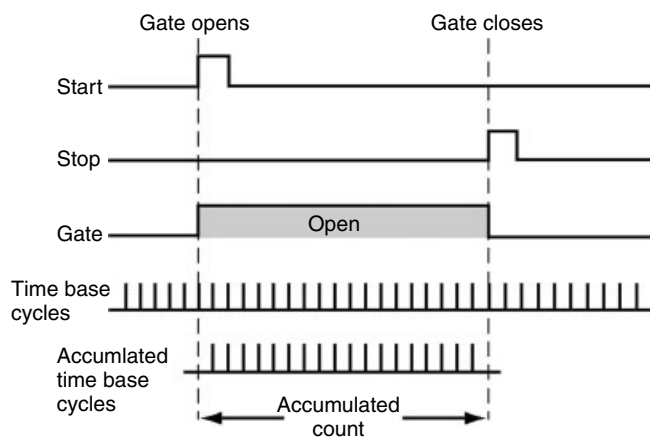

Figure 3. Gate and counting function of time interval counter.

c. This leads to incorrect measurements, so make sure the TIC is triggering at the proper point on both the start and stop waveforms (if necessary, view the waveforms on an oscilloscope). Time base errors are generally not a problem when measuring short time intervals. For example, consider a typical counter with 1-ns resolution and a time base stability of 1×10^{-8} . When a 1-ms interval is measured, the time base uncertainty is $10^{-3} \text{ s}/10^8 = 10^{-11} \text{ s}$, or 10 ps. This is 100 times smaller than the 1-ns uncertainty contributed by the ± 1 count ambiguity. Even so, use the most stable oscillator available as an external time base, because time base errors are significant when measuring long time intervals.

Application notes are available for more detail, Agilent Technologies (2003a, b).

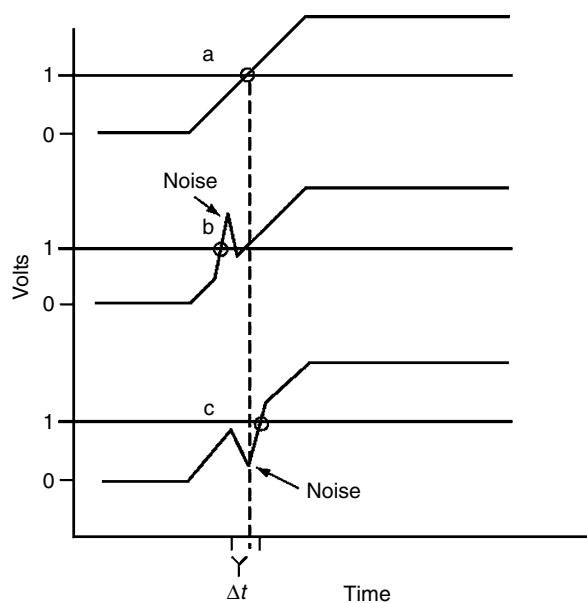

Figure 4. Potential effects of trigger errors on time interval measurements.

3 CALIBRATION OF MEDIUM AND LONG TIME INTERVAL SENSORS

A TIC is probably the best device for medium and long time interval measurements if it has the necessary range. For example, a TIC that counts 100 ns periods with a 32-bit counter will overflow after $2^{32} \times 100 \text{ ns}$, or about 429 s. However, many TICs keep track of counter overflows, and some have the ability to measure intervals of about 1 day in time interval mode. If the TIC range is insufficient, most universal counters have a totalize mode that simply counts cycles from an external frequency source. Some commercial counters can count up to 10^{15} cycles. The period of the external gate frequency determines the resolution of this type of measurement. For example, if 1- μs resolution is desired, use a 1-MHz gate frequency. In this case, the time interval range would be $10^{15}/10^6 = 10^9 \text{ s}$, or nearly 32 years! In either time interval or totalize mode, a properly calibrated and triggered counter will probably exceed any measurement uncertainty requirements.

Low cost, simple timers are commonly used for coarse measurements of time intervals ranging from several seconds to many hours. These timers are typically found in manufacturing, industrial, medical, or laboratory facilities; or are sometimes used in commercial applications where consumers pay for services such as a ride in a taxicab or the use of a parking space. These timers are usually calibrated outside the laboratory, with field standard stopwatches. The stopwatches themselves require calibration, and this is often done by manually triggering the stopwatch while listening to an audio time signal. The legally required uncertainty for stopwatch calibrations is often 1 or 2 parts in 10^4 , a large uncertainty limited mostly by human reaction time.

Stopwatch calibration methods exist that reduce or eliminate the problem of human reaction time. One method is to use a universal counter in totalize mode. Gate the counter with a signal from a calibrated signal generator. The gate frequency should have a period at least one order of magnitude smaller than the resolution of the stopwatch. For example, if the stopwatch has 0.01-s resolution (10 ms), use a 1-kHz frequency (1-ms period). This provides the counter with one more digit of resolution than that of the stopwatch. Start and stop the totalize counter by rapidly pressing the start-stop button of the stopwatch against the start-stop button on the counter. Then, compare the two readings and use the equation $\Delta t/T$ to get the results, where Δt is the difference between the counter and stopwatch displays and T is the length of the measurement run. For example, if $\Delta t = 100 \text{ ms}$ and $T = 1 \text{ h}$, the time uncertainty is roughly 2.8×10^{-5} .

Table 1. Coordinated universal time (UTC) broadcast signals.

Station name or signal source	Nation responsible for signal	Coverage	Carrier frequency
JJY	Japan	Asian Pacific Rim	40 kHz 60 kHz
WWVB	United States	North America	60 kHz
MSF	United Kingdom	Europe	60 kHz
BPC	China	China	68.5 kHz
HBG	Switzerland	Europe	75 kHz
DCF77	Germany	Europe	77.5 kHz
WWV	United States	Worldwide ^a	2.5, 5, 10, 15, 20 MHz
WWVH	United States	Worldwide ^a	2.5, 5, 10, 15 MHz
CHU	Canada	Worldwide ^a	3.33, 7.335, 14.670 MHz
Indian National Satellite System (INSAT)	India	Indian subcontinent	2599.675 MHz
Global Navigation Satellite System (GLONASS)	Russia	Worldwide	1602.5625–1615 MHz (L1), 1240–1260 MHz (L2)
Global Positioning System (GPS)	United States	Worldwide	1575.41 MHz (L1) 1227.42 MHz (L2)

^aUnder optimal conditions.

A second method involves measuring the frequency offset of the stopwatch time base, and then converting the frequency offset to a time offset. Commercially available systems perform this measurement for both mechanical and electronic stopwatches (with 32.768 kHz or 4.19 MHz time bases). If an appropriate sensor is available (for example, an ultrasonic acoustic sensor for 32.768-kHz devices), this measurement can also be performed with a frequency counter. For example, if a 32.768-kHz time base has a 0.1-Hz frequency offset, the relative frequency offset ($0.1/32768 = 3 \times 10^{-5}$) translates to a time offset of about 108 ms in 1 h, or near the value for Δt in the previous example.

4 TIME SYNCHRONIZATION

Using the time interval measurement methods described above, a timing device can be synchronized by comparing it to a UTC reference, and by adjusting the time offset until it is as near zero as possible. Radio-controlled clocks are convenient UTC references. Models exist to receive signals scattered throughout the radio spectrum (Table 1), and they are commonly used for the synchronization of timing pulses and time-of-day clocks. The most common units receive low-frequency radio signals from stations such as WWVB (60 kHz) in the United States, MSF (60 kHz) in the United Kingdom, DCF77 (77.5 kHz) in Germany, or JJY (40 and 60 kHz) in Japan. The power levels from these broadcasts are large enough to cover their respective countries and a few neighboring countries, but no single broadcast is available internationally. The on-time pulse is delayed by the path between the transmitter and receiver,

and if uncorrected for path delay, the synchronization uncertainty is often measured in milliseconds.

Better performance and true worldwide coverage can be obtained using a Global Positioning System (GPS) satellite receiver. Most GPS receivers receive the L1 carrier frequency (1575.42 MHz) broadcast by an orbiting constellation of at least 24 satellites. The long-term performance of a GPS receiver often meets or exceeds that of a cesium oscillator (2×10^{-13} uncertainty is typical at 1 day), and the 1-pps timing pulse of a calibrated receiver is usually within 100 ns of UTC. A properly operated GPS timing receiver is an excellent choice as a laboratory standard for time interval and time synchronization measurements.

ACKNOWLEDGMENTS

Contribution of United States government, not subject to copyright.

RELATED ARTICLES

Article 54, Explanation of Key Error and Uncertainty Concepts and Terms, Volume 1; Article 55, Uncertainty Determination, Volume 1; Article 199, Characteristics of Time and Frequency Measurement, Volume 3.

REFERENCES

Agilent Technologies (2003a) *Fundamentals of Time Interval Measurement*, Agilent Application Note 200-3 (p. 68), URL: <http://cp.literature.agilent.com/litweb/pdf/5965-7663E.pdf>.

Agilent Technologies (2003b) *Fundamentals of the Electronic Counters*, Agilent Application Note 200 (p. 44), URL: <http://cp.literature.agilent.com/litweb/pdf/5965-7660E.pdf>.

FURTHER READING

Carr, J.J. (1996) *Elements of Electronic Instrumentation and Measurement*, Prentice Hall, NJ.

Gust, J.C., Graham R.M. and Lombardi, M.A. (2004) *Stop-watch and Timer Calibrations*, National Institute of Standards and Technology, Special Publ. 960-12 (p. 60), URL: <http://tf.nist.gov/general/pdf/1930.pdf>.

Kamas, G. and Lombardi, M.A. (1990) *Time and Frequency User's Manual*, National Institute of Standards and Technology.

Special Publ. 559 (p. 160), United States Government Printing Office, URL: <http://tf.nist.gov/general/pdf/461.pdf>.

Lombardi, M.A. (2002) *NIST Time and Frequency Services*, National Institute of Standards and Technology, Special Publ. 432 (p. 80), United States Government Printing Office, URL: <http://tf.nist.gov/general/pdf/1383.pdf>.

Lombardi, M.A., Nelson, L.M., Novick, A.N. and Zhang, V.S. (2001) Time and Frequency Measurements Using the Global Positioning System. *Cal Lab: The International Journal of Metrology*, **8**, 26–33, URL: <http://tf.nist.gov/general/pdf/1424.pdf>.

Zhang, V.S., Davis, D.D. and Lombardi, M.A. (1994) High Resolution Time Interval Counter, in *Proceedings of 26th Annual Precise Time and Time Interval (PTTI) Meeting* (pp. 191–200), (Reston, Virginia) URL: <http://tf.nist.gov/general/pdf/870.pdf>.